

SONY®

DVS-9000/9000SF System

(With CCP-8000 Series Center Control Panel)

User's Guide

Production Switcher System

Volume 1

English

1st Edition (Revised 1)

Software Version 2.00 and Later

NOTICE TO USERS

© 2002 Sony Corporation. All rights reserved. This manual or the software described herein, in whole or in part, may not be reproduced, translated or reduced to any machine readable form without prior written approval from Sony Corporation.

SONY CORPORATION PROVIDES NO WARRANTY WITH REGARD TO THIS MANUAL, THE SOFTWARE OR OTHER INFORMATION CONTAINED HEREIN AND HEREBY EXPRESSLY DISCLAIMS ANY IMPLIED WARRANTIES OF MERCHANTABILITY OR FITNESS FOR ANY PARTICULAR PURPOSE WITH REGARD TO THIS MANUAL, THE SOFTWARE OR SUCH OTHER INFORMATION. IN NO EVENT SHALL SONY CORPORATION BE LIABLE FOR ANY INCIDENTAL, CONSEQUENTIAL OR SPECIAL DAMAGES, WHETHER BASED ON TORT, CONTRACT, OR OTHERWISE, ARISING OUT OF OR IN CONNECTION WITH THIS MANUAL, THE SOFTWARE OR OTHER INFORMATION CONTAINED HEREIN OR THE USE THEREOF.

Sony Corporation reserves the right to make any modification to this manual or the information contained herein at any time without notice.

The software described herein may also be governed by the terms of a separate user license agreement.

Functions Newly Supported in Version 2.00

The functions newly supported in the DVS-9000/9000SF system version 2.00 ¹⁾ are as follows.

1) For the BKDS-9470: version 1.40

Functions relating to switcher processor

Classification	Functions supported	Menu No.	See page	
			Vol. 1	Vol. 2
Frame memory	Frame memory feed using key processed keyer signals	1115	285 297	–
	Changes in Frame Memory menu	2111 to 2144	348	–
Copy and swap	Color data copy and swap relating to DME	3116	81	–
Misc menu	Enabling/disabling control from external devices	3211	376	–
Setup	User region setting	7331.4	152	238
	Logical assignment of PGM/PST to M/E	7331.5	152	238
	Through mode for program output/clean output	7333.3	153	242
	Preset color mix operation mode	7334.1	40, 153	245
	Selection of mask and border process priority	7335	153	248
	9-pin port device interface setting	7337.1	154	253
	KF Reverse Run (GPI input operation)	7337.2	–	255
	Enabling/disabling AUX bus control	7337.5	154	258

Functions relating to DME

Classification	Functions supported	Menu No.	See page	
			Vol. 1	Vol. 2
Three-dimensional transform	Three-dimensional parameter display	4100 and each DME menu	97	17
Special effects	Multi move	4122	99	31
	Freeze	4131	100	36

Functions relating to external devices

Classification	Functions supported	Menu No.	See page	
			Vol. 1	Vol. 2
External device control	GPI device control	5311	120	91
	VTR/disk recorder control	5331 to 5333	121	94

Functions relating to keyframe effects

Classification	Functions supported	Menu No.	See page	
			Vol. 1	Vol. 2
Keyframe creation and execution ^{a)}	Keyframe loop	–	129	128
	Attributes (effect dissolve)	6221	128	150
Master timeline	Master timeline creation and saving	6211 to 6217	139	145
Menu operations	Simultaneous operations in multiple regions	6221 to 6227	–	170

a) Not supported by DME.

Functions relating to snapshots

Classification	Functions supported	Menu No.	See page	
			Vol. 1	Vol. 2
Master snapshot	Master snapshot creation and saving	6311 to 6317	140	174
Menu operations	Simultaneous operations in multiple regions	6321 to 6357	–	170

Functions relating to utility/shotbox

Classification	Functions supported	Menu No.	See page	
			Vol. 1	Vol. 2
Utility	Utility function execution	–	143	178
Shotbox	Shotbox register creation from the numeric keypad control block	–	–	181
Menu operations	Simultaneous shotbox register creation in multiple regions	6411.1	–	183

Functions relating to setup

Classification	Functions supported	Menu No.	See page		
			Vol. 1	Vol. 2	
System	Master panel for tally control	7312.1	–	197	
	Key bus delegation button control setting (initial status setting)	7314	–	200	
Control panels Config	Link settings relating internal switcher buses to routing switcher destinations	7321.3	149	207	
	Reference module selection for the device control block	7321	149	210	
	Region selection button assignment for the numeric keypad control block	7321.7	149	210	
	Program button assignment setting	7321.8	149	211	
	Xpt Assign	Source name and destination name export	7322.5	150	216
	Prefs/Utility	Button assignment setting	7324	150	218
	Device Interface	Additional actions for GPI input ^{a)}	7325.1	–	223
		DCU serial port setting	7325.4	150	226
	Operation	Setup relating to effects <ul style="list-style-type: none"> • Automatic turning off of [EDIT ENBL] • Automatic insertion of the first keyframe • Keyframe duration default value • Setting whether to replay the first keyframe after rewinding (GPI/P-BUS/DDR/VTR) 	7326.2/5/6	150	228
		Button operation mode setting <ul style="list-style-type: none"> • for during auto transition • for during keyframe execution 	7326.4	151	230
		Trackball, joystick and double-click sensitivity adjustment	7326.5	151	232
	Maintenance	Touch panel calibration	7327	151	233
	DCU	Additional actions for GPI input ^{a)}	7352	–	267
Serial port setting		7355	155	273	
Router interface and tally	Serial tally setting	7367	156	288	

a) FM1/2 Frame Freeze, FM1/2 Field Freeze, FM1/2 Freeze Off

Functions relating to files

Classification	Functions supported	Menu No.	See page	
			Vol. 1	Vol. 2
Menu operations	Changes in File menu operations <ul style="list-style-type: none"> operations between files Individual frame memory file operations 	7111 to 7171	158	294
File import and export	Image data import and export for frame memory	7161	159	304
Directories	Directory operations	7171	–	306

Functions relating to macros

Classification	Functions supported	Menu No.	See page	
			Vol. 1	Vol. 2
Macros	Macro function	5421	160	309

Principal Changes From Version 1.30

The principal changes from version 1.30 are as follows.

Classification	Functions changed		See page	
			Vol. 1	Vol. 2
[DEST] button in the auxiliary bus control block	Before change	<u>While this button is held down</u> , the names of buses allocated to the delegation buttons appear in the selection source name displays.	195	–
	After change	<u>Press this button</u> , turning it on, to display the names of buses allocated to the delegation buttons in the selection source name displays.		

Functions Not Supported in Version 2.00

The following functions are not supported in the DVS-9000/9000SF system version 2.00.

Classification	Functions not supported	Menu No.	See page	
			Vol. 1	Vol. 2
DME wipe	Additional patterns: <ul style="list-style-type: none"> • Frame in-out (No. 1201 to 1204) • Picture-in-picture (No. 1251, 2651, 2652) 	1161/1162	69	338 340
	Size and crop adjustment	1165	337	–
	Individual modifier adjustment for two-channel mode patterns	1164, 1165	333	–
	User programmable DME transition mode setting	6114	342	132
DME special effects	Beveled edge	4112	99	27
	Defocusing of video signal only	4121	98	29
	Stardust trail afterimages	4152	110	69
	Motion decay	4153	110	70
	Keyframe strobe	4154	110	71
	Key density	4162	112	75
	Key source selection	4162	112	76
DME setup	KF Reverse Run (GPI input operation)	7344.1/4	–	262
Macros	Macro operations in the numeric keypad control block	–	160	310
	Event creation <ul style="list-style-type: none"> • Effect recall • Snapshot recall • Keyframe rewind and run 	–	160	312

Table of Contents

Chapter 1 DVS-9000 Functions

Introduction	20
Features of the DVS-9000 Production Switcher System.....	22
Video Processing Flow	24
Signal Selection	25
Basics of Signal Selection	26
Bus Selection	26
Signal Assignment and Selection	28
Signal Name Display	31
Transitions.....	32
Selecting the Next Transition	32
Independent Key Transitions.....	35
Transition Types.....	39
Executing a Transition.....	42
Keys.....	46
Key Types.....	46
Key Modifiers.....	50
Key Memory.....	54
Key Snapshots	54
Blink	54
Key Default	55
Key Modify Clear.....	55
Wipes	56
Types of Wipe Pattern	56
Pattern Mix	57
Wipe Pattern Variation and Modifiers	59
Wipe Snapshots	67
DME Wipes	68
Types of DME Wipe Pattern	68
DME Wipe Pattern Variation and Modifiers.....	70
Relation Between DME Wipes and Other Effects	71
DME Wipe Snapshots	71
Frame Memory	73
Overview	73

Frame Memory Functions	74
Color Backgrounds.....	78
Copy and Swap	79
Video Process	83
Video Process Adjustment of a Primary Input Signal.....	83
Video Process Adjustments on a Particular Bus	83
Video Process Memory	84
Digital Multi Effects (DME)	85
Three-Dimensional Transformations.....	85
Transformation Operation Modes	90
Graphics Display	95
Three-Dimensional Parameter Display	97
DME Special Effects	97
Interpolation	111
Key Density Adjustment	112
Key Source Selection	112
Global Effects	112
External Devices	118
Shared Functions for External Device Control	118
Control of P-BUS Devices	119
Control of GPI Devices	120
VTR/Disk Recorder Control	121
Regions and Registers	124
Regions	124
Registers	125
Keyframes	127
Effects.....	127
Saving and Recalling Effects	128
Effect Attributes	128
Effect Editing	128
Time Settings.....	130
Paths	133
Effect Execution	138
Master Timelines	139
Snapshots.....	140
Snapshot Types.....	140
Snapshot Attributes	141
Utility	143
Shotbox	144

Setup	145
Overview of Setup.....	145
System Setup.....	145
Saving and Recalling Setup Data	148
Panel Setup.....	149
Switcher Setup.....	151
DME Setup.....	154
Setup Relating to DCU Input/Output	155
Setup Relating to the Router Interface and Tally Interface.....	155
Simple Connection to MKS-8080/8082 AUX Bus Remote Panel.....	156
Files	158
Macros	160

Chapter 2 Menus and Control Panel

Names and Functions of Parts of the Control Panel	164
Control Panel: Example Configuration 1 (With Standard Transition Modules)	164
Control Panel: Example Configuration 2 (With Simple Transition Modules)	166
Control Panel: Example Configuration 3 (With Compact Transition Modules).....	168
Cross-Point Control Block	169
Transition Control Block (Standard Type).....	173
Flexi Pad Control Block (Standard Type).....	177
Key Control Block.....	179
Device Control Block (Trackball)	183
Device Control Block (Joystick)	187
Keyframe Control Block	188
Numeric Keypad Control Block.....	191
Fade to Black Control Block	193
Auxiliary Bus Control Block.....	194
Menu Control Block.....	197
Memory Card/USB Adaptor Block.....	198
Utility/Shotbox Control Block	199
Transition Control Block and Flexi Pad Control Block (Simple Type)....	200
Independent Key Transition Control Block (Simple Type)	203
Downstream Key Control Block	205
Transition Control Block (Compact Type)	207

Basic Menu Operations	210
Menu Organization.....	210
Accessing a Menu	215
Interpreting the Menu Screen	216
Menu Operations	217

Chapter 3 Transitions

Basic Operating Procedure	224
Key Priority Setting	227
Setting the Key Priority in the Transition Control Block.....	227
Setting the Key Priority by a Menu Operation.....	229
Display of the Key Output Status and Key Priority	230
Selecting the Transition Type by a Menu Operation	232
Super Mix Settings	233
Color Matte Settings	234
Executing a Transition	235
Transition Indicator Function	235
Setting the Transition Rate	236
Pattern Limit.....	239
Executing an Auto Transition.....	243
Executing a Transition With the Fader Lever (Manual Transition) ...	243
Combinations of Auto and Manual Transitions	244
Non-Sync State	244
Fader Lever Operation in Bus Fixed Mode.....	245
Transition Preview	247
Independent Key Transitions	248
Basic Independent Key Transition Operations.....	248
Setting the Independent Key Transition Type by a Menu Operation..	249
Setting the Independent Key Transition Rate.....	250
Fade to Black	253
Fade to Black Operation.....	253
Setting the Fade to Black Transition Rate	253
Simple Transition	255
Basic Operations for Simple Transitions.....	255
Display of the Key Output Status and Key Priority	257
Split Fader	257
Independent Key Transitions With a Simple Transition Module.....	258

Chapter 4 Keys

Key Setting Operations Using Menus	262
Key Setting Menu	262
Key Type Setting	263
Chroma Key Composition	265
Chroma Key Adjustments	266
Selecting Key Fill and Key Source	271
Key Edge Modifications	273
Masks	279
Applying a DME Effect to a Key	283
Specifying the Key Output Destination	284
Blink Function	285
Video Processing	286
Key Setting Operations With the Key Control Block	287
Operations in the Key Control Block	287
Key Edge Modifications	291
Masks	295
Applying a DME Effect to a Key	296
Other Key Setting Operations	297
Key Snapshots	299
Key Snapshot Operations	299
Key Snapshot Operations Using a Simple Transition Module	301

Chapter 5 Wipes

Basic Procedure for Wipe Settings	304
Wipe Settings Menu	304
Wipe Pattern Selection	304
Pattern Mix	307
Setting Wipe Modifiers	309
Wipe Settings for Independent Key Transitions	322
Basic Procedure for Independent Key Transition Wipe Settings	322
Setting Independent Key Transition Wipe Modifiers	323
Wipe Snapshots	327
Saving a Wipe Snapshot	328
Recalling a Wipe Snapshot	329
Deleting a Wipe Snapshot	330

Chapter 6 DME Wipes

Basic Procedure for DME Wipe Settings	332
DME Wipe Settings Menu	332
DME Wipe Pattern Selection	332
Setting DME Wipe Modifiers	333
DME Wipe Settings for Independent Key Transitions	339
Basic Procedure for Independent Key Transition DME Wipe Settings	339
Setting Independent Key Transition DME Wipe Modifiers.....	340
DME Wipe Snapshots	341
Creating User Programmable DME Patterns	342
User Programmable DME Transition Mode	342

Chapter 7 Frame Memory

Frame Memory Operations	348
Preparations	348
Interpreting the Frame Memory Menu	348
Selecting an Input Image	350
Selecting Outputs and Target Frame Memory	351
Capturing an Image (Freeze).....	352
Recalling Images	354
Image Processing.....	356
Image Output.....	360
Image Data Management.....	362
Deleting Files	362
Renaming Files.....	363
Restoring Files.....	364

Chapter 8 Color Backgrounds

Color Background Setting Operations	368
Color Background Settings Menu	368
Basic Color Background Setting Operations.....	368

Chapter 9 Copy and Swap

Basic Copy and Swap Operations	372
Copy and Swap Menu Operations	372
Copy by Button Operation	373

Chapter 10 Misc Menu, Etc.

Misc Menu Operations	376
AUX Menu Operations	378
AUX Bus Settings	378
Video Process Settings	379
Index	381

Chapter 1 DVS-9000 Functions

Introduction	20
Features of the DVS-9000 Production Switcher System	22
Video Processing Flow	24
Signal Selection	25
Basics of Signal Selection	26
Bus Selection	26
Signal Assignment and Selection	28
Signal Name Display	31
Transitions	32
Selecting the Next Transition	32
Independent Key Transitions.....	35
Transition Types	39
Executing a Transition.....	42
Keys	46
Key Types.....	46
Key Modifiers.....	50
Key Memory.....	54
Key Snapshots	54
Blink	54
Key Default.....	55
Key Modify Clear	55
Wipes	56
Types of Wipe Pattern	56
Pattern Mix	57
Wipe Pattern Variation and Modifiers.....	59
Wipe Snapshots	67
DME Wipes	68
Types of DME Wipe Pattern	68
DME Wipe Pattern Variation and Modifiers.....	70

Relation Between DME Wipes and Other Effects	71
DME Wipe Snapshots	71
Frame Memory	73
Overview	73
Frame Memory Functions	74
Color Backgrounds.....	78
Copy and Swap	79
Video Process	83
Video Process Adjustment of a Primary Input Signal.....	83
Video Process Adjustments on a Particular Bus	83
Video Process Memory	84
Digital Multi Effects (DME)	85
Three-Dimensional Transformations.....	85
Transformation Operation Modes	90
Graphics Display	95
Three-Dimensional Parameter Display	97
DME Special Effects	97
Interpolation.....	111
Key Density Adjustment	112
Key Source Selection.....	112
Global Effects	112
External Devices.....	118
Shared Functions for External Device Control.....	118
Control of P-BUS Devices	119
Control of GPI Devices	120
VTR/Disk Recorder Control.....	121
Regions and Registers.....	124
Regions	124
Registers	125

Keyframes	127
Effects	127
Saving and Recalling Effects.....	128
Effect Attributes	128
Effect Editing.....	128
Time Settings.....	130
Paths.....	133
Effect Execution	138
Master Timelines	139
Snapshots	140
Snapshot Types.....	140
Snapshot Attributes.....	141
Utility	143
Shotbox	144
Setup	145
Overview of Setup	145
System Setup	145
Saving and Recalling Setup Data	148
Panel Setup	149
Switcher Setup.....	151
DME Setup	154
Setup Relating to DCU Input/Output	155
Setup Relating to the Router Interface and Tally Interface	155
Simple Connection to MKS-8080/8082 AUX Bus Remote Panel	156
Files	158
Macros	160

Introduction

This manual is the User's Guide for the DVS-9000/9000SF Production Switcher system supporting the SDTV signal format only. The DVS-9000 and DVS-9000SF have different numbers of M/E banks and input/output signals, but are otherwise functionally identical.

This manual refers to these generically as the "DVS-9000 system," and describes principally the operation of the system using the CCP-8000 series of center control panels.

The User's Guide for the DVS-9000 system comprises two volumes.

Contents of Volume 1

Overview of functions of the DVS-9000 system, and basic switcher operations including transitions, keys, and wipes.

Contents of Volume 2

DME effects, snapshots, keyframes, and various operations such as setup which affect the overall system.

Devices and system nomenclature

In this manual, when discussing the principal components of the DVS-9000 system, in place of the formal product names, abbreviated names characterizing the functions and features are sometimes used. When distinctions between system configurations must be drawn, the terms in the second table on this page are used.

Principal components and naming

The formal product names of the principal components of the DVS-9000 system, and the terms used in this manual are as follows.

Formal product name	Term used in this manual
DVS-9000/9000SF Production Switcher Processor	Switcher or switcher processor
BKDS-9470 DME Board Set	DME or DME board set
CCP-8000-series Center Control Panel	Control panel or center control panel
DCU-8000 Device Control Unit	DCU

System nomenclature

The following terms are used for systems, depending on the combination of installed options, and the signal format.

System configuration and features	Term for system
A system in which the center control panel has four M/E banks	4M/E system
A system in which the center control panel has three M/E banks	3M/E system
A system in which the center control panel has two M/E banks	2M/E system

Related manuals

The following manuals are supplied with the individual products of the DVS-9000 Production Switcher system.

DVS-9000/9000SF-C Switcher Processor Pack

- DVS-9000/9000SF-C Operation Manual
- DVS-9000/9000SF-C Installation Manual

BKDS-9470 DME Board Set

- BKDS-9470 Operation Manual
- BKDS-9470 Installation Manual

CCP-8000 Center Control Panel Pack

- CCP-8000 Operation Manual
- CCP-8000 Installation Manual

DCU-8000 Device Control Unit Pack

- DCU-8000 Operation Manual
- DCU-8000 Installation Manual

Features of the DVS-9000 Production Switcher System

The DVS-9000 Production Switcher system boasts extensible high performance and multifunctionality. The following are some of the principal features of this system.

System configuration flexibility

SDTV support

This system supports the SDTV signal formats 480i/59.94 and 576i/50. The format selection can be switched by a simple control panel operation.

Extensible system configuration

By suitable combination of options, the switcher can be configured with various inputs and outputs, and different numbers of M/E banks. The system offers the flexibility to change and expand as required.

When the optional DME board set is installed, the system allows you to use up to four DME channels.

Powerful external device interfaces

By connecting to a Sony routing switcher or similar, a large system can be built. From the control panel, it is also possible to operate other equipment, including VTRs and disk recorders.

Powerful tally system

The complete system including routing switcher provides an all-inclusive tally system. The system can be adapted to different applications and settings, using multiple tally outputs, including both on-air and recording tallies.

Comprehensive video manipulation

M/E banks

Each mix/effects bank (M/E bank) is equipped with four keyers, and each keyer is capable not only of chroma keying, but also independent key transitions separate from the background transitions. The four keys can be freely combined, to carry out four different program outputs.

Powerful frame memory functions

The frame memory can store 222 frames, and up to eight of these can be recalled simultaneously.

Link operation with DME

Using the BKDS-9470 DME Bord Set, a range of DME functions including DME wipes and processed keys can be handled as switcher functions. The system can interface with up to four DME units.

Designed for use in a live broadcasting environment**Flexible control panel layout**

Because of its modular design, the various sections of the control panel can be laid out as required. This allows a flexible layout appropriate to the system operation.

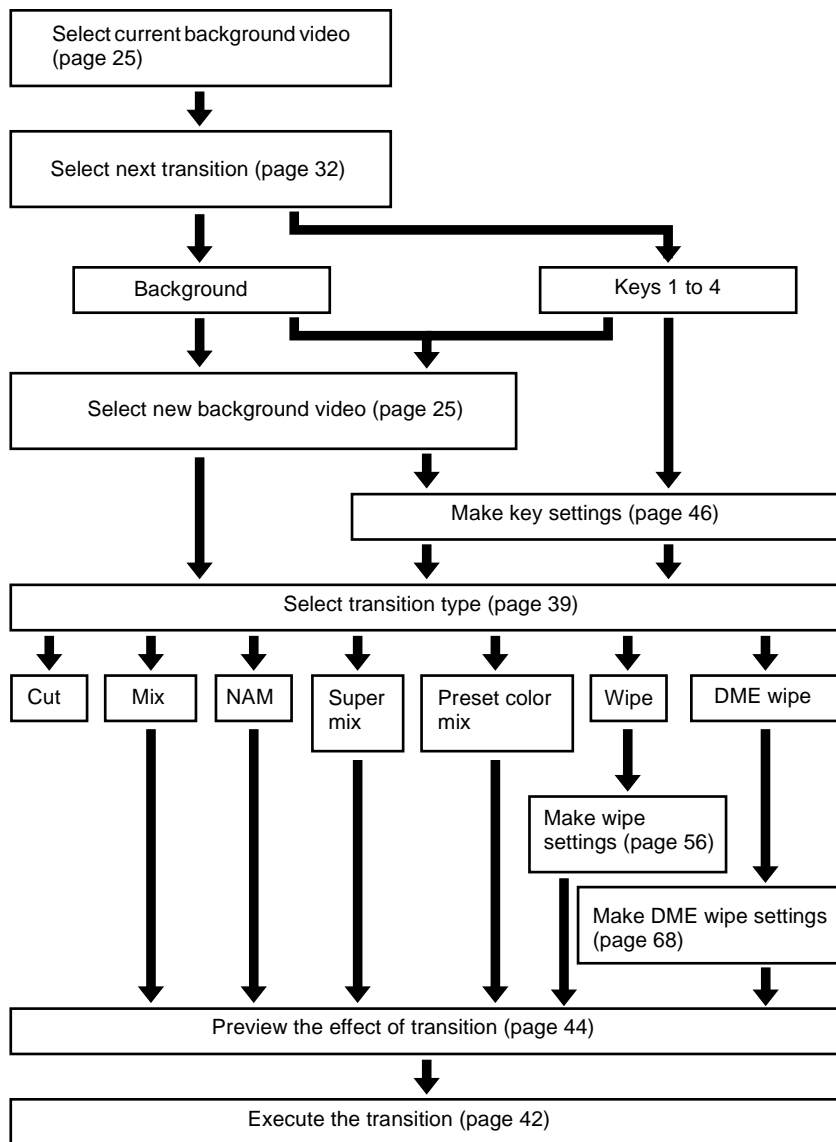
High-performance user interface

The menu control block provides a large color LCD panel, with rapid touch-panel menu selection.

The source name displays and buttons in the Flexi Pad™ and shotbox sections have color backlit LCD displays. The signal names, and graphical representations of the patterns associated with buttons provide intuitive feedback, and allow the immediate decisions that are required in a live operating environment.

Video Processing Flow

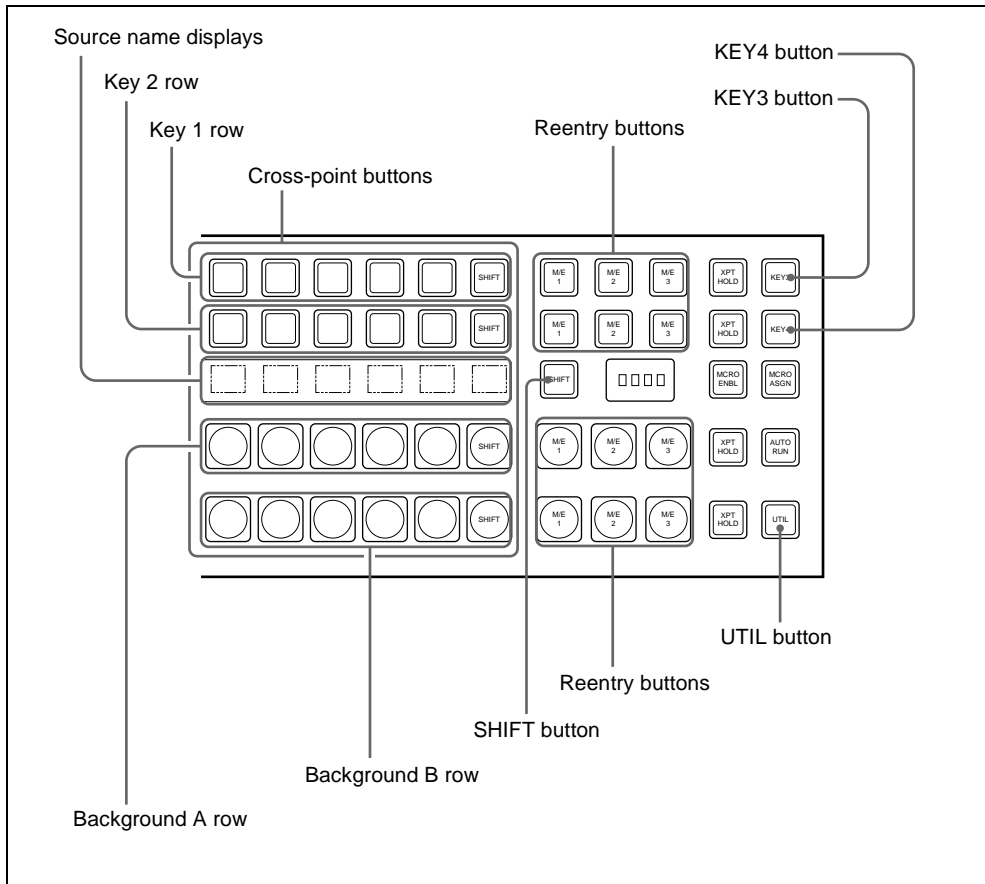
The following illustration shows the flow of operations for carrying out a transition on an M/E bank or the PGM/PST bank.



Signal Selection

You carry out signal selection with the cross-point buttons in the cross-point control block of each M/E bank or the PGM/PST bank, and the buttons in the auxiliary bus control block.

The number of buttons in each cross-point row may be 16, 24, or 32, but here the description is of the 32-button case as an example.



Cross-point control block



Basics of Signal Selection

Each of the M/E bank, PGM/PST bank and auxiliary bus control block has 32 cross-point buttons and three reentry buttons (four in the case of the auxiliary bus control block).

These buttons are identified by numbers common to all of the banks and block, and a signal is assigned to each number.

The basis of signal selection is to select, in a cross-point button row, the cross-point button to which is assigned the desired signal.

Reentry buttons

To use the output of one M/E bank as background input to another bank, use the reentry buttons [M/E1], [M/E2], and [M/E3] (on the auxiliary bus control block, [M/E1], [M/E2], [M/E3], and [PGM]) in the cross-point control block of the destination bank.

For example, to feed the output from the M/E-1 bank as the background B input to M/E-2, in the M/E-2 cross-point control block, press the [M/E1] button in the background B row.

Bus Selection

Each row of 32 cross-point buttons is shared by multiple buses.

For example, in the M/E-1 bank, the key 1 row of buttons can be assigned either to the key 1 bus or to the key 3 bus. The [KEY3] button switches between these two assignments.

To assign a bus to the cross-point buttons in the auxiliary bus control block, press one of the AUX delegation buttons to select the bus.

The following table illustrates the correspondence between buses and cross-point button rows, and the delegation operations.

Bank	Bus name	Cross-point button row	Delegation operation
M/E-1, M/E-2, M/E-3	Background A bus	Background A row	–
	Background B bus	Background B row	–
	Key 1 bus	Key 1 row	Turn off the [KEY3] button
	Key 2 bus	Key 2 row	Turn off the [KEY4] button
	Key 3 bus	Key 1 row	Turn on the [KEY3] button
	Key 4 bus	Key 2 row	Turn on the [KEY4] button

Bank	Bus name	Cross-point button row	Delegation operation
PGM/PST	Program bus	Program row	–
	Preset bus	Preset row	–
	DSK 1 bus	DSK1 row	Turn off the [DSK3] button
	DSK 2 bus	DSK2 row	Turn off the [DSK4] button
	DSK 3 bus	DSK1 row	Turn on the [DSK3] button
	DSK 4 bus	DSK2 row	Turn on the [DSK4] button
M/E-1, M/E-2, M/E-3, PGM/PST	Utility 1 bus	Background A row	When [UTIL] button mode is Hold, hold down the [UTIL] button
	Utility 2 bus	Background B row	
	DME external video bus	Key 1 row	Hold down the [UTIL] button
	DME utility 1 bus	Key 2 row	Hold down the [UTIL] button, and press the [KEY4] button, turning it off
	DME utility 2 bus		Hold down the [UTIL] button, and press the [KEY4] button, turning it on



Bank	Bus name	Cross-point button row	Delegation operation
Auxiliary bus control block	AUX1 to AUX48 buses	1st row, 2nd row	Turn on the appropriate buttons in accordance with the signal assignment made in the Setup menu.
	MONITOR 1 to MONITOR 8 buses		
	Frame memory source 1 and frame memory source 2 buses		
	DME 1 to DME 4 video buses		
	DME 1 to DME 4 key buses		
	Edit preview bus		
	M/E-1 UTILITY 1 and M/E-1 UTILITY 2 buses		
	M/E-2 UTILITY 1 and M/E-2 UTILITY 2 buses		
	M/E-3 UTILITY 1 and M/E-3 UTILITY 2 buses		
	P/P UTILITY 1 and P/P UTILITY 2 buses		
	M/E-3 Key 1 fill to M/E-3 Key 4 fill buses		
	M/E-3 Key 1 source to M/E-3 Key 4 source buses		
	DSK 1 fill to DSK 4 fill buses		
	DSK 1 source to DSK 4 source buses		
	M/E-1 external DME bus		
	M/E-2 external DME bus		
	M/E-3 external DME bus		
	P/P external DME bus		
	DME UTILITY 1 and DME UTILITY 2 buses		

Signal Assignment and Selection

Assigning signals to buttons

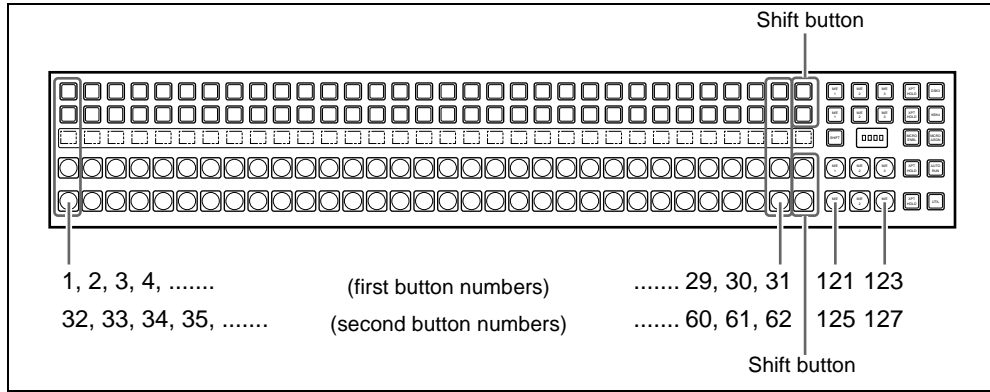
Each of the 32 cross-point buttons and reentry buttons has a corresponding button number, to which you assign a signal.

In addition to the signals input to the PRIMARY INPUTS 1 to 80 connectors on the rear panel of the switcher, you can also select signals generated within the switcher.

Each button has assigned to it a video signal and a key signal, forming a pair. You can set these video and key combinations in a Setup menu.

For details of Setup menu operations, see “Cross-Point Settings (Xpt Assign Menu)” in Chapter 16 (Volume 2).

Cross-point button control block button numbers



On each M/E bank and the PGM/PST bank, each cross-point button and reentry button has two button numbers, and you use the shift button to switch between these numbers.

In the case of a 32-button layout, the button numbers are as follows.

Cross-point control block button numbers

Button	Number when the shift button is not pressed	Number when the shift button is pressed
From the left end to the 31st button	1 to 31	32 to 62
Reentry buttons	121 to 123	125 to 127

Switching button numbers

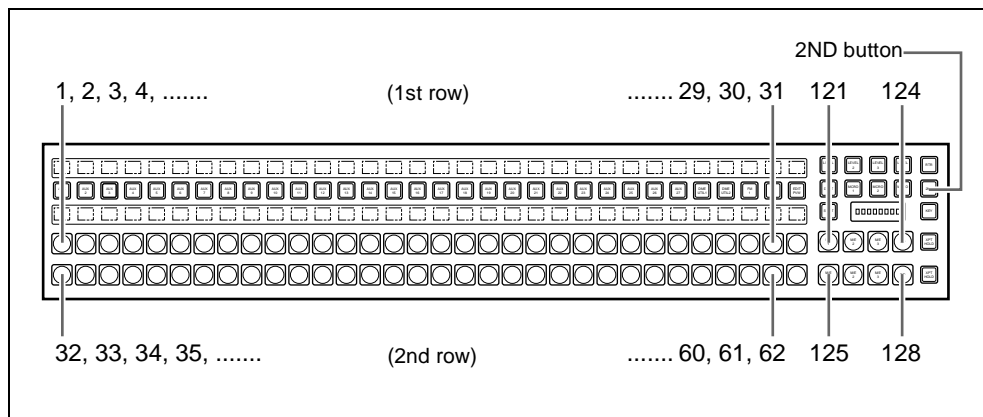
The rightmost (32nd) button functions as a shift button.

(The shift button function can be disabled in a Setup menu.)

When selecting the signals of button numbers 1 to 31, press the cross-point button for the desired signal.

To select button numbers 32 to 62, hold down the shift button, and press the cross-point button for the desired signal.

Button numbers in the auxiliary bus control block



When the [2ND] button is unlit

The cross-point buttons and reentry buttons in the auxiliary bus control block have separate upper (1st row) and lower (2nd row) numbers.

In the case of a 32-button layout, the button numbers are as follows.

Auxiliary bus control block button numbers ([2ND] button unlit)

Button	Button	Button numbers
1st row	From the left end to the 31st button	1 to 31
	Reentry buttons	121 to 124
2nd row	From the left end to the 31st button	32 to 62
	Reentry buttons	125 to 128

When the [2ND] button is lit

Different buses can be assigned to the 1st-row buttons and 2nd-row buttons. When the 32nd button is set as a shift button, the 1st-row buttons and 2nd-row buttons both have the following button numbers.

Auxiliary bus control block button numbers ([2ND] button lit)

Button	Number when the shift button is not pressed	Number when the shift button is pressed
From the left end to the 31st button	1 to 31	32 to 62
Reentry buttons	121 to 124	125 to 128



Signal Name Display

You can attach a name (source name) to each signal assigned to a cross-point button, with a maximum of 16 characters.

- The source name displays in the cross-point control block and auxiliary bus control block show the source names of the video signals assigned to numbers 1 to 31.
- To display the source names for numbers 32 to 62, press the [SHIFT] button to the right of the source name displays.
- To display the source names of the key signals assigned to buttons, hold down the [Split] button in the key control block or the [KEY] button in the auxiliary bus control block.

Colors of lit cross-point buttons

In a particular row of cross-point buttons, only the last pressed button is effective, and lights amber or red. The amber indicates the “low tally” state, and the red indicates the “high tally” state, to indicate whether or not the selected signal appears in the final output video.

Significance of colors of lit cross-point buttons

Color	State	Significance
Amber	Low tally	Does not appear in final output video
Red	High tally	Appears in final output video

Transitions

In the M/E banks and PGM/PST bank, the switch from the current video stream (appearing on the corresponding program monitor) to a new video stream is referred to as a transition.

Selecting the Next Transition

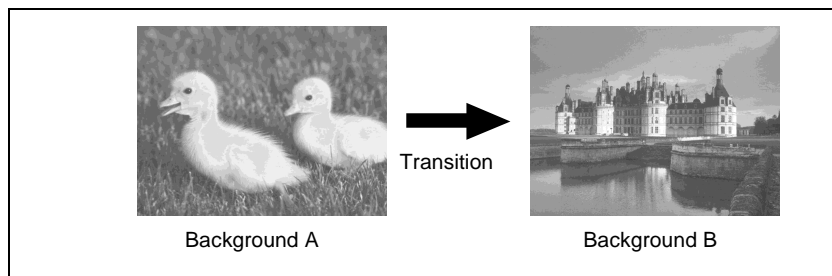
To execute a transition, it is first necessary to decide how the image will be changed as a result of the transition. This selection is carried out using the next transition selection buttons (*see page 173*) in the transition control block of the M/E or PGM/PST bank.

For details of operations, “Basic Operating Procedure” (page 224).

In the M/E banks and PGM/PST bank, you can change one of the images, the background, and keys 1 to 4 (downstream keys 1 to 4 in the PGM/PST bank), and also vary combinations of these simultaneously. The following are examples of transition.

Changing the background

A background transition switches from the video currently selected on the background A bus (the current video) to the video selected on the background B bus (the new video).

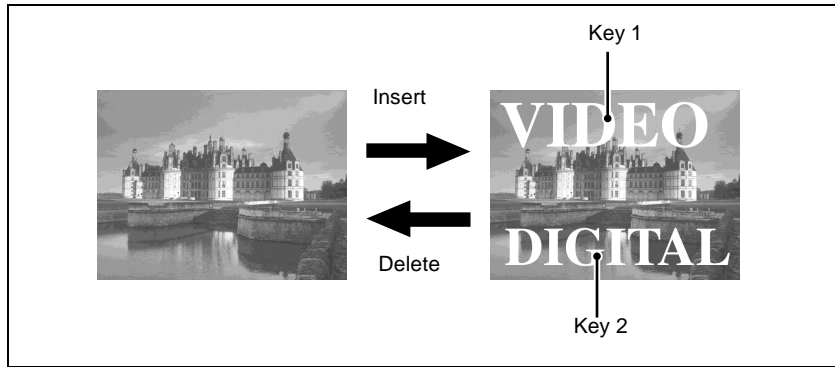


In the default selection of flip-flop mode (*see page 43*), the background always switches in the direction from the A bus to the B bus. When the transition completes, the cross-point selections on the A and B buses are interchanged.

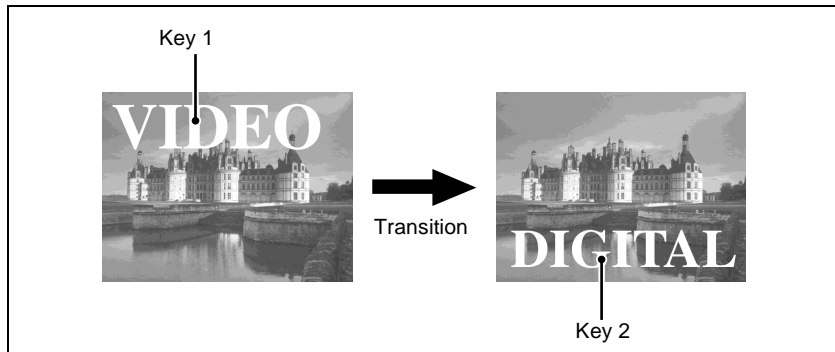
Inserting and deleting a key

You can insert one or more of the four keys (downstream keys on the PGM/PST bank).

If you select a key which is already inserted, the transition will delete the key. A simultaneous combination of deleting and inserting keys is also possible.



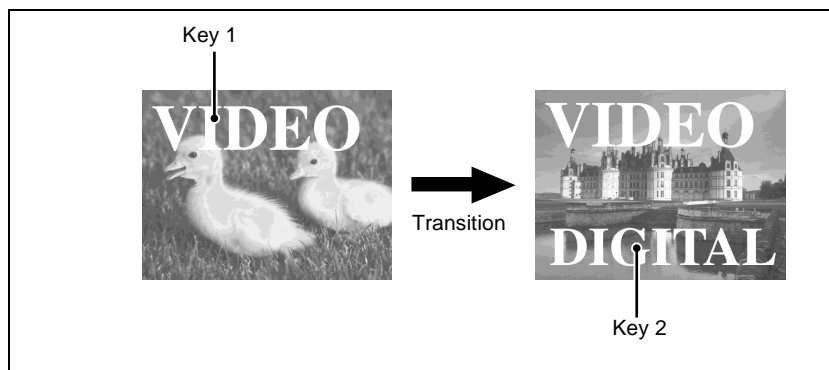
Inserting or deleting key 1 and key 2



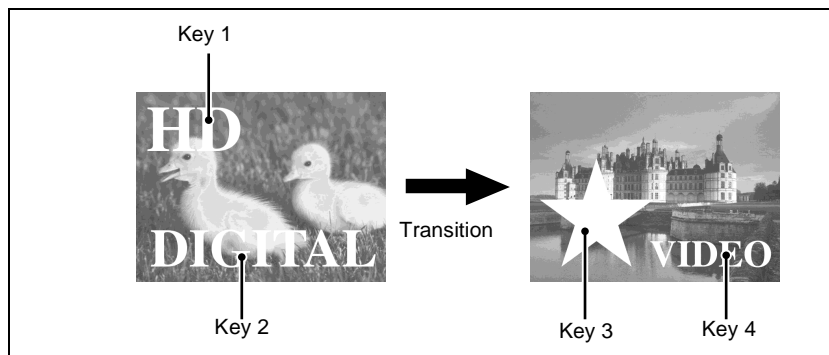
Deleting key 1 and inserting key 2

Simultaneously changing the background and keys

You can change any of the four keys (downstream keys on the PGM/PST bank) and the background at the same time.



Changing the background and key 2 simultaneously



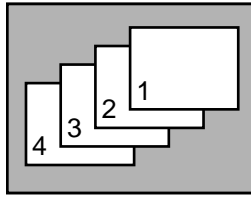
Changing the background and keys 1 to 4 simultaneously

Selecting the key priority

If a number of keys are already inserted in the current video, you can check or change the key priority, that is to say, the order in which the keys are overlaid. When a key priority ([KEY PRIOR]) is selected as the next transition, you can also change the key priority in the new video.

For details of this operation, see “Key Priority Setting” (page 227).

The key priority values go from 1 to 4, with a higher priority key being “in front” as seen on the screen.



Priority sequence on the screen

Independent Key Transitions

What is an independent key transition?

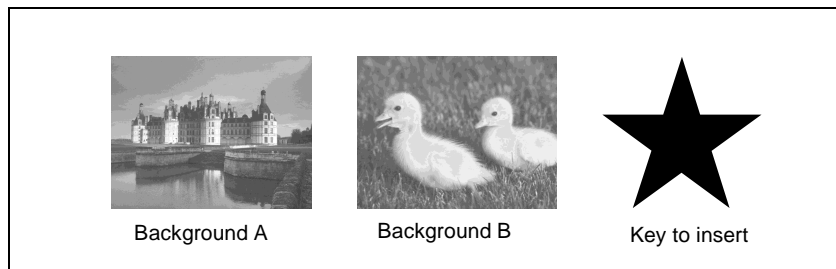
In addition to common transitions, it is possible to carry out independent transitions on the keys of the M/E banks and PGM/PST bank. These are called “independent key transitions.”

By carrying out an independent key transition in combination with a common transition, different transition types can be used for the background and keys. It is also possible to use different transition types for key insertion and key deletion by means of a Setup menu setting.

For details of this operation, see “Basic Independent Key Transition Operations” (page 248).

The following description compares the independent key transition with a common transition, taking a simultaneous change of the background and key as an example.

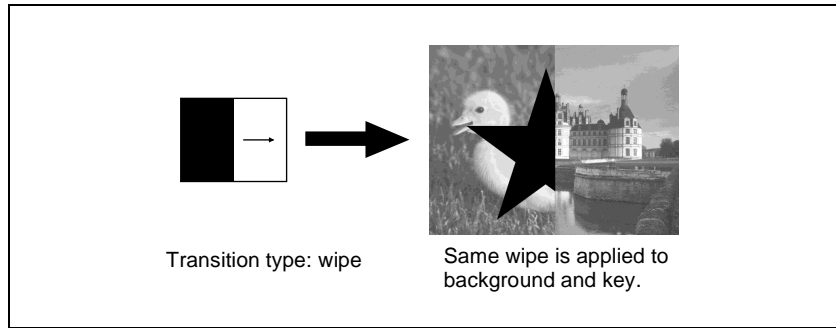
Video used in the transition





Effect of a common transition

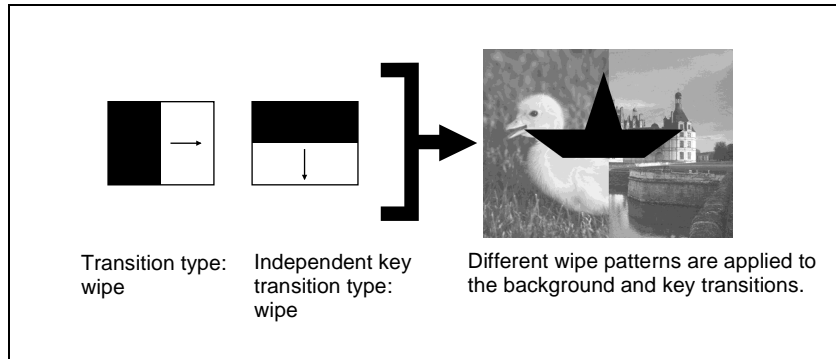
In the case shown in the above illustration, carrying out a common transition produces the following change in the image.



Effect of a common transition

Effect of use with an independent key transition

The key is inserted with an independent key transition as the background changes with a common transition, providing the following result.



Effect of a background transition and independent key transition

Combining other transitions with independent key transitions

When you set a common transition and a key independent transition for the same key, you can apply two different effects such as a wipe and mix (dissolve) (*see page 39*) to the key simultaneously.

When carrying out such a combination of transitions simultaneously on a key as auto transitions (*see page 42*), the result depends on the timing of pressing the respective [AUTO TRANS] buttons.

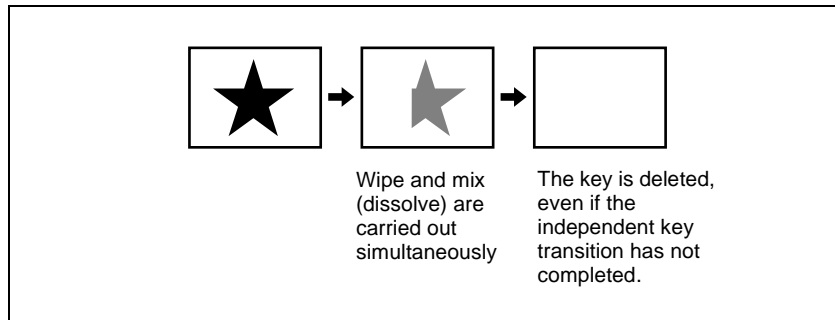
Simultaneous execution

If the [AUTO TRANS] buttons for the two transitions are pressed simultaneously, the following is the result.

Note that in both cases the common transition is a wipe and the independent key transition is a mix (dissolve).

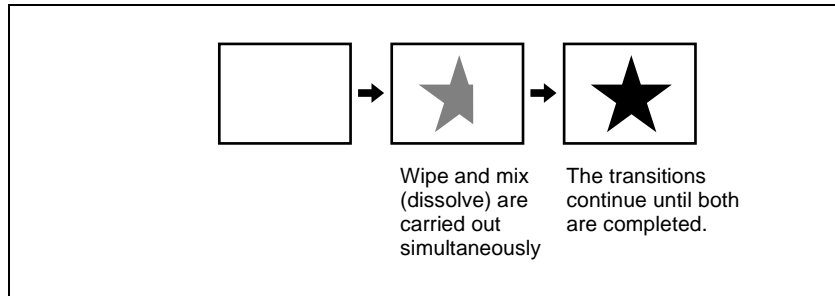
Deleting a key with simultaneous transitions: With the key inserted, it is deleted simultaneously with the two transitions.

When the common transition completes, even if the independent key transition is still not completed, the two end simultaneously.



Deleting a key with simultaneous transitions

Inserting a key with simultaneous transitions: With the key not inserted, it is inserted simultaneously with the two transitions. If the common transition or independent key transition ends first, the other continues to completion.



Inserting a key with simultaneous transitions

Time offset execution

If the [AUTO TRANS] buttons for the two transitions are pressed with a time offset, the following is the result.

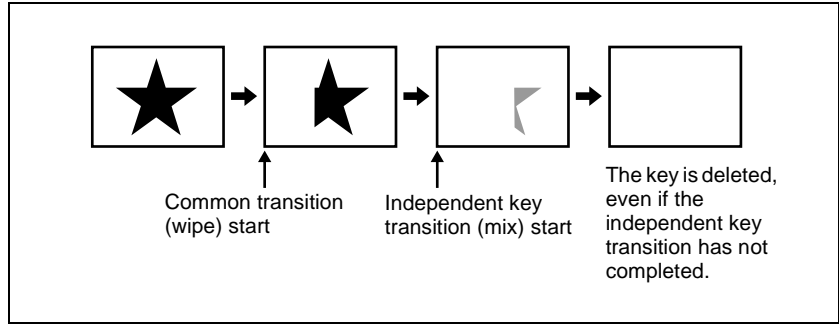
Note that in both cases the common transition is a wipe and the independent key transition is a mix (dissolve).



Time offset execution with the key inserted: With the key inserted, it is deleted with the two transitions acting with a time offset.

Whichever button is pressed first, when the common transition completes, even if the independent key transition is still not completed, the two end simultaneously.

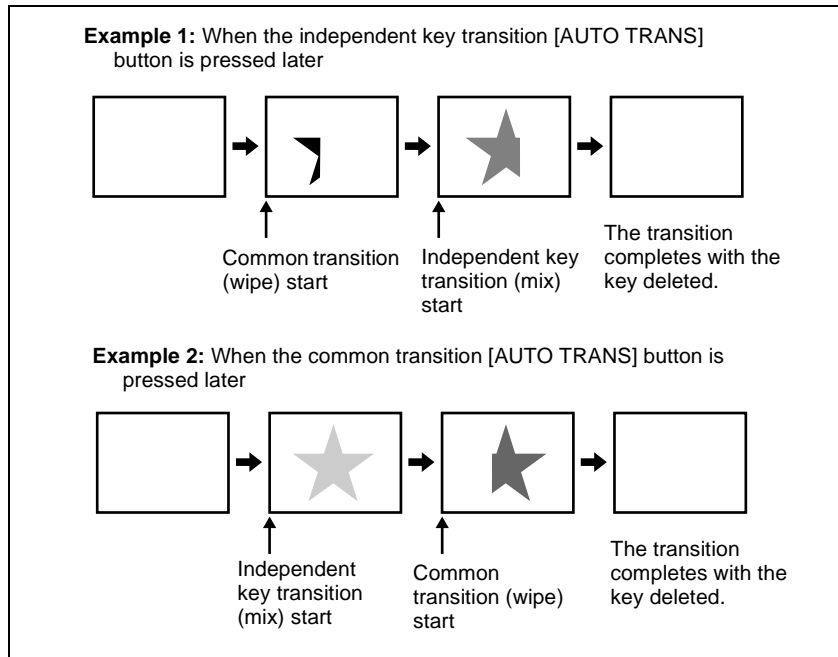
Example: When the independent key transition [AUTO TRANS] button is pressed later



Time offset execution with the key inserted

Time offset execution with the key not inserted: With the key not inserted, it is inserted with the transition whose [AUTO TRANS] button is pressed first.

Since the key is then in the inserted state, with the transition whose [AUTO TRANS] button is pressed later, the key is deleted. When the key is completely deleted, both transitions complete.



Time offset execution with the key not inserted

Transition Types

Selecting the transition type determines the way in which the transition occurs. Carry out the type selection with the transition type selection buttons in the transition control block of the M/E or PGM/PST bank.

For details of this operation, see “Basic Operating Procedure” (page 224).

The following are the transition types.

Mix

This is a dissolve, in which the new video progressively fades in over the current video, with the sum of the two video outputs maintained constant. At the mid-point of the transition (when the fader lever is in the center position), the output of each is 50%.

This transition type can also be selected for an independent key transition. In this case, the key either dissolves in or dissolves out similarly, with the progress of the transition.

NAM (non-additive mix)

In this dissolve, the current video and new video signals are compared, and the signal with the higher luminance level is given priority in the output. The current video is maintained at 100% output for the first half of the transition as the new video increases progressively to 100%, then the current video is progressively reduced from 100% to zero in the second half with the new video maintained at 100% output.

Note

This transition type is not available for an independent key transition.

Super mix

In this dissolve, the current video is maintained at 100% output for the first half of the transition as the new video is mixed while increasing progressively to 100%, then the current video is progressively reduced from 100% to zero in the second half with the new video maintained at 100% output.

Note that you can set the output levels of the current and new video signals at the mid-point of the transition, in the range 0 to 100%. (See “*Super Mix Settings*” (page 233).)

Note

This transition type is not available for an independent key transition.

Preset color mix

This is a two-stage dissolve, comprising two transitions, the first a dissolve to a color matte, and the second from the color matte to the new video.

In the first transition, the current video is replaced by the color matte in a mix (dissolve), then in the second transition the color matte is replaced by the new video also in a mix (dissolve). You can specify the color matte by luminance, saturation, and hue values. (See “*Color Matte Settings*” (page 234).)

Notes

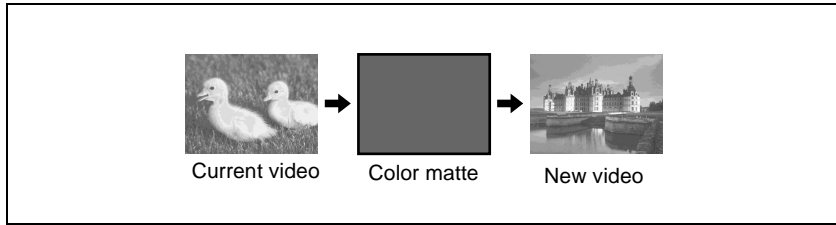
- This transition type is not available for an independent key transition.
- In the bus fixed mode, a preset color mix cannot be used.

One-stroke mode and one-time mode

- You can make a setting such that a preset color mix is carried out in a single transition. This is called “one-stroke mode.”
- You can also make a setting such that when a preset color mix is completed, the next transition switches to the previous transition type automatically. This is called “one-time mode.”

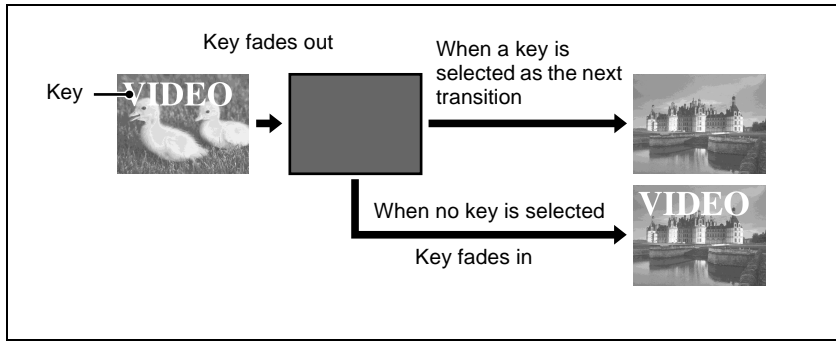


When only the background is changed



Preset color mix (changing background only)

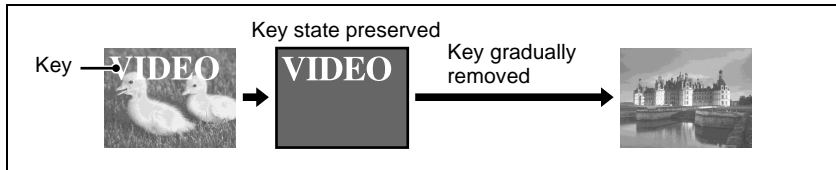
When a key is inserted



Preset color mix (transition including key)

By means of a Setup menu setting, it is possible to preserve the key state while carrying out the color matte mix.

When, with a key inserted, a key is selected in the next transition



Preset color mix (when set to preserve key state)

Wipe

A wipe replaces the current video by the new video according to a predetermined pattern. This transition type can also be selected for an independent key transition.

For details, see “Wipes” (page 56) and Chapter 5 “Wipes” (page 303).



DME wipe

Using a DME effect, it is possible to obtain a transition to a new image from the current image, as in a wipe. You can also use this transition type as an independent key transition.

For details, see “DME Wipes” (page 68) and Chapter 6 “DME Wipes” (page 331).

Note

To carry out DME wipes requires the BKDS-9470 DME Board Set.

Cut

A cut switches instantaneously from the current video to the new video. When the next transition is a key transition, the key cuts in or out instantaneously.

Executing a Transition

There are two modes of executing a transition: an auto transition by button operation or a manual transition using the fader lever.

It is also possible to combine both methods, taking control with the fader lever of an auto transition which has partly completed, or complete a transition started with the fader lever as an auto transition.

By combining common transitions with independent key transitions, different transition types can be applied to the background and keys, for example allowing a key wipe combined with a background dissolve. (*See “Executing a Transition” (page 235).*)

Auto transitions

Cut

A cut switches instantaneously from the current video to the new video. When the next transition is a key transition, the key cuts in or out instantaneously.

Auto transition

The transition from the current video to the new video is carried out automatically at a constant rate, using the transition effect selected as the transition type.

You can set the transition rate in advance. (*See “Setting the Transition Rate” (page 236).*)



Manual transitions

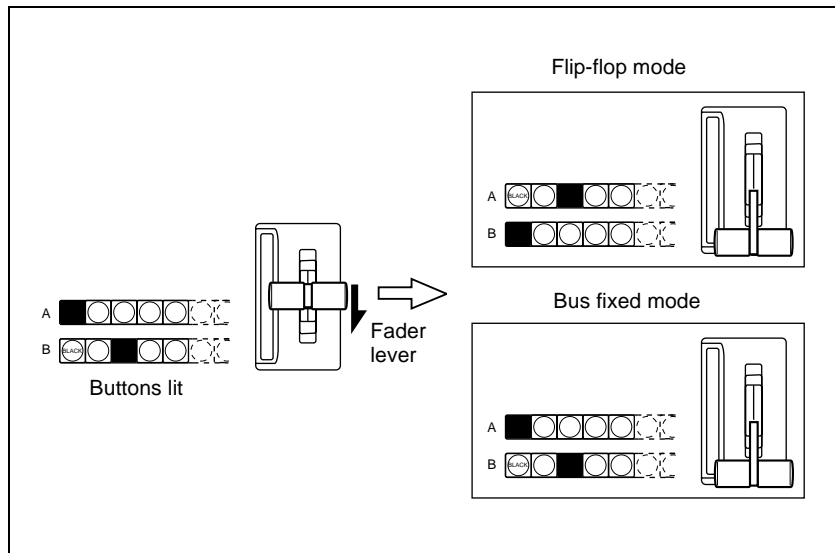
Using the fader lever, you can manually control the progress of the transition. Moving the fader lever from one end of its travel to the other completes the transition.

Flip-flop mode and bus fixed mode

The following describes the difference between flip-flop mode and bus fixed mode, taking an M/E bank as an example; the functionality is the same, however, on the PGM/PST bank.

Normally, when a background transition is carried out on an M/E bank, the signals selected on the A and B rows of cross-point buttons are interchanged at the end of the transition. That is to say, except during a transition, the background output is always from the background A bus. This is called “flip-flop mode.”

The alternative is known as “bus fixed mode,” in which there is no bus interchange. In this mode, when the fader lever is at the top of its travel the output from the A bus is always 100%, and when the fader lever is at the bottom of its travel the output from the B bus is 100%.



Flip-flop mode and bus fixed mode

For details of fader lever operation in bus fixed mode, see page 245.

Transition preview

With the preview output of the M/E banks and PGM/PST bank, you can check the effect of a transition in advance. To carry out a transition preview, press the [TRANS PVW] button in the transition control block. (See “*Transition Preview*” (page 247).)

Note

In multi-program mode, DSK mode (page 152) or bus fixed mode (page 43), it is not possible to carry out a transition preview.

Pattern limit

When a wipe or DME wipe pattern is selected for the transition, you can specify the range of movement of the wipe pattern through the course of the transition, for each bank independently.

When the pattern limit function is enabled, carrying out a transition results in the following effect for example settings.

- When the limit value is set to 50%, the effect at the end of the transition is the same as when the fader lever is at the center position in the normal case (with the pattern limit function disabled); the wipe pattern does not complete.
- When the limit value is set to 0%, the wipe effect is completely disabled, and carrying out the transition produces no change in the image.
- When the limit value is set to the maximum 100%, the image changes in exactly the same way as when the pattern limit function is off, but when the transition is completed, the cross-point selections on the background A and B buses do not interchange.

You can specify the limit value either by entering a numeric value in the menu, or by operating the fader lever to set the fader lever position. (See “*Pattern Limit*” (page 239).)

Note

The pattern limit function is not available in an independent key transition.

Fade to black

The PGM/PST bank provides a fade-to-black function, controlled with the [FTB] button in the fade to black control block. (See “*Fade to Black*” (page 253).)

Note

In multi-program mode or DSK mode, it is possible to carry out a fade-to-black on a number of programs simultaneously.

You can also make a Setup menu setting such that a fade-to-black does not apply to particular programs.

For details of the setting, see “Settings Relating to Video Switching (Transition Menu)” in Chapter 16 (Volume 2).



Keys

A key is an effect in which a part of the background image is replaced by an image or superimposed text. The signal determining how the background is cut out is termed “key source,” and the signal that replaces the cut-out part is termed “key fill.” The system component responsible for processing a key is referred to as a keyer.

Each M/E bank and the PGM/PST bank has four keyers, and all of these keyers provide the same functions.

Key Types

The key type indicates the manner in which the key source signal is used to cut out the background. In each bank, you can use the following key types. You can select the key type using the key type selection buttons in the key control block, or by a setting in the Type menu for the keyer. (*See “Key Type Setting” (page 263).*)

- Luminance key
- Linear key
- Color vector key
- Chroma key
- Wipe pattern key
- Key wipe pattern key

Luminance key

The background is cut out according to the luminance (Y) of the key source signal, and at the same time the key fill signal is cut out and then added to the background signal.

Linear key

This is a type of luminance key, but there is a reduced variability in gain, allowing more precise adjustment.

Color vector key

The key signal is created from a combination of the luminance and chrominance components of the key source signal. When perfect keying is not possible with a luminance key, this allows a key signal to be created even if the luminance level is low, provided that the colors have high saturation.

Clean mode

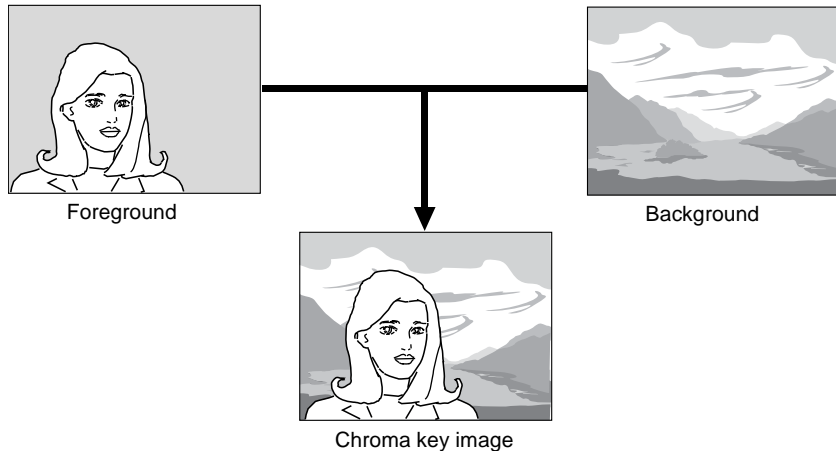
In a luminance key, linear key or color vector key, you can enable the clean mode. When the clean mode is on, the key source does not affect the key fill, which is added unchanged to the background. This improves the keyed image quality, but means that the part of the key fill signal which is not to be inserted must be completely black, or it will color the background. You set the clean mode with the Type menu of the respective keyer. (See “Setting the key type in a menu” (page 263).)

Note that in the following situations, the clean mode goes off, and cannot be turned on.

- When the key type is a pattern key
- When key inversion is on
- When the key fill is a matte
- When the key edge is an outline
- When the key edge is normal with soft edge being on
- When fine key is on
- When the key positioner is on

Chroma key

A key signal based on a particular color is used to cut out the background, and the key fill is then inserted. The inserted signal is also referred to as the foreground, and the composite image is called a chroma key image.



Normal mix and additive mix

In creating a chroma key image, either a normal mix or an additive mix can be used. To select which, use the Type>Chroma Adjust menu for the keyer. (See “Chroma Key Composition” (page 265).)



Normal mix: The foreground is cut out with the key signal, and then combined with the background, which has also been cut out with the key signal.

Additive mix: The background, which has been cut out with the key signal, is combined with the unshaped foreground. This is effective for a natural-looking composite when the scene includes glass or other translucent objects.

Plane function

In an additive mix, the foreground is not shaped by the key signal, and variations in the (blue) background appear in the composite image. To prevent this, it is possible to set a particular luminance level for the background, and any parts below this level are cut forcibly.

Methods of adjusting the composite obtained from chroma keying include automatic adjustment with the auto chroma key function, and manual adjustment carrying out the necessary processing separately. The optimum results will be obtained by first carrying out adjustments with the auto chroma key function, then making any fine adjustments as required.

The following manual adjustments are possible.

Key active

When this function is off, only the foreground is output and you can make adjustments of color cancel (*see the next paragraph*).

Color cancel

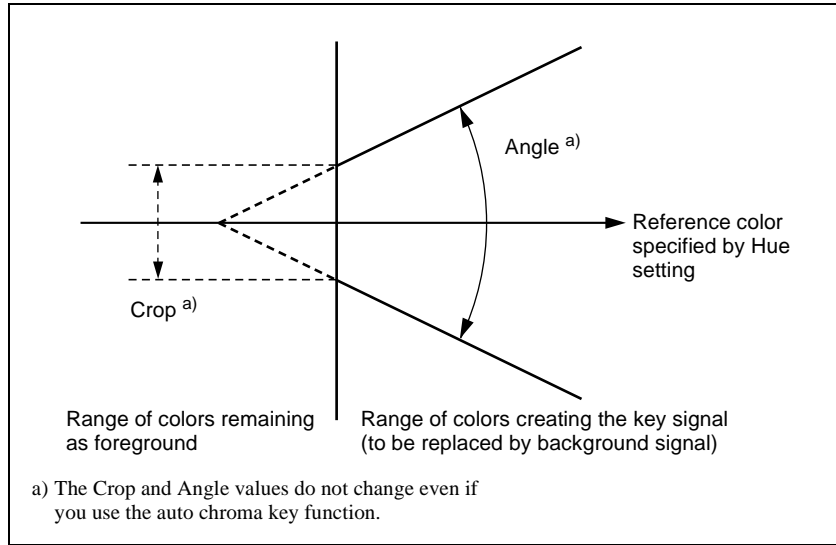
If the foreground image includes shades of the background color, set this function to ON to remove the color from the foreground image.

Chroma key window

You can adjust the range over which the key signal is determined as matching the specified hue. When this adjustment is off the default ranges are used.

Chroma keying generates a key signal based on a particular color (reference color) in the foreground (typically a plain blue background), and the “window” refers to the range of colors which are regarded as matching this specified reference color to create the key signal.

As seen on a vectorscope (that is, in the hue-saturation color space), the range for this matching corresponds to a truncated sector. This range is specified by two parameters: the “Angle” parameter, which determines the range of the hue parameter, and the “Crop” parameter, which determines the degree of truncation (*see the following figure*).



Window adjustment

Y balance

In normal chroma keying, the key signal is based on the chrominance component only, and all elements of the foreground with the same hue are replaced by the background. Using the Y balance function, you can specify a luminance level range within which the key is active, and replace the specified part by the background.

You can use the Y balance function independently on the key signal for the composition and the key signal for the color cancel function. When applied to the key signal for the composition, this produces the foreground with the color cancel effect applied. This can therefore be used to provide an impression of smoke, for example.

When the Y balance function is applied to the color cancel key, the relevant part is output in its original color without canceling, and therefore it is possible to combine colors which are the same color as the background (i.e. typically blue) in the foreground.

Chroma key shadow

This function provides a more realistic treatment when the shadow of an object in the field of view falls on the blue background. Since parts of the blue background darker than a specified intensity are treated as shadows, there is no effect on cutting out of the foreground.

Video signal adjustment

You can vary the foreground signal gain, or change the hue. There are separate adjustments for the gain of the overall video signal, and Y and C components.

For details of video adjustment operations and the adjustment items, see “Chroma Key Adjustments” (page 266).

Wipe pattern key

This uses the wipe pattern selected for a transition as the key source.

Key wipe pattern key

This uses the wipe pattern selected for an independent key transition as the key source.

Note on wipe pattern modifiers

In a wipe pattern key or key wipe pattern key, you can apply various modifications, depending on the pattern used, and the modifiers in common with a wipe.

However, modifiers which relate to the wipe direction and edge are not reflected.

Key Modifiers

Edge modifiers

You can apply borders and other effects to the edge of the key. (See “Key Edge Modifications” (pages 273 and 291).)

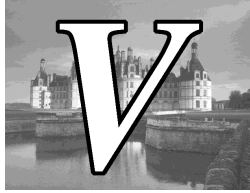
Normal

This is the state with no key edge modifiers applied.

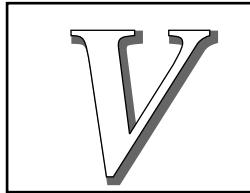


Border

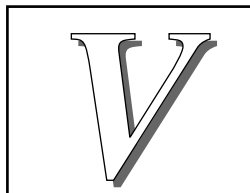
This applies a uniform width border to the edge of the key. You can adjust the border width and density. You can also enable the separate edge function, and adjust the top, bottom, left, and right border widths separately.

**Drop border**

This applies a border below and to the right for example, of the key. You can adjust the border width, position, and density.

**Shadow**

This applies a shadow below and to the right for example, of the key. You can adjust the shadow width, position, and density.





Outline

This uses the outline of the original key as the key. You can adjust the width and density of the outline. You can also enable the separate edge function, and adjust the top, bottom, left, and right outline widths separately.



Emboss

This applies an embossing effect to the outline of the key. You can adjust the width and position of the embossing, and the density. You can adjust the density separately for key fill and key edge. When embossing is on, the Fine Key and zabton functions go off.

Soft edge

This softens the edge of the key.

Zabton

This inserts a translucent pattern behind a key. You can adjust the pattern size, softness, density and color.

Edge type and key fill/key source position

The key edge modification function has two modes: a mode (“key drop ON mode”) in which the key fill/key source position moves downward, and a mode (“key drop OFF mode”) in which it does not move downward.

Key drop ON mode: The key fill/key source position moves downward by eight scan lines or four scan lines. When a drop border or shadow is selected, it is possible to apply a border to the top edge of the key.

Key drop OFF mode: The key fill/key source position does not move. When a drop border or shadow is selected, it is not possible to apply a border to the top edge of the key.

In the key drop ON mode, a menu setting selects between the mode (“4H mode”) in which the key fill/key source position is lowered by four scan lines, and the mode (“8H mode”) in which the key fill/key source position is lowered by eight scan lines.

When [Fine Key] is on, the edge width is forced to the range 0.00 to 4.00.

Note that in the following situations, the key drop mode is forcibly set to ON.

- When the edge type is border, outline, or emboss

- When the edge type is normal with soft edge being on
- When [Fine Key] is on

Edge fill

When a border, drop border, or shadow modifier is selected, you can select a signal to fill these edge effects.

The edge fill may be either the signal from the dedicated color matte generator, or the signal currently selected on the utility 1 bus.

In the case of an outline, there is no edge fill signal selection, because the key fill signal fills the outline, and the rest of the image remains as the background. For the emboss effect, in place of the edge fill signal, the emboss fill matte 1 and emboss fill matte 2 signals are used.

Masks

A mask is used to inhibit the effect of a key over a part of the image. This allows parts of the background which would otherwise be keyed to be protected, or to correct the key if it is not of the desired shape.

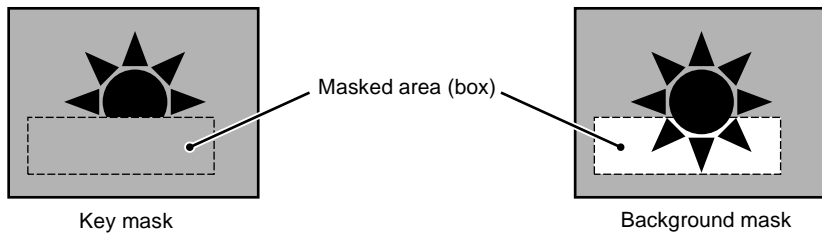
For details of masking operations, see “Masks” (pages 279 and 295).

Key mask and background mask

There are two types of mask: a key mask and a background mask.

Key mask: This masks out a part of the key, which will result in the background appearing.

Background mask: This masks out a part of the background, which will result in the key fill appearing.



Main mask and subsidiary (“sub”) mask

Each keyer allows two masks to be used simultaneously, and these are referred to as the main mask and the sub mask. The signal that determines the mask shape and size is termed the mask source, and different sources are used for the main mask and sub mask.

Main mask: This uses the signal from the dedicated box generator provided on each keyer, or the signal from the dedicated pattern generator as the



mask source.

When the box generator is selected, a rectangular mask is formed. You can adjust the positions of the four sides of the box separately.

When the pattern generator is selected, you can select the pattern and apply modifiers.

Sub mask: This uses the wipe generator signal or the signal selected on the utility 1 bus on the M/E or PGM/PST bank, as the mask source.

When the wipe generator is selected, the patterns and the pattern modifiers are the same as in a wipe transition.

Key Memory

The key memory function allows the keyer settings on each cross-point button to be automatically stored, so that the next time the same cross-point button is selected these settings are recalled automatically.

There are two modes for key memory: simple mode and full mode.

The parameters stored in each mode are as follows.

Simple mode: key type, clean mode (including the plane setting for chroma keying), key position, key inversion, and adjustment values for the particular key type (Clip, Gain, Density, Filter, etc. This includes color vector key, wipe pattern key, key wipe pattern key, and chroma key.

However, in the case of a chroma key, it excludes color cancel, Y balance, foreground CCR, window, and shadow.)

Full mode: All settings except transition (the same parameters as simple mode, [Fine Key], key modifiers, main and sub mask settings, chroma key detailed settings, and so on)

Key Snapshots

Key settings other than the key on/off status and the key priority can all be instantaneously saved in a dedicated register, for recall when required. A key snapshot comprises three values: a cross-point button number, key memory full mode, and independent key transition, and can be called in any combination. There are four key snapshot registers for each keyer.

For details of key snapshot operations, see “Key Snapshots” (page 299).

Blink

The blink function provides the following effects.

Key blink: The key is inserted and deleted at the specified frequency.

You can also set the frequency and the proportion of the cycle for which the key is inserted.

Edge blink: Key fill and key edge fill are interchanged at the specified frequency. You can specify both the frequency and the proportion of the cycle for which the interchange occurs.

The blink settings are in the Transition menu for each key. (See “*Blink Function*” (page 285).)

Key Default

With a simple operation you can return the key adjustment values to their defaults.

The adjustment values which can be returned to their default values are as follows.

- Adjustment values for the particular key type (Clip, Gain, Density, Filter, etc.)
In the case of chroma keying, all adjustment values return to their default values.
- Key position
- Key inversion
- Clean mode

For details, see “Returning the key adjustment values to their defaults” (page 298).

Key Modify Clear

A simple button operation returns the key settings to the initial status settings.

For details of the initial status, see “Selecting the State After Powering On (Start Up Menu)” in Chapter 16 (Volume 2).

Wipes

A wipe is a transition from the current video stream to a new video stream, using a wipe pattern.

Changing the background by means of a wipe is referred to as a “background wipe,” and inserting or deleting a key with a wipe is termed a “key wipe.”

There are two types of wipe: those that can be selected in a common transition, and those that can be selected in an independent key transition.

For details of independent key transitions, see page 35.

Types of Wipe Pattern

The patterns that can be used for a wipe are divided into a number of groups, as follows. Note that only the standard wipe patterns can be used for an independent key transition.

For wipe patterns, see the appendix “Wipe Pattern List” (Volume 2).

Standard wipe patterns

Patterns consisting of straight lines vertically, horizontally, or diagonally, and circular patterns.

Enhanced wipes

More complex shapes such as hearts, stars, and round corners.

Rotary wipes

These patterns involve rotation of the image about a point.

Mosaic wipe pattern

This divides the image into small tiles.

Random and diamond dust wipe patterns

These patterns consist of small random tiles, or fine particles.

Pattern Mix

You can create a new pattern by combining two selected patterns (main and “sub”).

Note

It is not possible to apply a pattern mix to an independent key transition.

For details, see “Pattern Mix” (page 307).

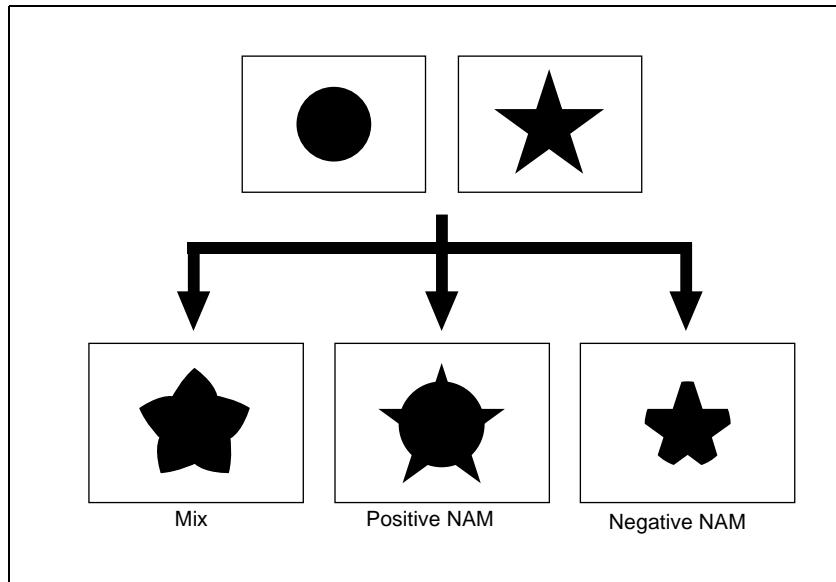
Types of pattern mix

There are four ways in which patterns can be combined in a pattern mix, as follows.

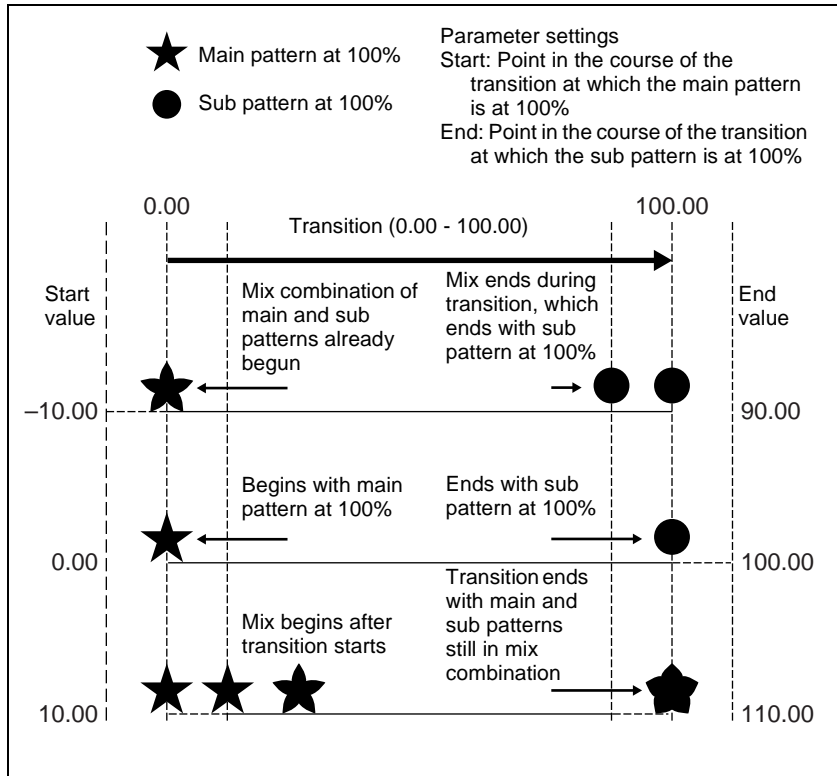
Mix: The effect of the sub pattern is applied to the main pattern, modifying the outline or nature of the main pattern.

Positive NAM (+Nam): Creates a pattern with an outline which contains all points within the outlines of either of the main pattern and the sub pattern.

Negative NAM (-Nam): Creates a pattern with an outline which contains all points within the outlines of both of the main pattern and the sub pattern.



Morphing: As the transition progresses, the pattern morphs from the main pattern, through the “mix” combination, to the sub pattern.



- A value of 0.00 corresponds to the beginning of the transition, and a value of 100.00 to the end of the transition.
- A negative Start value signifies that the main and sub patterns are already combined when the transition starts.
- An End value of 100.00 or more signifies that the main and sub patterns are still combined when the transition complete.
- If the Start and End values are the same, the main and sub patterns are interchanged instantaneously at the corresponding point in the transition.
- If End is less than Start, as the transition proceeds, it changes from the sub pattern to the main pattern.

Dust mix

You can apply the effect of a diamond dust wipe to a selected pattern. You can also apply the diamond dust wipe effect to the pattern resulting from a pattern mix. (See “Pattern Mix” (page 307).)

When the pattern mix function is off, turning dust mix on results in the main pattern and the diamond dust pattern being mixed. This state is the same as a pattern mix when the diamond dust pattern is selected for the sub pattern.

Main and sub modifier link function

When carrying out a pattern mix, it is possible to link the modifier settings for the main pattern and sub pattern. There are two modes for this function.

FULL LINK (fully linked) mode

In this mode, all modifier settings are the same for the main pattern and sub pattern.

Changing the modifier settings for one pattern automatically changes the settings for the other.

SEMI LINK (semi-linked) mode

Only the parameter settings of the modifiers are linked. The modifier on/off settings are not linked. When the parameter values for the modifiers of the main pattern and sub pattern are different, then after this link mode is selected, changing the value of a parameter for one pattern changes the value of the parameter for the other pattern to maintain the same difference between the two.

Note

When carrying out a wipe transition using a pattern mix, it is recommended that you set the modifier link function to “FULL LINK” mode.

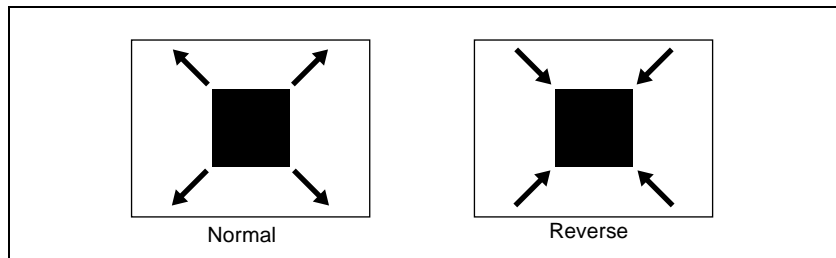
If the link function is off, or SEMI LINK mode is selected, the desired effect may not be obtained at the start or end of the transition.

Wipe Pattern Variation and Modifiers

You can carry out a wipe with the following variations and modifications to the selected pattern. (*For details, see “Setting Wipe Modifiers” (page 309).*)

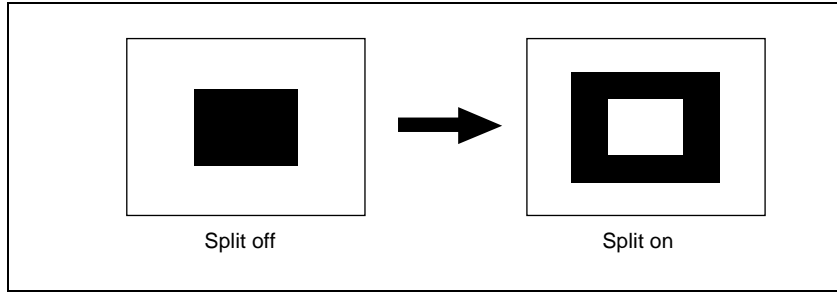
Direction

You can specify the direction of the wipe: the regular direction is referred to as “normal”, and the other direction as “reverse.” You can also select alternating directions each time the transition is completed (normal/reverse mode).



Split

This splits the pattern, making the parts of the wipe move in opposite directions.

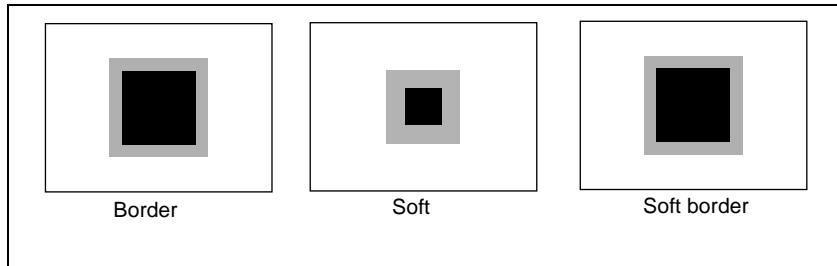


The parameter Split No. specifies the number of splits.
The parameter Spacing specifies the spacing between adjacent patterns.

Edge

You can apply a border to the pattern, soften the edges, or soften the applied border.

In an independent key transition, only the “Soft” setting is available.



Border: You can adjust the border width.

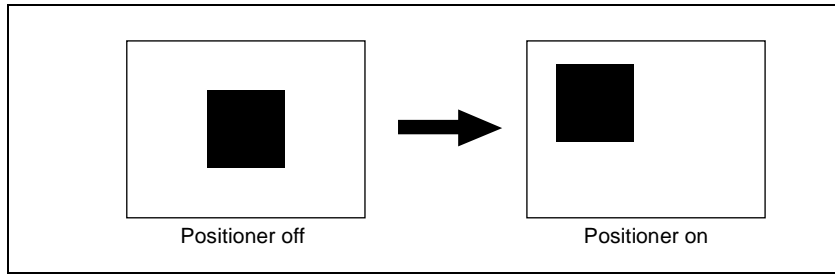
Soft: You can adjust the edge softness.

Soft border: You can adjust the border width, and the softness of the inner and outer edges of the border.

When a border or soft border is selected, the signal filling the border is called edge fill. For the edge fill, you can use a matte generated by the dedicated color matte generator, or the signal selected on the utility 2 bus. A matte can include color 1 and color 2, and a combination of the two colors (a “color mix”).

Positioner

You can move the wipe pattern to any position.



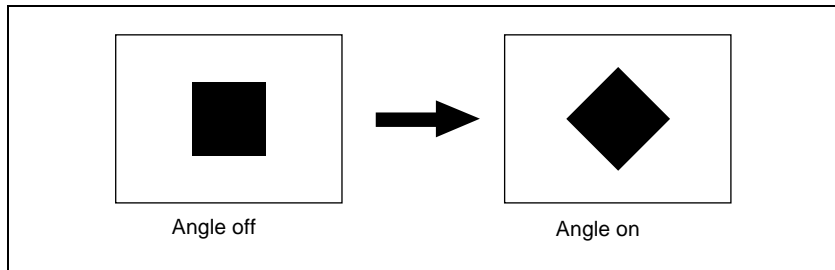
- The parameter **H Position** controls the horizontal position of the pattern. A negative value moves the pattern to the left, and a positive value moves the pattern to the right.
- The parameter **V Position** controls the vertical position of the pattern. A negative value moves the pattern down, and a positive value moves the pattern up.

Rotation

You can rotate the pattern. There are three rotation modes, as follows.

Angle

This carries out a wipe with the pattern in a fixed angle.



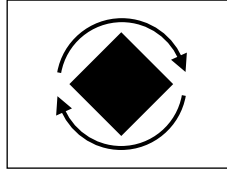
The parameter **Angle** determines the angle of pattern rotation. A value of -100.00 of the parameter **Angle** corresponds to one whole turn counterclockwise; a value of $+100.00$ corresponds to one whole turn clockwise.

With a value of 0.00 there is no rotation.



Speed

Through the course of the transition the wipe pattern rotates at a fixed specified speed.

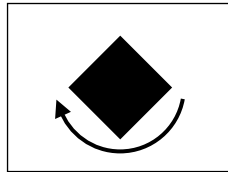


The parameter Speed determines the speed of pattern rotation.

A value of -100.00 of the parameter Speed corresponds to one turn per second counterclockwise; a value of $+100.00$ corresponds to one turn per second clockwise. With a value of 0.00 the pattern is stationary.

Magnitude

Through the course of the transition the wipe pattern rotates through the specified angle.



The parameter Angle determines an angle of pattern inclination at the beginning of the transition.

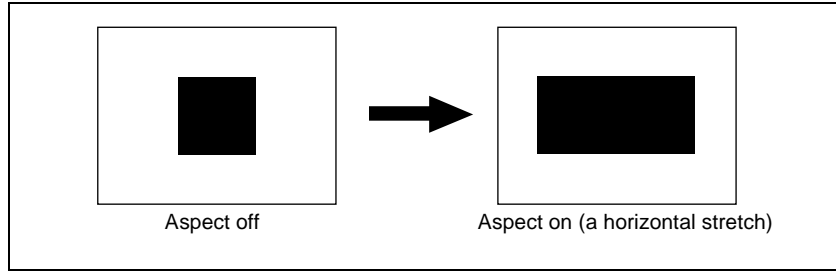
- A value of -100.00 corresponds to the angle rotated one whole turn counterclockwise.
- A value of $+100.00$ corresponds to the angle rotated one whole turn clockwise.
- With a value of 0.00 there is no rotation.

The parameter Magnitude determines an angle of pattern rotation through the course of the transition.

- A value of -200.00 corresponds to a rotation of two turns counterclockwise.
- A value of $+200.00$ corresponds to a rotation of two turns clockwise.
- With a value of 0.00 the pattern is stationary.

Aspect ratio

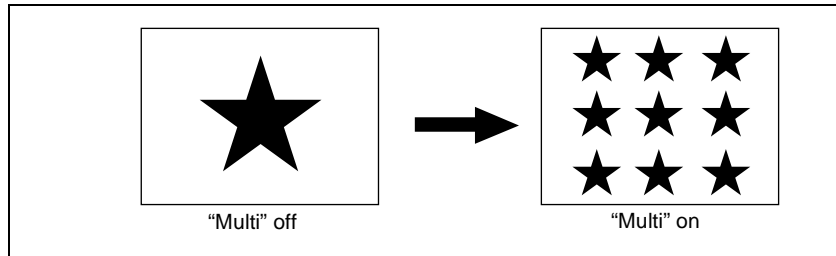
You can freely change the aspect ratio of the pattern.



A negative value of the parameter Aspect stretches the pattern vertically; a positive value stretches the pattern horizontally.

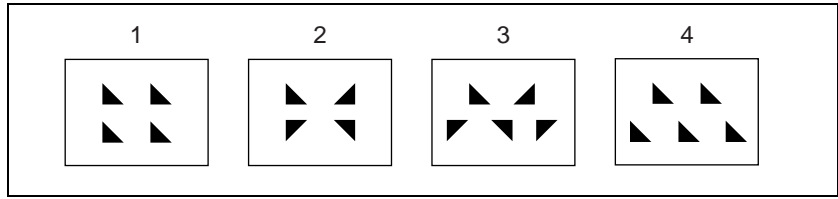
Pattern replication “Multi”

The same pattern can be repeated horizontally and vertically or both, up to 63 times. You can also change the orientation of alternate copies, or change the position.



- The parameter H Multi determines the number of pattern replications horizontally, and the parameter V Multi determines the number of pattern replications vertically.
- The parameter Shift determines the manner of replication.
 At a value of -100.00 , the pattern of the adjacent odd-numbered column on the left lines up with the central coordinate horizontally.
 At a value of $+100.00$, the pattern of the adjacent odd-numbered column on the right lines up with the central coordinate horizontally.

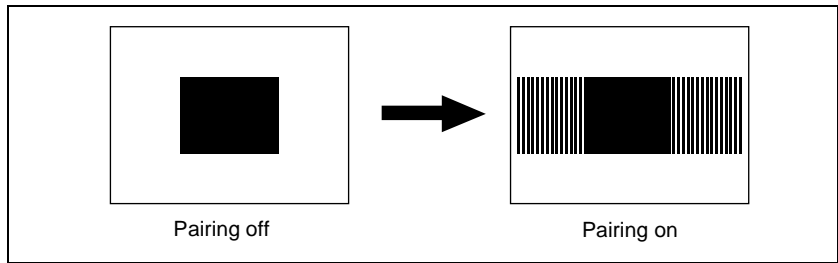
For an independent key transition wipe, you can use the “Invert Type” parameter to select from the following four types of replication pattern.



- 1: All replications in the same orientation
- 2: Even-numbered columns and rows inverted
- 3: Even-numbered columns and rows inverted, and even-numbered rows staggered
- 4: Even-numbered rows staggered

Pairing

This slits the pattern into multiple strips, making it like a venetian blind.



H: Create slits in the horizontal direction.

V: Create slits in the vertical direction.

- The parameter Width determines the width of the slits.
- The parameter H Offset determines the spacing in the horizontal direction. If a negative value is set, the even-numbered pairs of strip and slit move to the left, and the odd-numbered pairs move to the right. The value -100.00 represents the maximum movement. If a positive value is set, the even-numbered pairs of strip and slit move to the right, and the odd-numbered pairs move to the left. The value +100.00 represents the maximum movement.
- The parameter V Offset determines the spacing in the vertical direction. If a negative value is set, the even-numbered pairs of strip and slit move upward, and the odd-numbered pairs move downward. The value -100.00 represents the maximum movement. If a positive value is set, the even-numbered pairs of strip and slit move downward, and the odd-numbered pairs move upward. The value +100.00 represents the maximum movement.

Modulation

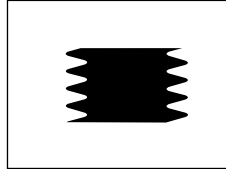
The pattern signal can be modulated, giving waves on the horizontal or vertical edges, or radially.

The parameter Shape determines the form of the modulation.

1: sine wave, 2: triangular wave, 3: rectangular wave

Horizontal modulation

This modulates the pattern, applying waviness in the horizontal direction to edges.

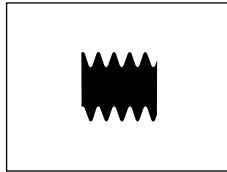


The parameter Speed determines the speed of waves.

A value of -100.00 generates the maximum downward speed of waves, and a value of $+100.00$ the maximum upward speed.

Vertical modulation

This modulates the pattern, applying waviness in the vertical direction to edges.

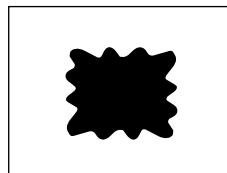


The parameter Speed determines the speed of waves.

A value of -100.00 generates the maximum leftward speed of waves, and a value of $+100.00$ the maximum rightward speed.

Fringe

This modulates the pattern, applying waviness in the radial direction to edges.

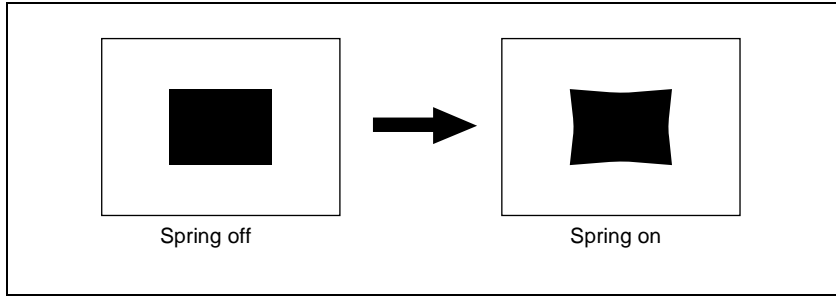




The parameter Speed determines the speed of waves. A value of -100.00 generates the maximum counterclockwise speed of waves, and a value of $+100.00$ the maximum clockwise speed.

Spring

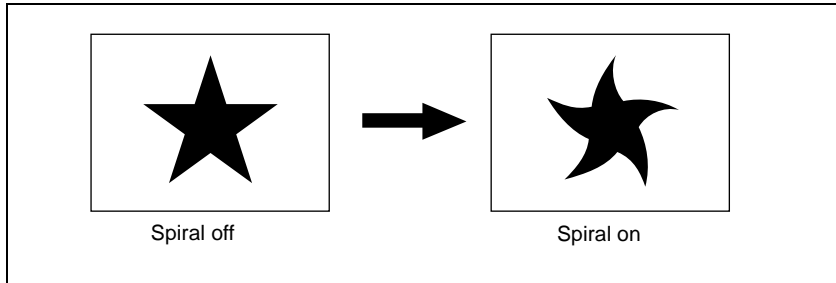
As the transition progresses, the edge of the pattern is subjected to barrel or pincushion distortion.



A negative parameter value produces pincushion distortion, and a positive value produces barrel distortion.

Spiral

This deforms the pattern spirally.



- The parameter Magnitude determines the size and direction of the spiral. A value of -100.00 represents the maximum movement in the counterclockwise direction, and a value of $+100.00$ represents the maximum movement in the clockwise direction.
- The parameter Wave Speed determines the speed of the lateral waves. A value of -100.00 represents the maximum speed to the left, and a value of $+100.00$ represents the maximum speed to the right.



Wipe Snapshots

You can save a wipe pattern and all its associated modifiers, together with the transition rate, instantaneously in a dedicated register, for recall when required. There are 10 wipe snapshot registers on each M/E bank and the PGM/PST bank. Use the Flexi Pad control block in the bank to save and recall wipe snapshots.

For details, see “Wipe Snapshots” (page 327).

For simple transitions (*see page 255*), there are eight wipe snapshot registers on each M/E bank and the PGM/PST bank.

DME Wipes

A DME wipe is a wipe transition that uses a DME effect to change from one video image to the next.

There are two types of DME wipe: those which can be selected for a normal transition, and those which can be selected for an independent key transition.

For independent key transitions, see page 35.

Note

To carry out DME wipes requires the BKDS-9470 DME Board Set.

Types of DME Wipe Pattern

The patterns used for a DME wipe fall into two broad classes.

Preset patterns: predetermined fixed patterns

User programmable DME patterns: patterns which you can create using keyframe effects

DME wipe execution mode and pattern numbers that can be used

There are two DME wipe execution modes, depending on the number of DME channels available: one-channel mode and two-channel mode. The pattern numbers that can be used in these modes are as follows.

Execution mode	Preset pattern numbers available	User programmable DME pattern numbers available
One-channel mode	1xxx	1901 to 1999
Two-channel mode	2xxx	2901 to 2999

DME wipe pattern groups

The patterns used in DME wipes fall into the following groups.

For each group (excluding user programmable DMEs), for schematic patterns and numbers, see the appendix “DME Wipe Pattern List” (Volume 2). The black part of the pattern represents the old video, and the white part the new video, with the wipe taking place in the direction of the arrow.

- Slide:** The new video slides in over the old video.
(Pattern numbers: 1001 to 1008 (one-channel mode), 2601 to 2608 (two-channel mode))
- Split:** The old video splits, and the new video appears in the gap.
(Pattern numbers: 1011 to 1013 (one-channel mode))
- Squeeze:** The new video appears squeezed over the old video, and progressively expands to cover it.
(Pattern numbers: 1021 to 1031 (one-channel mode), 2621 to 2628 (two-channel mode))
- Door:** The new video moves like a door closing, and progressively covers the old video.
(Pattern numbers: 1041 to 1044 (one-channel mode))
- Flip tumble:** The old video rotates about an axis and is replaced by the new video. During the transition, the signal from the utility 2 bus of the M/E bank appears as the background.
(Pattern numbers: 1101 to 1102 (one-channel mode))
- Page turn:** The old video moves like a page turning, and the new video appears behind it.
(Pattern numbers: 1301 to 1313 (one-channel mode))
- Page roll:** The new video unrolls like a scroll over the old video. This is a type of page turn.
(Pattern numbers: 1321 to 1333 (one-channel mode))
- Frame in-out:** Completed in two transitions. In the first transition, the new video appears, then on the second transition the new video goes out and the old video returns.
(Pattern numbers: 1201 to 1204 (one-channel mode))
- Picture-in-picture:** the one-channel mode and two-channel mode differ as follows.
In one-channel mode, this completes in two transitions. In the first transition, the old video shrinks, and the new video appears behind it. In the second transition, the old video expands again until it is its original size.
(Pattern number: 1251 (one-channel mode))
In two-channel mode, in the first half of the transition, the old video shrinks, and the new video appears. In the second half of the transition, the new video expands, and the old video disappears. During the transition, the signal from the utility 2 bus of the M/E bank appears as the background.
(Pattern numbers: 2651 and 2652 (two-channel mode))
- User programmable DME:** Using a DME keyframe effect created with a keyframe operation, this executes a DME wipe.
(Pattern numbers: 1901 to 1999 (one-channel mode), 2901 to 2999 (two-channel mode))

For details of creating keyframe effects, see “Creating User Programmable DME Patterns” (page 342).

Notes

- To use the split, page turn, and page roll effects requires the MKS-8830M Nonlinear Effect Board to be installed in the DVS-9000 system.
- Note that for an independent key transition, only the slide, split, squeeze, door, frame in-out, and user programmable DME patterns are available.

Signals forming part of the background for a DME wipe

In two-channel mode, or flip tumble and so on, in addition to the signals on the A and B buses, a background signal may be visible. This background is normally supplied by the UTIL2 bus signal.

DME Wipe Pattern Variation and Modifiers

You can modify the selected DME wipe pattern in the same way as an ordinary wipe pattern, as follows.

For the setting operations, see “Setting DME Wipe Modifiers” (page 333).

Direction: You can set the DME wipe direction to normal, reverse, or alternating normal/reverse (page 59), except for a key transition, which is always in normal/reverse mode.

Border: You can apply a border or soft border (see page 60), except for DME wipes in the independent key transition control block with which this modifier cannot be used.

In the case of a user programmable DME pattern in which a border has already been applied to the effect, the behavior is as follows.

- When the DME wipe border setting is ON, only part of the border applied in the effect is enabled, and that portion can be adjusted.
- When the DME wipe border setting is OFF, the border applied in the effect is enabled as is.

Positioner: This can only be used when one of the following pattern numbers is selected.

1031, 1201 to 1204, 1251, 2651, 2652

With the progress of the transition, the center of the pattern automatically moves from its initially set position toward the center of the image (see page 61). That is to say, the same effect is obtained as in a normal wipe when the positioner is set to “AUTO CENTER.” Again, by using the position select function, you can move the pattern instantaneously.

Pattern limit: You can restrict the range of the transition as desired. However, this is not available for a DME wipe in the independent key transition control block.

For more details, see “Pattern Limit” (page 239).

Size: This can only be used when one of the following pattern numbers is selected.

1201 to 1204, 1251, 2651, 2652

You can set the size of the image.

Crop: You can crop the image. It is also possible in 16:9 mode to crop both sides, to convert the image to a 4:3 aspect ratio.

Relation Between DME Wipes and Other Effects

The relations between DME wipes and other effects are as follows.

Relation to ordinary wipes

- DME wipes do not use the wipe generator built into the switcher. Therefore, during the execution of a DME wipe, you can still use a pattern produced by the wipe generator as the source for a pattern key or mask.
- A DME wipe pattern cannot be used as the source for a pattern key or mask.

Relation to processed keys

When using the DME for a processed key, if you select a DME wipe, an available DME is automatically allocated to the DME wipe. If all of the DME channels are in use, then it is not possible to select a DME wipe.

Number of DME wipes that can be used simultaneously on a single M/E bank

DME wipes can be used in five places, including the four independent key transitions, but a maximum of two can be used simultaneously.

DME Wipe Snapshots

You can instantaneously save the DME wipe pattern in a special-purpose register, together with all applied modifiers and the transition rate, for recall as required.

There are 10 DME wipe snapshot registers for each of the M/E and P/P banks. To save and recall these registers, use the FlexiPad control block in each switcher bank. (See “DME Wipe Snapshots” (page 341).)
In the case of a simple transition system, there are eight DME wipe snapshot registers for each switcher bank.



Frame Memory

Overview

Frame memory is a function whereby a frame of input video can be frozen and written to memory, for further use as material for editing.

The memory capacity for freeze images is a maximum of 222 frames.

For details of operations, see “Frame Memory Operations” (page 348).

Use of frame memory

There are eight frame memory channels, FM1 to FM8, and each channel independently allows a freeze image to be saved or recalled.

By allocating FM1 to FM8 to cross-point buttons you can use the still image output from each channel as input material. The “still image” refers to a freeze image written to temporary memory or a file saved (stored) in memory.

Correspondence between input and output

There are two buses for capturing frame memory material: the frame memory source 1 bus and the frame memory source 2 bus.

These input buses are used by allocation to one of the pairs of output, FM1&2, FM3&4, FM5&6, and FM7&8. You can freeze a frame in each channel separately, or freeze in the two channels simultaneously.

The source buses allocated to FM1 to FM8 are as follows.

Input	Frame memory source bus 1	Frame memory source bus 2
Output	FM1	FM2
	FM3	FM4
	FM5	FM6
	FM7	FM8

Pair mode

By enabling the pair mode, you can link FM1 and FM2, FM3 and FM4, FM5 and FM6, and FM7 and FM8. For example, when a freeze or image processing is carried out on FM1, the same operation is carried out on FM2. The same applies to the other pairs. When a pair of images are captured in pair mode, the image frozen in FM1 (3, 5, or 7) is referred to as the main file and the other frozen in FM2 (4, 6, or 8) is referred to as the sub file.

Operation modes

The frame memory has the following operation mode.

V/K mode: When the pair mode is active, the key signal is automatically selected on frame memory source bus 2. This is convenient for handling the video and key signals together in frame memory. For example, when you select a video signal on frame memory source bus 1, the key signal assigned to it is automatically selected on frame memory source bus 2. You can also use the signal automatically selected on frame memory source bus 2 as a key signal when processing keyframe memory 1.

To change the pair mode or operation mode, use the Frame Memory menu.

Frame Memory Functions

The frame memory provides the following functions.

- Capturing an image
- Saving an image
- Recalling an image
- Processing an image
- Image output
- Image data management
- Image data transfer

Capturing an image (freeze)

As the input material for the frame memory, you can use the signal selected on the frame memory source bus. For this signal you can use video processing (video levels or hue value adjustment) or masking.

Allocating a frame memory source bus signal to one of FM1 to FM8, then carrying out a freeze captures a still image in the corresponding frame memory output image, and saves it in temporary memory.

For a freeze, an image can be captured either as video frame (a “frame freeze”) or a video field (“field freeze”).

Note

When the system is powered off, any freeze images written to temporary memory are lost.

Saving an image (store)

You can save an image in temporary memory which has been placed with the freeze function as a file in memory. You can save a single image in a single file and apply a name of up to eight characters to the file.

When the system is powered off, the file saved in memory is erased, but you can restore it in the Frame Memory menu. (See “Restoring Files” (page 364).)

Recalling an image

You can recall an image file saved in memory, and allocate to any of the FM1 to FM8 outputs.

Processing an image

You can combine the background image (a still image file allocated to any of FM1 to FM8, a freeze image written to temporary memory, or a black signal) and the input signal.

The following types of processing are available.

Pattern key: Using the signal from a dedicated pattern generator, you can cut out the background image and insert the signal selected on the frame memory source bus or a color matte signal. You can adjust the size and position of the pattern, and add modifiers.

External key: When processing an image in FM1 (3, 5, 7), you can use the signal selected on the frame memory source bus 2 to cut out the background image, and fill with the signal selected on the frame memory source bus 1, or a color matte signal.

When processing an image in FM2 (4, 6, 8), you can use the signal selected on the frame memory source bus 2 to cut out the background image, and fill with a color matte signal (always white).

Note

An external key can only be used when the pair mode is enabled (see page 73).

MIX: Mix the background image with the signal selected on the frame memory source bus or color matte signal. The mix ratio can be set.

NAM: Non-additive mix the background image with the signal selected on the frame memory source bus or color matte signal.

Image output

Moving the output image (reposition function)

For up to two channels of FM1 to FM8 (one from FM1, FM3, FM5 and FM7 and the other from FM2, FM4, FM6 and FM8), you can move the output image



with respect to the screen. The area of the screen around the image that has been moved is filled with black. There are two ways of carrying out this repositioning.

Normal mode: Movement in the horizontal direction is in two-pixel increments.

Black and white mode: Movement in the horizontal direction is in one-pixel increments, and for each pixel moved the color is inverted.

Note

It is not possible to save an image moved with the reposition function directly to frame memory.

Fixing the output image selection (lock function)

For the output of each of FM1 to FM8, this fixes the image at the current output. When this lock is enabled, even if the output is recalled in a snapshot or keyframe, the images output to FM1 to FM8 are preserved.

Image data management

File management

The following operations are possible on files created to hold images.

Delete: Specify a file to be deleted. It is also possible to delete all files simultaneously in a single operation.

Rename file: Change the name of the specified file.

Image data transfer

Files can be transferred between such devices as a hard disk and memory card. In the File menu, files can be saved and recalled.

It is possible to import images such as BMP files or convert frame memory files into a different format and save them in an external device.

For details, see Chapter 17 “Files” (Volume 2).

Notes on transferring multiple still images together

- Transferring all of the still image files within frame memory together fails if the capacity of the memory card is too small to hold all of the images. In this case, replace with a larger capacity memory card, or delete still images until saving is possible.

The relation between memory card capacity and number of images that can be saved is as follows.

Memory card capacity	Number of images that can be saved	
	SD system	HD system
16MB	13	2
32MB	27	5
64MB	55	11
128MB	112	23

Note that when transferring to the hard disk, there is ample capacity, so that problems such as this do not occur.

- If you cancel the operation during a data transfer between frame memory and hard disk or memory card, then an image which was not completely transferred will not be reproducible. Avoid canceling such operations.
- When loading a still image file from hard disk or memory card, if [Freeze Enable] in the Freeze menu is on, the loaded still image file may sometimes be overwritten by the frame memory input image.
To avoid this when loading a file, ensure that [Freeze Enable] is turned off.

Notes on saving or recalling a frame memory still image for or by a snapshot/keyframe

- Storing a frame memory still image for a snapshot or keyframe is simply storing a still image as it is on one of the eight frame memory outputs. Similarly, reproducing a frame memory still image by means of a snapshot or keyframe is simply reproducing a still image as it is on one of the eight frame memory outputs. As concerns as a snapshot or keyframe, settings in the Freeze menu, Composite menu or other menus relating to frame memory have no effect.
- To reproduce a frame memory still image by recalling a snapshot or keyframe, you must have the same still image that was present in the frame memory when you saved the snapshot or keyframe.
Therefore, when saving a snapshot or keyframe using frame memory, you must also save the still image to a storage media such as the hard disk.

Color Backgrounds

The dedicated generators generate color signals, and these can be used as color backgrounds in video effects.

Color background selection

There are two color backgrounds, color background 1 and color background 2, which you use by assigning to cross-point buttons.

Color combinations (“color mix”)

The color generators can output the result of combining two colors, which are color 1 and color 2.

Using a pattern from a dedicated pattern generator, color 1 and color 2 can be combined in the boundary region, forming a color gradation. This is referred to in the menu system as “color mix.”

You can also apply modifiers to the selected pattern.

When the “color mix” function is not used, the result is a flat color, and color 1 is always output.

For details of operations, see “Color Background Setting Operations” (page 368).



Copy and Swap

You can copy and swap the settings among the M/E-1 to M/E-3, and PGM/PST banks or between keyers.

The following settings can be copied or swapped.

- Overall settings for the M/E-1 to M/E-3, and PGM/PST banks
- Keyer settings
- Wipe settings in a transition control block
- Wipe settings in an independent key transition control block
- DME wipe settings in a transition control block
- DME wipe settings in an independent key transition control block
- Matte data (color 1, color 2, and how to compose them)
- Color settings
- DME channel settings

You can carry out copy operations with a simple button operation. Swap operations, and copy operations on DME data can only be done with a menu operation.

Note

To carry out DME operations requires the BKDS-9470 DME Board Set.

For details of the operations, see Chapter 9 “Copy and Swap” (page 371).

M/E copy and M/E swap

You can copy and swap the overall bank settings among the M/E-1 to M/E-3, and PGM/PST banks.

Target bank	Target data
M/E-1 M/E-2 M/E-3 PGM/PST	Bank settings excluding the following data items: <ul style="list-style-type: none"> • Setup data • Flexi Pad settings • Snapshots • Keyframe effects • Key snapshots • Key memory

Note

If a DME is being used on the source M/E bank, then if for example there are insufficient DME channels, it may not be possible to select the DME.

There are no such restrictions on a swap.

Keyer copy and keyer swap

You can carry out copy and swap operations among the 16 keyers listed in the following table.

Target bank	Target keyer	Target data
M/E-1 M/E-2 M/E-3	Keys 1 to 4	Key settings excluding the following data items: <ul style="list-style-type: none">• Setup data• Key snapshots• Key memory
PGM/PST	Downstream keys 1 to 4	

Note

If a DME is being used on the source keyer for a copy or either keyer for a swap, then if for example there are insufficient DME channels, or the limit on using DME channels within an M/E bank is exceeded, it may not be possible to select the DME.

Wipe copy and wipe swap

You can copy and swap the wipe settings among the banks listed in the following table.

Target bank	Target data
M/E-1 M/E-2 M/E-3 PGM/PST	Wipe settings. It is not, however, possible to carry out copy or swap involving independent key transition wipe settings.

Wipe copy and wipe swap in the independent key transition control block

You can copy and swap the wipe settings among the 16 keyers listed in the following table.

Target bank	Target keyer	Target data
M/E-1 M/E-2 M/E-3	Keys 1 to 4	Wipe settings in the independent key transition control block.
PGM/PST	Downstream keys 1 to 4	It is not, however, possible to copy or swap wipe settings to or from an external downstream keyer.

DME wipe copy and DME wipe swap

You can copy and swap the DME wipe settings among the M/E-1 to M/E-3, and PGM/PST banks.

Target bank	Target data
M/E-1 M/E-2 M/E-3 PGM/PST	DME wipe settings. It is not, however, possible to carry out copy or swap involving independent key transition DME wipe settings.

DME wipe copy and DME wipe swap in the independent key transition control block

You can copy and swap the DME wipe settings among the 16 keyers listed in the following table.

Target bank	Target keyer	Target data
M/E-1 M/E-2 M/E-3	Keys 1 to 4	DME wipe settings in the independent key transition control block.
PGM/PST	Downstream keys 1 to 4	

Matte data copy and swap

You can copy or swap the matte data among the 38 color generators listed in the following table.

Target bank	Target keyer and data	
M/E-1 M/E-2 M/E-3 PGM/PST	<ul style="list-style-type: none"> Keys 1 to 4 Downstream keys 1 to 4 	<ul style="list-style-type: none"> Matte data for key fill Matte data for key edge fill
	Matte data for wipe border edge	
Color background	<ul style="list-style-type: none"> Matte data for color background 1 Matte data for color background 2 	

Color data copy and swap

You can copy or swap the color data among the 152 color generators listed in the following table.

Target bank	Target keyer and data	
M/E-1 M/E-2 M/E-3 PGM/PST	<ul style="list-style-type: none"> Keys 1 to 4 Downstream keys 1 to 4 	<ul style="list-style-type: none"> Colors 1 and 2 for key fill Colors 1 and 2 for key edge fill "Zabton" color data
	Colors 1 and 2 for wipe border	
	Color data for preset color mix	
Color background	<ul style="list-style-type: none"> Colors 1 and 2 for color background 1 Colors 1 and 2 for color background 2 	
Frame memory	<ul style="list-style-type: none"> FM1 color FM2 color 	



Target bank	Target keyer and data
DME ch1 to ch4	<ul style="list-style-type: none">• Background• Border• Sepia• Light• Shade• Drop shadow (other than DME ch4)• Trail

DME channel copy and swap

You can copy and swap the channel data among DME channels 1 to 4.

Video Process

The term “video process” is applied to adjustments to the luminance and hue of the input video signal.

There are two types of adjustment, depending on the application:

- Adjustment of an individual primary input signal
- Image effects on a particular bus

Note

These types of adjustment may be carried out independently. However, since they are implemented by the same hardware, if the same signal is subjected to processing twice, there may be limitations on the range of effects obtained in the final result.

Video Process Adjustment of a Primary Input Signal

For each of primary inputs 1 to 80, you can switch video process adjustments on or off, and can adjust the parameters (Video Gain, Y Gain, C Gain, Hue Delay, and Black Level) in the Setup menu. The adjustments do not, however, apply to the output video on the MON (monitor) bus.

For details of the settings, see “Signal Input Settings” in Chapter 16 (Volume 2).

Video Process Adjustments on a Particular Bus

Buses to which the adjustments apply

For each of the following buses, you can switch video process adjustments on or off, and adjust the parameters.

- Following buses in the M/E-1 to M/E-3, and PGM/PST banks
 - Key fill buses for keys 1 to 4
 - Background A and background B buses
 - Utility 1 and utility 2 buses
- Frame memory source 1 and frame memory source 2 buses
- Aux 1 to 48 buses

These settings also apply to keyframes and snapshots.

**Making the adjustments**

Adjust VIDEO GAIN, Y GAIN, BLACK LEVEL, C GAIN, and HUE DELAY in the following menus.

Applicable bus		Menu used for operation	See page
M/E-1 to M/E-3 banks	Key fill buses for keys 1 to 4	M/E-1 to M/E-3 menus	page 286
	background A and B buses	Video Process menu	page 379
	Utility 1 and 2 buses		
PGM/PST bank	Key fill buses for DSK1 to DSK4	PGM/PST menu	page 286
	Background A and B buses	Video Process menu	page 379
	Utility 1 and 2 buses		
Frame memory source 1 and 2 buses		Frame Memory menu	page 353
Aux 1 to 48 buses		AUX/MON menu	page 378

Video Process Memory

When using video process adjustments for an image effect on a bus, this function saves the final values for each pair number for the signals. The video process on/off setting is not saved.

When you change the adjustments the values are automatically saved, and these last values are recalled when the pair number is selected.

In other words, by switching video process memory on, regardless of the video process information for each bus, you can carry out video process adjustments for each input signal.

The parameters saved are as follows.

VIDEO GAIN, Y GAIN, BLACK LEVEL, C GAIN, HUE DELAY

Switch the video process memory on or off in the Setup menu.

For details of setting operations, see “Settings Relating to Keys, Wipes and Frame Memory (Key/Wipe/FM Menu)” in Chapter 16 (Volume 2).

Digital Multi Effects (DME)

DME allows you to add three-dimensional effects such as image movement, rotation, magnification and shrinking, as well as a wide variety of special effects. DME is the general name for all of these effects.

You can use up to four channels as dedicated DME channels. Each channel can be used on its own or in combination with other channels, which allows you to create advanced effects with more complexity.

Note

To carry out DME wipes requires the BKDS-9470 DME Board Set.

Three-Dimensional Transformations

Transformation is the process of placing a video image in a three-dimensional DME coordinate space and subjecting it to manipulations such as movement, rotation, magnification or shrinking.

Three-dimensional coordinate space

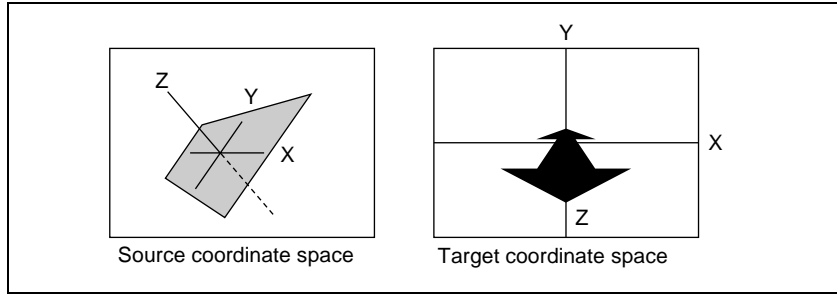
Source coordinate space and target coordinate space

Images are placed in one of two types of coordinate space: source coordinate space and target coordinate space.

- The source coordinate space is a three-dimensional coordinate space with reference to the image itself. The x- and y-axes are defined parallel to the plane of the image, and the z-axis is defined perpendicular to the plane of the image. When you move the image, the coordinate axes also move.
- The target coordinate space is a three-dimensional coordinate space with reference to the output monitor screen. The x- and y-axes are defined parallel to the plane of the monitor screen, and the z-axis is defined perpendicular to

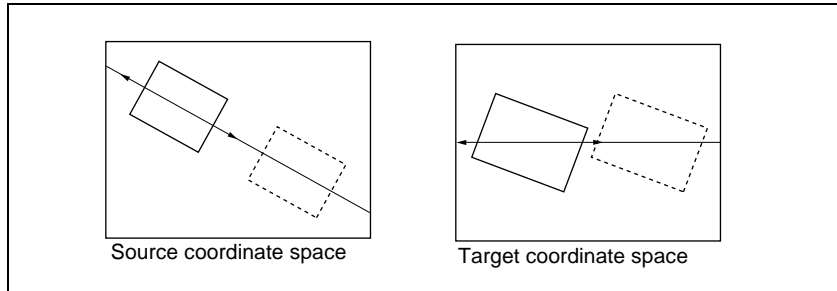


the plane of the monitor screen. The coordinates do not move even if the image moves.



Source coordinate space and target coordinate space

For example, as shown below, the image moves in a different direction when you move it along the x-axis of the source coordinate space and along the x-axis of the target coordinate space.

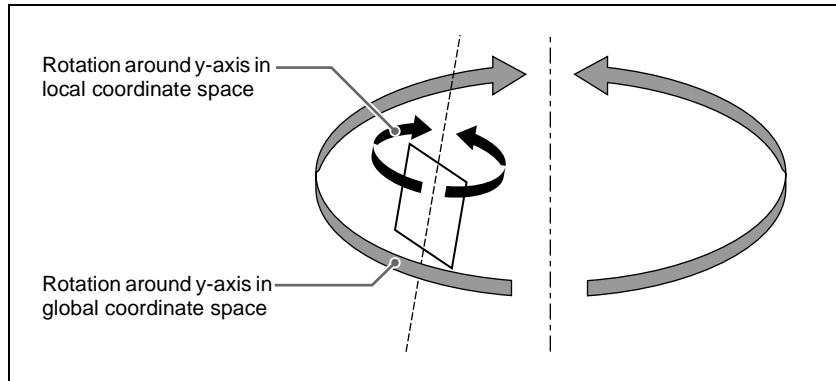


Movement along the x-axes of the source coordinate space and target coordinate space

Local coordinate space and global coordinate space

The coordinates of an individual DME channel are called its local coordinate space. The coordinates common to all channels are called the global coordinate space.

By switching from local to global coordinate space, you can add new movement to the movement of images in individual channels, and also apply transformation effects to multiple channels that have been combined by Global effects (page 113).



Local coordinate space and global coordinate space

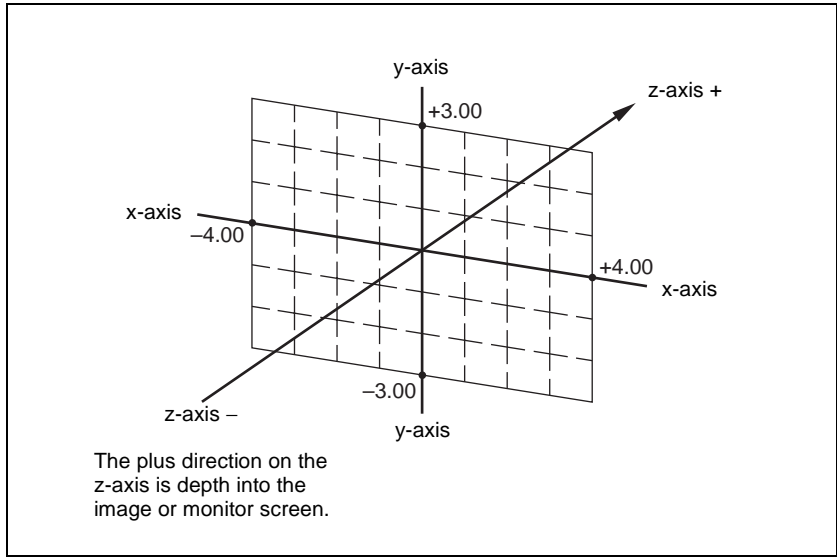
Three-dimensional parameters

Three-dimensional parameters are x , y , and z values which define the position of an image, its axis of rotation, the position of an imaginary point of view on the image, and so on.

The standard values of parameters are as shown below, depending on the aspect ratio of your monitor (4:3 or 16:9).

Values for 4:3 mode

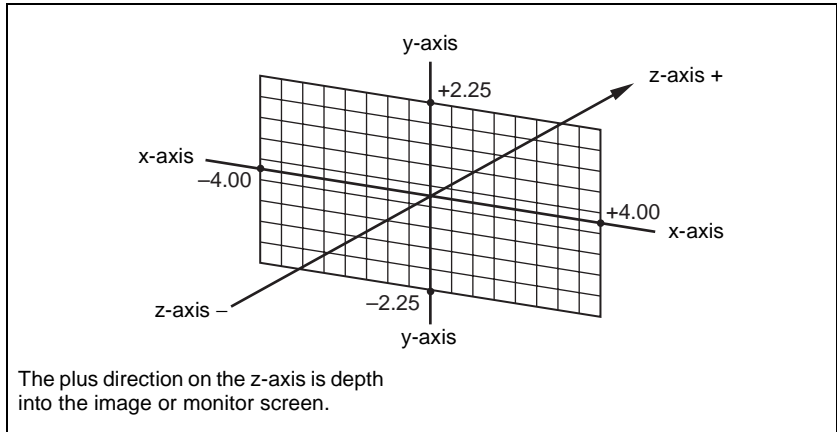
- **Origin at center of image (source coordinate space) or center of monitor (target coordinate space)**
 $x = 0.00, y = 0.00, z = 0.00$
- **Upper right corner of image or monitor**
 $x = 4.00, y = 3.00, z = 0.00$
- **Lower left corner of image or monitor**
 $x = -4.00, y = -3.00, z = 0.00$



Values for x-, y-, and z-axes (4:3 mode)

Values for 16:9 mode

- **Origin at center of image (source coordinate space) or center of monitor (target coordinate space)**
 $x = 0.00, y = 0.00, z = 0.00$
- **Upper right corner of image or monitor**
 $x = 4.00, y = 2.25, z = 0.00$
- **Lower left corner of image or monitor**
 $x = -4.00, y = -2.25, z = 0.00$



Values for x-, y- and z-axes (16:9 mode)

Limits of three-dimensional parameters

The following table shows the limits of three-dimensional transformation parameters.

The three-dimensional parameters of an image change when you use the trackball or Z-ring to execute a transformation. You can also execute a transformation by entering parameter values from the numeric keypad control block.

Operation mode	Limits of three-dimensional transformation parameters
Location XYZ	-333.3333 to +333.3333
Rotation, Spin	-999.9999 to +999.9999
Axis Location	-333.3333 to +333.3333
Location Size	0.0000 to +999.9999
Aspect	0.0000 to +2.0000
Perspective (x, y) Perspective (z)	-333.3333 to +333.3333 0.0000 to 999.9999
Skew	-3.3333 to +3.3333

Detents

The system defines points called detents at regular intervals on the three-dimensional space. Pressing the [CTR] button in the device control block sets the current three-dimensional parameter values to the closest detent points. (For details, see “Three-Dimensional Transformation Operations” in Chapter 11 (Volume 2).)

The following table shows the interval between successive detents for each transformation operation mode (see page 90).

Operation mode	Detent interval
Location XYZ	1.00
Rotation, Spin	0.25
Axis Location	1.00
Location Size	0.25
Aspect	1.00 ^{a)}
Perspective (x, y) Perspective (z)	1.00 1.00 ^{a)}
Skew	0.10

a) When a value is smaller than 1, 1/Aspect or 1/Perspective (z) is adjusted to an integral value.

Three-dimensional parameter default values

Each of the transformation operation modes has default values for three-dimensional parameters. If required, you can return the current value to the defaults by pressing the [CTR] button in the device control block twice in rapid succession. (For details, see “Three-Dimensional Transformation Operations” in Chapter 11 (Volume 2).)

The following table shows the default parameter values for each transformation operation mode.

Operation mode	Default value
Location XYZ	0.00
Rotation, Spin	0.00
Axis Location	0.00
Location Size	1.00
Aspect	1.00
Perspective (x, y)	0.00
Perspective (z)	1.00
Skew	0.00

Resetting of parameter values set in the source coordinate space

In some transformation operation modes, if you switch to the target coordinate space after setting up a three-dimensional transformation in the source coordinate space, the setting values in the source coordinate space (three-dimensional parameter values) are converted to values in the target coordinate space (source/target conversion).

Once a conversion has taken place, the original source coordinate space parameters do not return to their original values when you switch back to the source coordinate space. They are reset to zeros.

Source/target conversion occurs in the following operation modes:

- Location XYZ
- Rotation

Transformation Operation Modes

The following operation modes are available for three-dimensional DME transformations. These operations are carried out in the device control block. (For details, see “Three-Dimensional Transformation Operations” in Chapter 11 (Volume 2).)

Location XYZ

Moves the image on the x-axis, y-axis, or z-axis. The direction of movement differs depending on whether you are manipulating the image in the source coordinate space or the target coordinate space.

Image movement in the source coordinate space

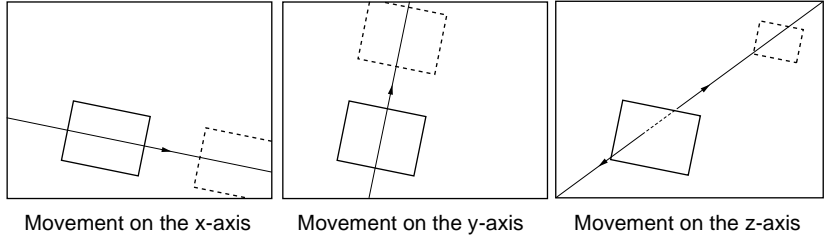
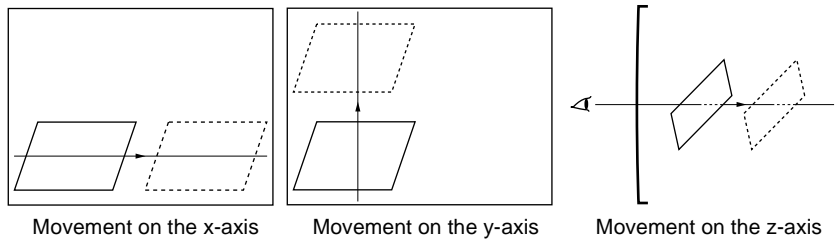


Image movement in the target coordinate space

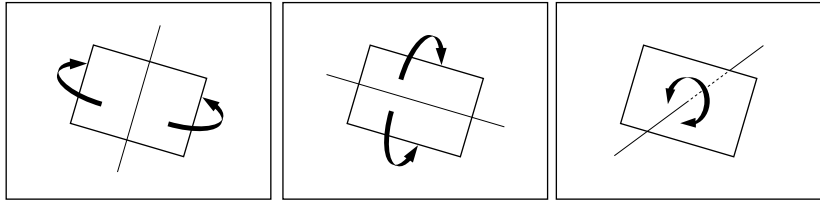


Rotation

Rotates the image on the x-axis, y-axis, or z-axis. The type of rotation differs depending on whether you are manipulating the image in the source coordinate space or the target coordinate space.

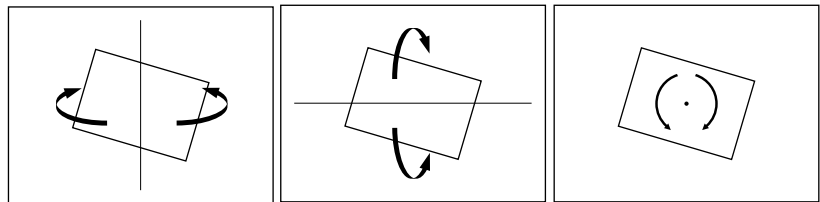


Image rotation in the source coordinate space



Rotation around the y-axis Rotation around the x-axis Rotation around the z-axis

Image rotation in the target coordinate space



Rotation around the y-axis Rotation around the x-axis Rotation around the z-axis

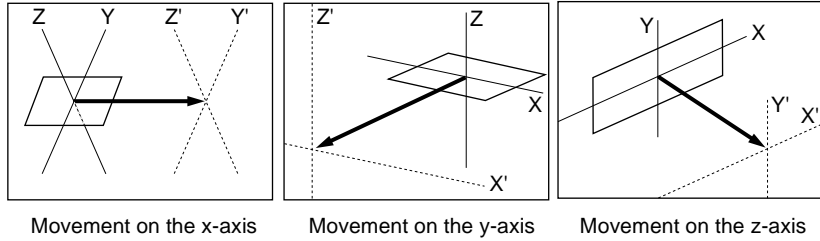
Spin

When rotating the image in Rotation mode, it may not always be possible to achieve the kind of rotation around an axis that you want. Combining Rotation mode with Spin mode creates an effect that rotates the image around a specified axis. The type of rotation differs depending on whether you are manipulating the image in the source coordinate space or the target coordinate space. (The way the image rotates around an axis is the same as in Rotation mode.)

Axis Location

Moves an axis of rotation in the source coordinate space.

Axis movement

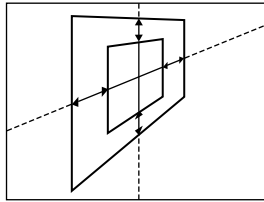


Location Size

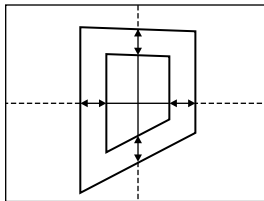
Changes the size of the whole image.

- Because shrinking and magnification of the image in the source coordinate space is done in three-dimensional space, magnifying the image emphasizes the sense of perspective.
- Because shrinking and magnification of the image in the target coordinate space is a conversion of the two-dimensional image displayed on the monitor, shrinking and magnification does not change the shape of the image.

Magnification and shrinking in the source coordinate space

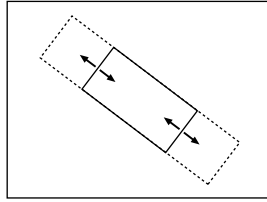


Magnification and shrinking in the target coordinate space

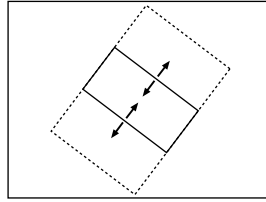


Aspect

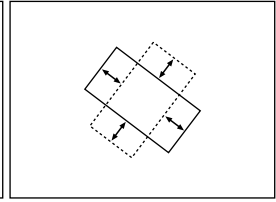
In the source coordinate space, changes the aspect ratio in the x-direction and y-direction, either independently or simultaneously.



Change of aspect ratio in x-direction



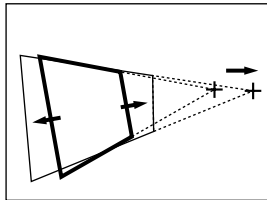
Change of aspect ratio in y-direction



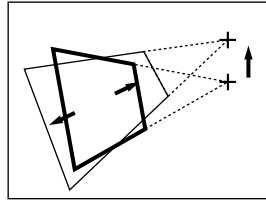
Simultaneous change aspect ratio in x-direction and y-direction

Perspective

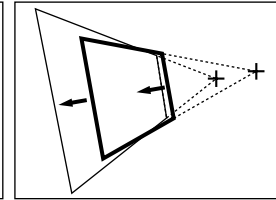
In the target coordinate space, changes the perspective on the image by changing an imaginary view point, without changing the position of the image. The x-axis and y-axis values define the position of the view point. The z-axis value defines its distance from the image.



Change of view point on x-axis



Change of view point on y-axis

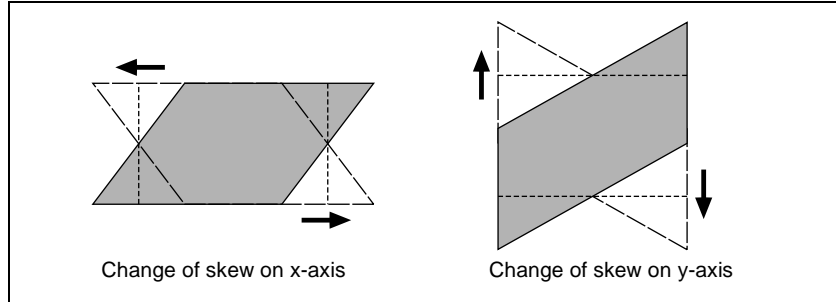


Change of distance from view point to image



Skew

In the source coordinate space, change the skew of the image on the x-axis or y-axis.



Graphics Display

Graphics display is a function that allows you to display wire frames, coordinate axes and a grid over the current DME image, to make it easier to create effects in three-dimensional coordinate space.

To make graphics display settings, use the DME menu. (*For details, see “Graphics Display” in Chapter 11 (Volume 2).*)

You can display the following kinds of graphics.

Wire frames

A wire frame displays an image enclosed in a frame, so that you can check the position and size of the image. If there is a shadow (*see page 116*), a frame is shown for the shadow as well.

Coordinate axes

This is a three-dimensional display of coordinates in local or global coordinate space. You can check the origin of the axes and the directions of the x-, y-, and z-axes.

Channel ID

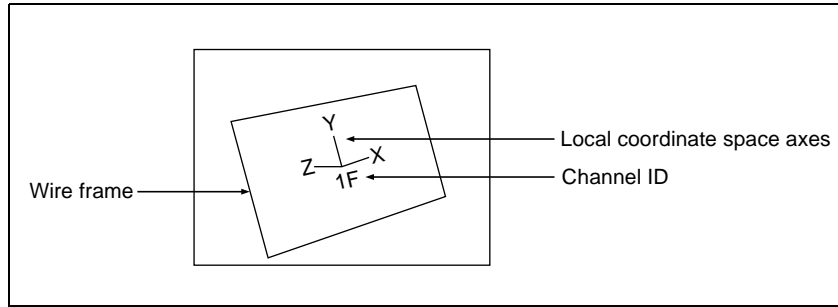
This displays the channel number so that you can check which channel you are using, a useful feature when you are working with multiple channels.

Channel IDs are displayed differently in local and global coordinate space.

- In local coordinate space, the channel number is displayed along with “F” or “B” to indicate whether you are looking at the front (F) or back (B) of the current wire frame. For example, “1F” means the front of the wire frame on channel 1 in local coordinate space.



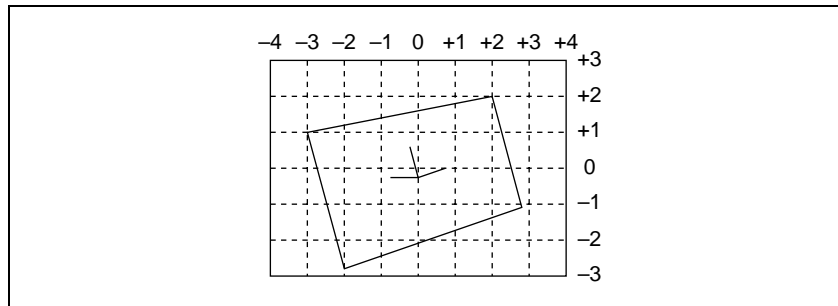
- In global coordinate space, the channel number is displayed along with “G” to indicate global. For example, “G2” means channel 2 in global coordinate space.



Wire frame, local coordinate space axes, and channel ID

Grid

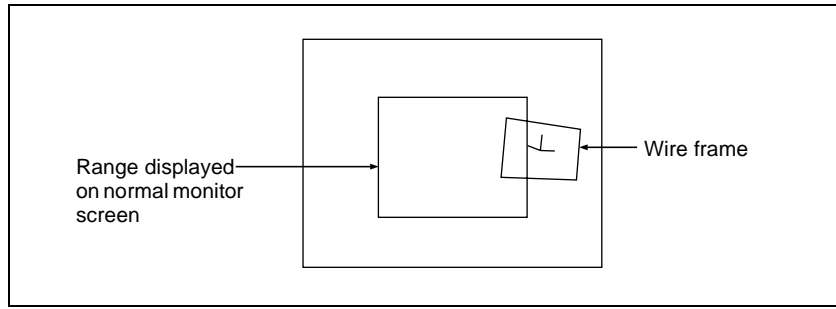
This is a grid pattern representing the whole of the monitor screen. The grid makes it easy to set the position of an image in two-dimensional coordinates.



Grid (4:3 mode)

Shrinking the graphics display

You can shrink the graphics display so that you can see beyond the range displayed on the normal monitor screen. This makes it possible to visually set the location of images in a larger space. The range displayed on a normal monitor screen is indicated by a frame.



To automatically erase the graphic display

Turn Auto Erase on. The graphic display is erased automatically whenever a keyframe is executed. It is displayed again after the keyframe ends, after the time set in Recovery Time.

Three-Dimensional Parameter Display

You can display a three-dimensional parameter list for the currently controlled image. When more than one DME channel is selected, the status of the reference channel is displayed.

For the method of displaying a parameter list and an example display, see “Three-Dimensional Parameter Display” in Chapter 11 (Volume 2).

DME Special Effects

You can use DME to add a variety of special effects. To add effects, use the DME menu. (See “DME Special Effect Operations” in Chapter 11 (Volume 2).)

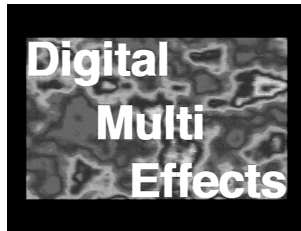
Border

This effect adds a border to the image frame. You can adjust the width (or thickness) of the border, its color, and the softness of the border edges.



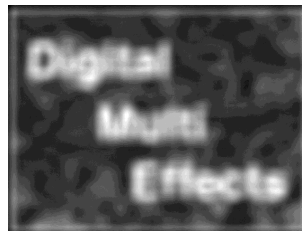
Crop

This effect crops away the edges of the image. You can crop the top, bottom, left, and right sides individually or all together. You can also soften the cropped edges.



Defocus

Defocuses the whole image. The degree of defocusing can be set separately for video signals and key signals. You can also cancel the black level leaking that occurs at the edge of the screen when the Defocus effect is used.

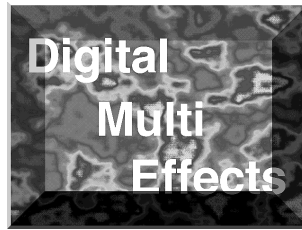


Blur

Applies a rounded blurring to the whole image.

Beveled Edge

This gives an image a beveled edge. You can set the edge width and color. The inner edge softness and edge boundary softness can also be set.



Light



Color

Multi Move

Shrinks the image and lines up a number of copies vertically and horizontally. You can specify the center point of the shrinking, the shrinking ratio, and the aspect ratio of the image screen.



Sepia

Overlays a specified color onto the image. You can adjust the sepia color that is overlaid, and specify the degree of mixing between the original image and the sepia image.

Mono

Converts the image into a monochrome image.

Posterization

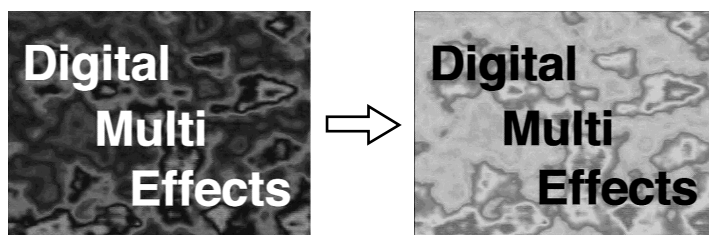
Coarsens the luminance gradations of the image, for a painting-like effect. You can specify the degree of luminance coarsening.

Solarization

Like the Posterization effect, creates a painting-like effect, but does so by coarsening the chroma gradations of the image. You can specify the degree of chroma coarsening.

Nega

Reverses the luminance and/or chroma of the image.

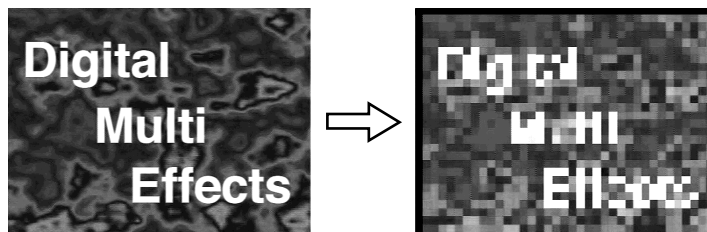


Contrast

Changes the contrast of the luminance and/or chroma of the image.

Mosaic

Divides the image into small tiles so that it looks like a mosaic. You can specify the size and aspect ratio of the tiles.



Freeze

Freezes the input video. The following types are available:



Hard Freeze: Freezes the input video at an arbitrary timing.

Time Strobe: Freezes the input video at specified intervals for a specified length.

Film: Slows the apparent frame rate, for an effect like film. You can specify the ratio of advancement.

For Hard Freeze and Time Strobe, you can select the first field or the frame as the freeze timing.

Nonlinear Effects

You can add a variety of effects, including effects that change the shape of the image as a whole.

The following nonlinear effects are available.

For more information about settings and operations with nonlinear effects, see “Nonlinear Effect Settings” in Chapter 11 (Volume 2).

Note

It is not possible to apply two or more nonlinear effects at the same time. Turning any nonlinear effect on automatically turns all other nonlinear effects off.

Wave

Produces a wave-like effect in the image.

There are two modes: H&V and Size. You can set the size and frequency of the waves, the wave form, the amount of wave movement, and the range. In H&V mode, you can also set the wave angle.



Mosaic Glass

Makes the image rougher and finer at a specified interval.

There are two modes: H&V and Size. You can set the size and frequency of waves in the image, the wave form, the amount of wave movement, and the range. In H&V mode, you can also set the wave angle.



Flag

Applies an effect like a flag waving in the wind.

There are two modes: H&V and Size. You can set the size and frequency of waves in the image, the wave form, the amount of wave movement, and the range. In H&V mode, you can also set the wave angle.

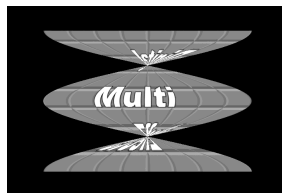


Twist

Twists the image.

You can twist the image in the horizontal or vertical direction.

You can set the size and frequency of waves in the image, the wave form, the amount of wave movement, and other parameters.



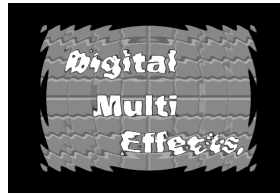
Ripple

Applies an effect like ripples moving across the image.

There are four modes: Radial, Angular, Both, and Shape. The direction of modulation differs depending on the mode. You can set the size and frequency of the ripples, their direction and speed, their center point, and other

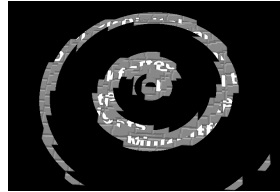


parameters. In Shape mode, you can select ripple shapes other than circles (stars, etc.).



Rings

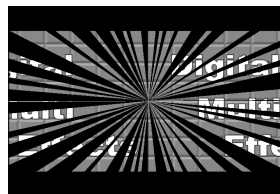
Partitions the image into rings that rotate while moving in the same direction. You can set the degree of transition, the degree of randomness in the distance moved by each block, the amount of movement, the width of the partitions, the degree of randomness in partition width, the center point, the starting angle, and other parameters.



Broken Glass

Partitions the image like broken glass, with shards flying outward. You can set the degree of transition, the degree of randomness in the distance moved by each block, the amount of movement, the width of the partitions, the degree of randomness in partition width, the center point, the starting angle, and other parameters.

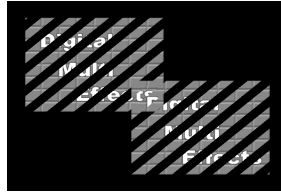
You can also fix the direction in which shards scatter.



Flying Bar

Divides the image into bars which peel off in two blocks as they move.

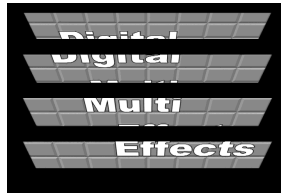
You can set the degree of transition, the degree of randomness in the distance moved by each block, the direction of movement, the width of the partitions, the degree of randomness in partition width, the partition angle, and other parameters.



Blind

Divides the image into bars or wedges, with blocks rotating like the slats of venetian blinds.

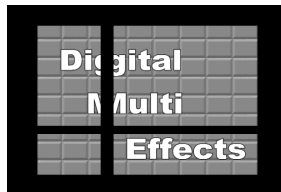
There are two modes: Bar and Wedge. You can set the number of rotations by blocks, the perspective, the width and position of blocks, the direction, the center position, and other parameters.



Split

Splits the image upper and lower, left and right.

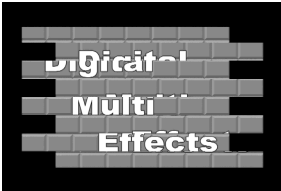
You can set the degree to which the image is split, the split positions, and other parameters.



Split Slide

Divides the image into bars which slide alternately in reverse directions.

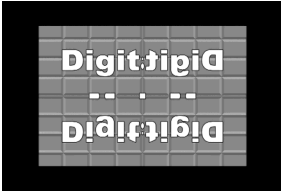
You can set the degree of transition, the degree of randomness in the distance moved by each block, the degree of sliding, block width, block angle, and other parameters.



Mirror

Partitions the image vertically and horizontally, creating an image like a reflection in a mirror.

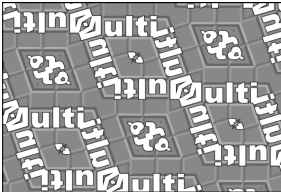
You can choose to reflect in the directions left to right, right to left, bottom to top, top to bottom, or any combination of directions. You can also set the position of the border between original and reflections.



Multi Mirror

Divides the image into originals and reflections, lining them up vertically and horizontally.

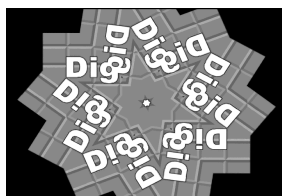
You can set the width of the original, the center position of the original, the offset of the image with fixed mirrors, the direction of the mirrors, and other parameters.



Kaleidoscope

Creates an image like a view into a kaleidoscope.

You can set the number of blocks, the partition reference point and angle, horizontal and vertical offsets, a reflection position, and other parameters.



Lens

Creates an image like a view through a lens.

You can set the shape and aspect ratio of the lens, the angle, the magnification ratio, the curve ratio, the size, the center position, and other parameters.

You can also choose to display only the portion of the image that is seen through the lens.



Circle

Makes a circle with the image.

You can set the size of the circle, and make the axis of modulation vertical.

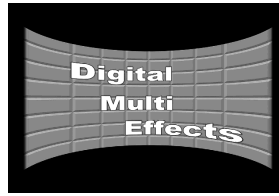


Panorama

Curves the upper and lower edges of the image to emphasize the sense of perspective.



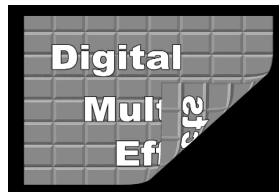
You can set the horizontal and vertical curve ratio, and the curve center position.



Page Turn

Turns the image like a turning page.

There are four modes: H&V, H, V, and Off. You can select the turn position, the radius of the turned portion, the amount and angle of turning, and the input video for the front and back pages.



Roll

Rolls the image up.

There are four modes: H&V, H, V, and Off. You can select the turn position, the radius of the turned portion, the amount and angle of turning, and the input video for the front and back pages.



Cylinder

Winds the whole image onto a cylinder.

You can set the degree of winding onto the cylinder, the radius, the horizontal position of the wound image, and front and back side output for the image.



Sphere

Winds the whole image onto a sphere.

You can set the degree of winding onto the sphere, the radius, the horizontal position of the wound image, and front and back side output for the image.



Note

You cannot monitor the part of a rotating sphere that corresponds to its axis on the monitor screen.

Explosion

Divides the image into fragments which expand as they fly out.

You can set the pattern shape and aspect ratio, the center position, the amount of movement by fragments, the curvature of the transition path, and other parameters.

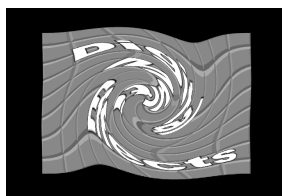


Swirl

Swirls the image.



You can set the amount of swirl, the swirl region, the amount of rotation, and the swirl center position.



Melt

Melts the image away from a specified part.

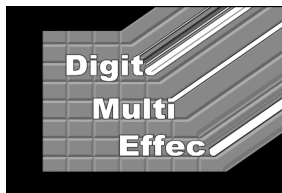
You can set the degree of transition, the degree of extension in the image, the jaggedness of the melting sections, and the amplitude, frequency, amount of movement, and speed of the melting sections. You can also set the slant of the borders, the shape of the sections that begin to melt, and other parameters.



Character Trail

Extends the edge of the image like a trail.

You can set the effect starting position, the degree of expansion, the slant angle of the effect region, and trail direction, the degree to which the image disappears, the trail type and amount of stardust, and other parameters.



Lighting

Provides the effect of light striking the image. You can specify the intensity and color of the light and the lighting pattern. The following lighting patterns are available:



Plane: Illumination of the entire screen.

Bar: Bar illumination. You can specify the width and angle of the bar, and its softness.

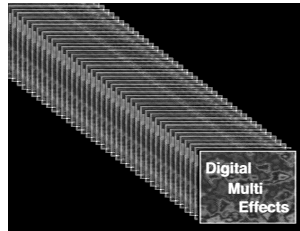
Preset: Lighting pattern suitable for nonlinear effects.

Trail

Recursively freezes the input video at regular intervals so that a trail of afterimages is created. You can make the afterimages stardust trails.

Note

Of the three effects of trail, motion decay and keyframe strobe, only one can be on at a time. When one of them is on, turning another of them on automatically turns off the one that has been on.



Motion Decay

Blurs the motion of a moving video by creating afterimages of the moving video. (See “Note” in the preceding section “Trail.”)
You can make the afterimages stardust trails.



Keyframe Strobe

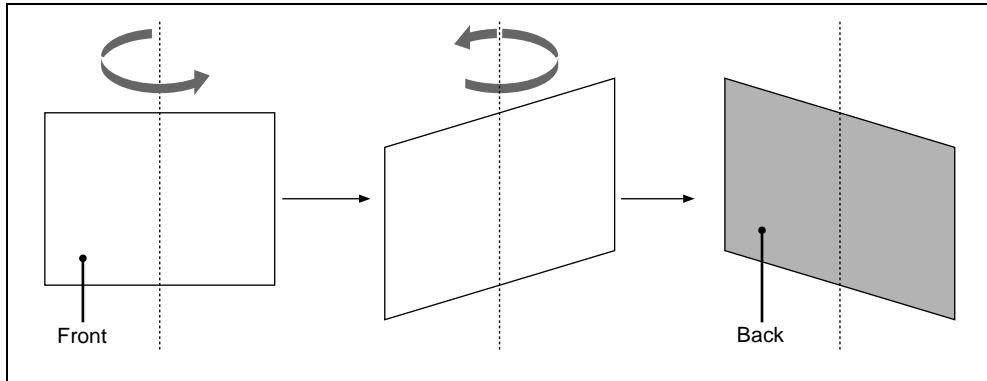
Freezes the video each time the effect passes a keyframe. (See “Note” in the preceding section “Trail.”)
You can make the afterimages stardust trails.

Background

Adds a color to the background of the image.

Separate Sides

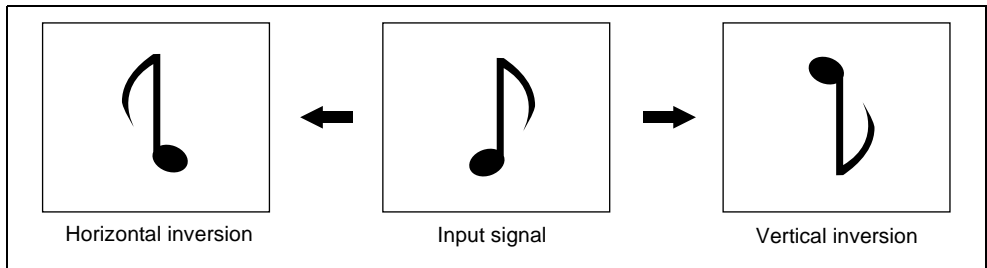
Applies separate video signals and key signals to the front and back of the image.



Front and back sides

Invert

Inverts the input video signal and/or key signal horizontally or vertically. You can make separate settings for the front and back.



Inversion of input signal

Interpolation

Specifies the methods used for interpolation processing of input video signals and input key signals.

For input video signals, you can select from the following four methods.



- Detect changes in the luminance and chrominance signals separately, and switch automatically between fields and frames. You can select the degree of change detection.
- Detect changes in the luminance signal separately, and switch automatically between fields and frames. You can select the degree of change detection.
- Do interpolation in field units.
- Do interpolation in frame units.

For input key signals, you can select from the following three methods.

- Detect changes in the luminance signal separately, and switch automatically between fields and frames. You can select the degree of change detection.
- Do interpolation in field units.
- Do interpolation in frame units.

You can also select the number of pixels used in interpolation processing, and select the method used to show the picture reduced or expanded.

Key Density Adjustment

You can adjust the key density for the key signal input to the DME.

Key Source Selection

You can select either the key signals received from the switcher or the key signals generated in the DME for application to the front and back of the image (*see page 111*).

Global Effects

Global effects are special effects created by combining the images of successive channels. The Global Effect menu is used to add these effects.

For details of this menu, see “Global Effect Operations” in Chapter 11 (Volume 2).

The following types of global effects are available.

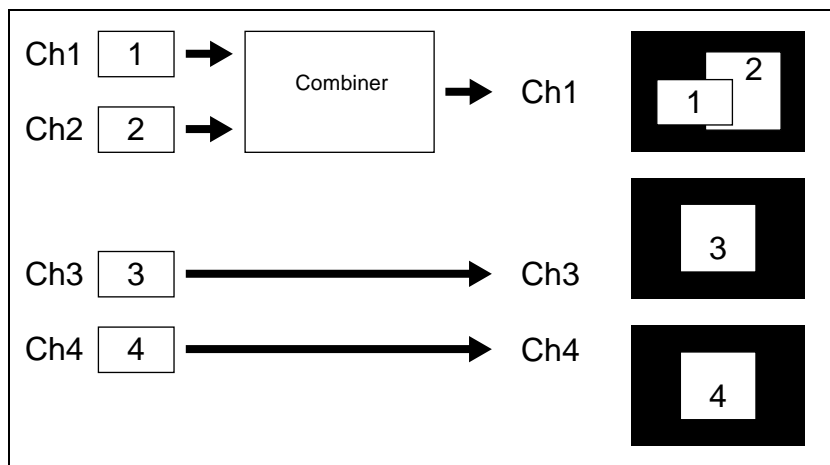
- Combiner
- Brick
- Shadow

Combiner

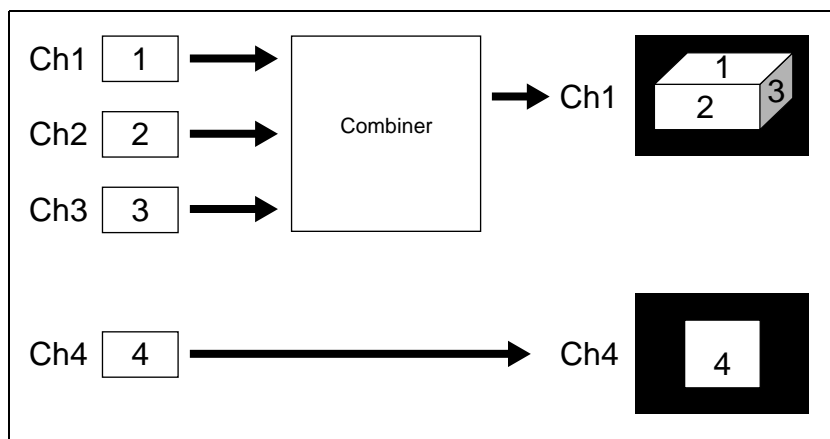
When multiple channels are selected on one key or for one transition, the Combiner automatically combines the selected images. Up to three channels can be combined.

You can also control the way in which the combination is carried out, as a mix or an overlap with priority set automatically. For a mix, you can control the relative amounts of each channel.

Combination of channel 1 (Ch1) and channel 2 (Ch2)

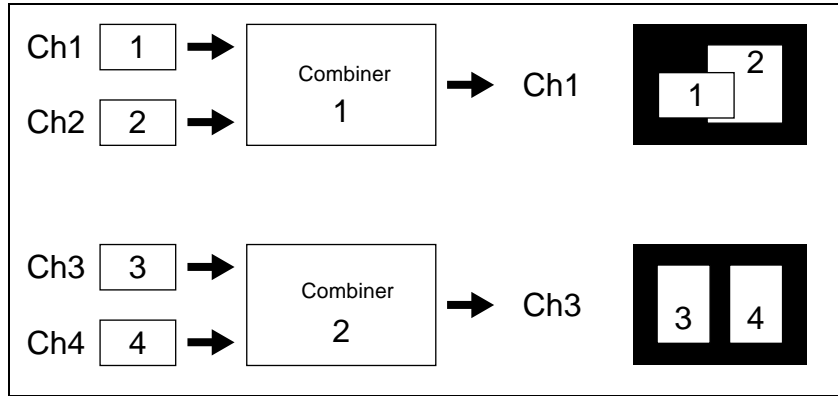


Combination of Ch1, Ch2, and Ch3

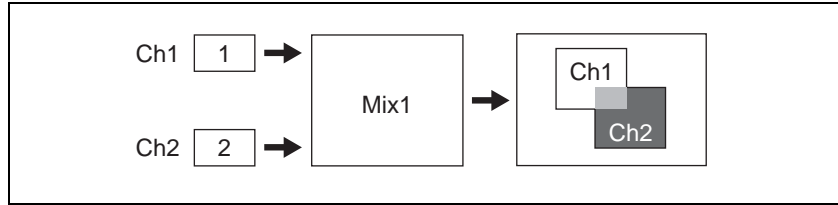




Combination of Ch1 and Ch2 / combination of Ch3 and Ch4



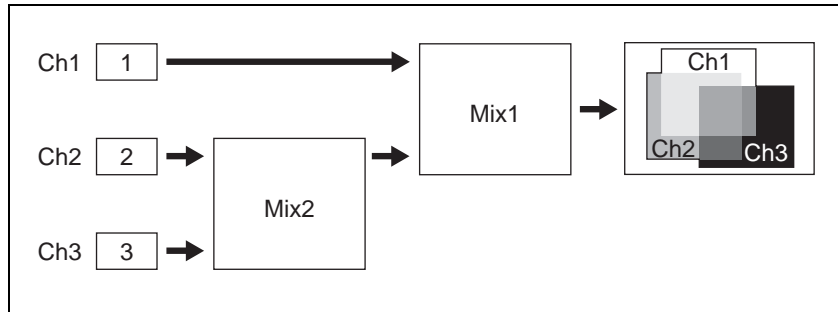
Mixing Ch1 and Ch2







If the Mix1 setting is 70, the proportion of the channels in the mixed portion in the illustration above is as shown in the following table.

Combination	Indication in figure	Ch1	Ch2
Ch1 and Ch2		30%	70%

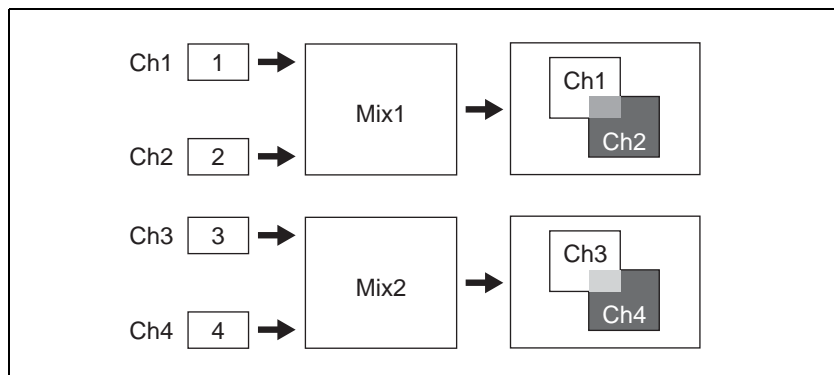
Mixing Ch1, Ch2, and Ch3





If the Mix1 setting is 70 and the Mix2 setting is 40, the proportions of the channels in the mixed portions in the illustration above are as shown in the following table.

Combination	Indication in figure	Ch1	Ch2	Ch3
Ch1 and Ch2		30%	70%	–
Ch2 and Ch3		–	60%	40%
Ch1 and Ch3		30%	–	70%
Ch1, Ch2, and Ch3		30%	42%	28%

Pairwise mixing of Ch1 and Ch2, and Ch3 and Ch4

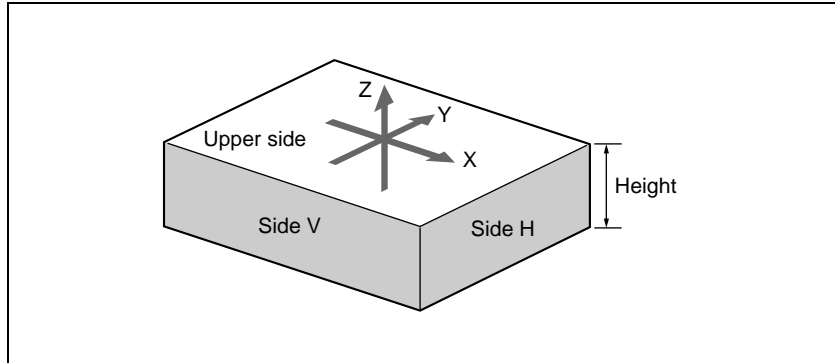


If the Mix1 setting is 70 and the Mix2 setting is 40, the proportions of the channels in the mixed portions in the illustration above are as shown in the following table.

Combination	Indication in figure	Ch1	Ch2	Ch3	Ch4
Ch1 and Ch2		30%	70%	–	–
Ch3 and Ch4		–	–	60%	40%

Brick

This effect creates a rectangular parallelepiped from 3 successive channels. The Brick effect can combine Ch1, Ch2, and Ch3, or combine Ch2, Ch3, and Ch4. The three images are displayed as shown below.



An example of the Brick effect

Combinations of Ch1, Ch2, and Ch3

Upper side: Ch1 image

Side V: Ch2 image

Side H: Ch3 image

Combinations of Ch2, Ch3, and Ch4

Upper side: Ch2 image

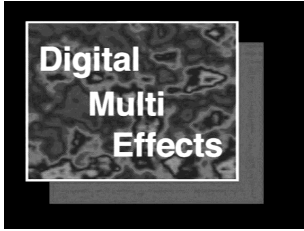
Side V: Ch3 image

Side H: Ch4 image

You can adjust the height of the brick, the overlap between the three images and the way to insert the side images.

Shadow

This effect gives the image a shadow. The effect uses two successive channels. You can adjust the position and density of the shadow with respect to the image, and the color of the shadow. The channel with the largest number (for example, Ch2 in the case of Ch1 and Ch2) becomes the shadow.



External Devices

In the DVS-9000 system, you can operate while controlling the following types of external device:

- Devices supporting P-BUS (Peripheral II protocol) (referred to as “P-BUS devices” in the manual)
- Devices supporting GPI
- VTRs
- Disk recorder (Sony disk 9-pin protocol)

The following is an outline of external device control.

For external device control operations, see Chapter 12 “External Devices” (Volume 2). For details on the devices that can be connected, consult your Sony representative.

Shared Functions for External Device Control

Keyframe functions

There are 99 registers, numbered 1 to 99, holding external device control data as keyframe data.

The following are the keyframe functions that can be used.

- RECALL (1-99), STORE (1-99), RECALL UNDO, STORE UNDO, empty register search, AUTO SAVE, RECALL MODE (RECALL, RECALL & REWIND)
- EDIT ENABLE, EDIT UNDO
- CONST DUR, EFF DUR, KF DUR, DELAY, PAUSE, INSERT BEFORE, INSERT AFTER, MODIFY, DELETE, COPY, PASTE BEFORE, PASTE AFTER, FROM TO, ALL
- PREV KF, NEXT KF, GOTO TC, GOTO KF, RUN, REWIND, FF, STOP NEXT KF, NORMAL, JOG, KF FADER

Note

Actions set in a keyframe are executed only when the keyframe effect is executed in the normal direction. Take care when executing simultaneously with a switcher or DME keyframe effect, since the actions are not executed in the reverse direction.

The following keyframe functions cannot be used.

- KF LOOP, EFFECT LOOP, REVERSE, NORMAL/REVERSE
- PATH

Saving to registers

Set the data for controlling external devices in the Device menu. You can save the set data in keyframe, snapshot, or shotbox registers. You can recall the register in which the data is saved, and carry out operations on it with the keyframe control block.

For details, see Chapter 12 “External Devices” (Volume 2).

Register manipulation functions

You can carry out the following operations on the registers in which the data for controlling external devices is saved.

- Copy
- Move
- Swap
- Merge (this cannot be carried out for registers holding VTR or disk recorder control data.)
- Lock
- Name

File related functions

As effect data, you can save and recall, using the File menu.

Control of P-BUS Devices

You can control P-BUS devices from the DVS-9000 system through the 9-pin serial port of a DCU.

P-BUS device control modes

There are two modes of P-BUS device control, as follows.

P-BUS trigger mode: Operating a previously specified button outputs the command for an action assigned to that button.

P-BUS timeline mode: Carrying out a keyframe effect under the control of the center control panel controls external devices.

In the setup, select which of P-BUS trigger mode and P-BUS timeline mode to use.

P-BUS trigger mode actions

The actions that can be used in P-BUS trigger mode are as follows.

- Store
- Recall
- Trigger

For details of the buttons assigned to each action, see Chapter 12, “External Devices” (Volume 2).

P-BUS timeline

At a keyframe point on the P-BUS timeline, you can set an action (setting what action command is output to which device). At any single keyframe point you can set actions for a maximum of 24 devices.

P-BUS timeline mode actions

The actions that can be used in P-BUS timeline mode are as follows.

- Store
- Recall
- Trigger

For the action setting (or P-BUS timeline editing), use the Device menu.

You can save the data set in the Device menu in keyframe effect registers.

Recalling the register starts execution of the keyframe effect, and when this reaches the keyframe point at which actions are set, action commands are output to external devices through the 9-pin serial port assigned to P-BUS.

For details, see Chapter 12 “External Devices” (Volume 2).

Control of GPI Devices

You can control GPI devices from the control panel of an DVS-9000 system, or through the GPI output port of a DCU.

GPI timeline

For a keyframe effect controlled from the center control panel, the GPI timeline allows you to set an action (setting a trigger output from a particular GPI output port) at a keyframe point on the GPI timeline. At any keyframe point, you can make a maximum of eight GPI output port settings.

GPI timeline actions

The actions that can be used on the GPI timeline are as follows.

- Control panel GPI output port
- DCU GPI output port

For the GPI output settings (keyframe editing), use the Device menu.

The data set in the Device menu are saved in a keyframe effect register. When you recall this register and start execution of the keyframe effect, and advance the effect to the keyframe point for which the GPI output is set, a trigger pulse is output to the external device from the specified GPI output port.



VTR/Disk Recorder Control

You can carry out the following manual operations and timeline settings for up to 12 VTRs or disk recorders connected to a DCU.

- Controlling manually from the device control block (MKS-8031).
- Saving a start point, stop point, start delay time and variable speed in a data register, then recalling the register to control automatically from the keyframe control block.
- In the Device menu, you can check the following VTR and disk recorder information:
 - Device name
 - Register number
 - VTR status
 - Current time
 - Start point
 - Stop point
 - Variable speed
 - Start delay time

Manual operation

In the device control block, you can carry out the following operations manually.

- **VTR or disk recorder selection**
- **Tape transport and disk drive control:** You can use the following tape transport control buttons: REW, PLAY, FF, CUE UP, VAR PLAY, SHTL, JOG, STANDBY OFF, STOP, and ALL STOP. (*For details of the operation of the buttons, see “Device Control Block (Trackball)” (page 183) and “Device Control Block (Joystick)” (page 187).*)
Depending on the settings made in the Setup menu, the CUE UP, PLAY and STOP operations can be carried out from the transition control block (standard type). (*For details of the operation of the buttons, see “Transition Control Block (Standard Type)” (page 173), “Device Control Block (Trackball)” (page 183) and “Device Control Block (Joystick)” (page 187).*)
- **Setting a start point:** For each selected VTR you can set the start point timecode value as keyframe data.
- **Setting a stop point:** For each selected VTR you can set the stop point timecode value as keyframe data.
- **Setting a start delay time:** For each selected VTR you can set the start delay time as keyframe data.



Cueup & Play

By saving the start point timecode, stop point timecode, and start delay time for a VTR or disk recorder in an effect register, and recalling this register, you can operate the following buttons in the keyframe control block to automatically control the VTR or disk recorder.

[REWIND] button: Cue up to the start point timecode

[RUN] button: Play

With this function you can also stop the VTR or disk recorder used for playback at the stop point timecode recalled from the same register.

VTR/disk recorder timeline

For a keyframe effect controlled from the center control panel, the VTR/disk recorder timeline allows you to set a VTR or disk recorder action at a keyframe point on the timeline.

VTR/disk recorder timeline actions

The actions that can be used on the VTR/disk recorder timeline are as follows.

- Start
- Stop
- Cue up
- Variable speed

Note

For a disk recorder, the maximum number of files for a single register is 8.

For the action settings (VTR or disk recorder timeline editing), use the Device menu.

The data set in the Device menu are saved in a keyframe effect register. When you recall this register and start execution of the keyframe effect, and advance the effect to the keyframe point for which the action is set, an action command is output to the external device through the 9-pin serial port assigned to the VTR or disk recorder.

Recalling disk recorder files

Material held on a disk recorder is managed in units of files. You can recall a file to play it back.

Accessing the file list

Before playback and suchlike operations on a disk recorder, it is first necessary to display a list of the disk recorder files on the DCU. The file list includes the following information.

- File name
- Date of last update

- Duration of recorded material
- To recall the file list, use the Device menu.

Recalling a file

In the recalled list of files, select the file you want to play back, and open the file.

File list sharing

You can connect multiple DCU serial ports to a single disk recorder. You can share the recalled list of files between serial ports connected to the same disk recorder.

For settings relating to file list sharing, see “Serial Port Settings (Serial Port Assign Menu)” in Chapter 16 (Volume 2).

Regions and Registers

Regions

The term “region” refers to some sort of functional block of the system. When saving or recalling snapshot registers and effect registers, or creating or editing effects, you first select the region to which the operation applies. You can also select multiple regions simultaneously.

Classification of the regions

The regions are classified as follows.

- MASTER region
- The following 31 regions
 - Switcher: M/E1 to M/E3, PGM/PST, USER1 to USER8
 - DME: DME1 to DME4 (inclusive of Global)
 - External devices: P-BUS, Router, Device 1 to Device 12, GPI

Only the regions assigned to the region selection buttons of the numeric keypad control block can be used simultaneously.

For details of the region assignment to the region selection buttons, see “Overall Control Panel Settings (Config Menu)” in Chapter 16 (Volume 2).

Regions applicable to keyframe operations

Thirty regions, that is, the above regions less the Router region.

Regions applicable to snapshot operations

Sixteen regions, that is, the above regions less the four types of external devices.

“USER” regions

You can optionally assign the following regions to the regions USER1 to USER8.

- Color backgrounds 1 and 2
- AUX1 to AUX48
- Monitor 1 to 8
- Frame Memory 1 to 8

For details of the USER1 to USER8 region assignment, see “Overall Control Panel Settings (Config Menu)” in Chapter 16 (Volume 2).

Reference region

When multiple regions are selected, only one region appears in the displays for menu and numeric keypad operations. This is called the “reference region.”

The reference region is determined according to the following precedence.

M/E1 >M/E2 >M/E3 >P/P >USER1 > USER2 > USER3 > USER4
>USER5 > USER6 > USER7 > USER8 > DME1> DME2 > DME3
> DME4 > P-BUS

Master region

The regions saved in a master snapshot register or master timeline register and the register numbers saved in such regions can be recalled at a time as the master region.

The master region can be saved or recalled using the numeric keypad control block.

Registers

A register is an area of memory in a device which holds a snapshot, keyframe, and so on.

Keyframe effect registers

Dedicated effect registers

There are 99 dedicated registers for keyframe effects in each region, numbered 1 to 99.

Shared user-programmable DME registers

In addition to the 99 DME registers for each region (i.e. each channel), there are also shared registers for each processor as shown in the following table.

These are used for user-programmable DME.

Register number	Register allocation
101 to 199	Shared register for one-channel effects
201 to 299	Shared register for two-channel effects

Note

When operating with these shared registers, be sure to select the appropriate regions depending on the number of channels. When recalling registers in the 200 range, select two consecutive channels for the regions, as for example [DME1] and [DME2].

Work register

This is a temporary register used when editing keyframes.

When you recall an effect, it is read from the effect register into the work register, and when you save, the contents of the work register are written to the effect register.

Master timeline registers

There are 99 master timeline registers, numbered 1 to 99, for each control panel. They store keyframe effect regions and the register numbers saved in the regions.

Snapshot registers

These are registers for snapshots, and there are 99, numbered 1 to 99 for each region.

Master snapshot registers

There are 99 master snapshot registers, numbered 1 to 99, for each control panel. They store snapshot regions and the register numbers saved in the regions.

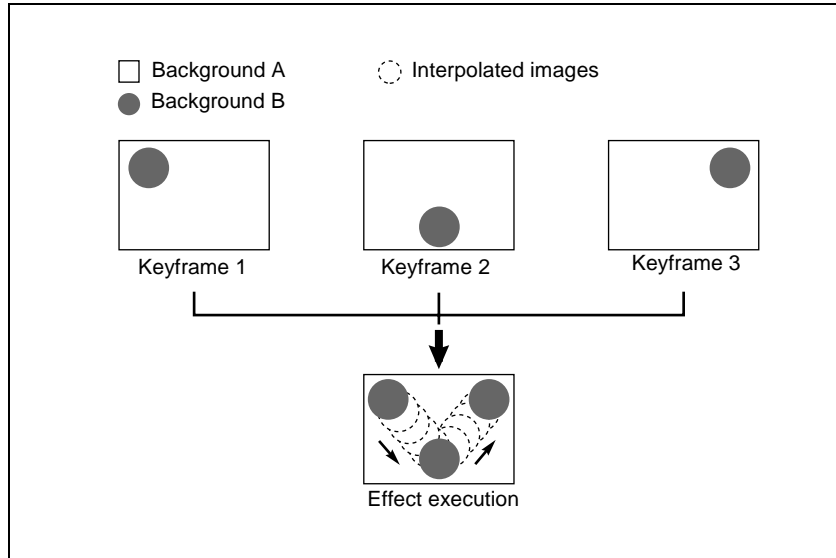
Keyframes

A keyframe represents an instantaneous state of an image; it can be saved and recalled for reuse.

Effects

By arranging a number of keyframes on the time axis, and interpolating between successive keyframes, you can create an effect in which there is a continuous change from each keyframe to the next.

The figure below shows three keyframes created with a wipe pattern (the circle) in different positions. This is interpolated to create the effect shown.



Example of keyframes and effect execution

You can save the sequence of keyframes representing a single effect in a register. Then by recalling this register, you can replay the same effect.

For details of keyframe effect registers, see “Regions and Registers” (page 124).

Saving and Recalling Effects

To create a new effect, first recall an empty register, then create the keyframes one at a time in this register. To run an effect, it is also necessary to set the time and the path.

To edit an existing effect, recall the register holding the effect, then make the changes.

When you have finished creating or editing the effect, save it in the recalled register or another specified register.

Auto save function

When you recall an effect, the currently recalled effect is automatically saved in a register. This is called the auto save function. You can disable this function in a Setup menu.

Effect Attributes

An individual effect may also have attached special conditions relating to switcher or DME operation when the effect is recalled.

These conditions are called “attributes” of the effect, and can be added when the keyframe effect is saved or recalled.

Type of attribute

The attribute that can be attached to an effect is as follows.

Effect dissolve: The transition from the state before the effect recall to the state at the effect start point is carried out smoothly, by a dissolve. The dissolve duration can be set in the Effect menu.

Temporary attributes

When a keyframe is recalled, independently of the attributes held in the register, you can also enable or disable temporary attributes. These temporary attributes are set when the keyframe effect is recalled.

Effect Editing

For editing operations such as to insert, delete, or modify a keyframe, it is necessary to stop the effect at the corresponding point on the time axis. This is termed an “edit point.”



You can edit either on a keyframe within the effect, or at any point between keyframes.

Insert: Insert the current image as a keyframe. Inserting a keyframe in an existing effect may change the duration of the effect (*see page 131*).

Modify: Modify a keyframe. You can modify a single keyframe or a range of keyframes in the effect together.

Delete: Delete a keyframe. You can delete a single keyframe or a range of keyframes in the effect together. Deleting keyframes from an effect reduces the duration of the effect (*see page 131*).

After deleting a keyframe, you can reinsert the keyframe with a paste operation.

Copy: Copy a keyframe. You can copy a single keyframe or a range of keyframes in the effect together.

Paste: Paste the keyframe last copied or deleted anywhere within the effect.

Pause: You can set a pause on a particular keyframe, so that when the effect is run it pauses on this keyframe. You can make this setting on any number of keyframes. To restart the paused effect, repeat the operation to run the effect.

KF Loop: Execute the effect the specified number of times through the keyframes in the specified range.

Undo an edit operation: Undo the effect of the last operation to insert, modify, delete, or paste a keyframe.

Duration modes

In keyframe editing, there are two duration modes; switch between them in the keyframe operation section. (*See “Time Settings” in Chapter 13 (Volume 2).*)

Variable duration mode: In this mode, inserting or deleting a keyframe increases or reduces the duration.

Constant duration mode: In this mode, inserting or deleting a keyframe does not change the duration. This is useful for keyframe editing of an effect with a fixed duration.

In the variable and constant duration modes, the keyframes to which a modify operation applies, and the effect of a paste operation are different.

Difference in keyframes to which a modify operation applies

Effect position	Variable duration mode	Constant duration mode
On a keyframe	Applies to currently selected keyframe	Applies to currently selected keyframe
Between two keyframes	Applies to previous keyframe	Modify operation not possible ^{a)}

a) A new keyframe is inserted at the effect position.

Difference in the effect of a paste operation

Variable duration mode: The copied keyframe is inserted at the specified position.

Constant duration mode: The copied keyframe is written over the specified position.

Transition mode

You can use an effect created with keyframes as a DME wipe pattern on the switcher. In this case, it is necessary to set the transition mode (the way in which the effect behaves).

For details of the setting, see “User Programmable DME Transition Mode” (page 342).

Time Settings

Keyframe duration and effect duration

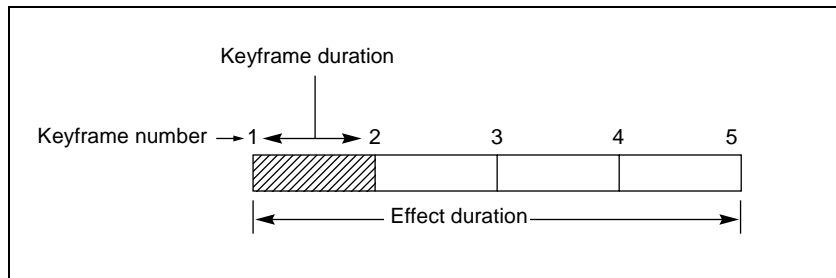
You can determine the execution time of an effect by setting either the keyframe durations or the effect duration.

Keyframe duration: This is the time from the keyframe to the next keyframe. You can set this time in the keyframe control block. (See “Time Settings” in Chapter 13 (Volume 2).)

In constant duration mode (see page 129), it is not possible to change the keyframe duration setting.

Effect duration: This is the total execution time of the effect, from the first keyframe to the last. You can set this time in the keyframe control block. (See “Time Settings” in Chapter 13 (Volume 2).)

When you change the effect duration, the keyframe duration for each keyframe in the effect is automatically recalculated proportionally.



Schematic view of keyframe duration and effect duration

The effect duration may also be changed by inserting or deleting keyframes.

Changes in the effect duration caused by inserting a keyframe

- When the effect is stopped on a keyframe, inserting a keyframe increases the effect duration by the duration of the inserted keyframe.
- When the effect is stopped between two keyframes, inserting a keyframe does not change the effect duration.

Note

In constant duration mode (*see page 129*), the duration of the current keyframe is reduced to zero, and the new keyframe is inserted with the previous duration of the current keyframe. Thus the effect duration does not change.

Insertion position	Change in effect duration
Insertion before the first keyframe	
Insertion between two keyframes	
Insertion at an existing keyframe	
Insertion at the last keyframe	

Keyframe insertion position and the change in effect duration

Changes in the effect duration caused by deleting a keyframe

- When the effect is stopped on a keyframe, a delete operation deletes the keyframe, and reduces the effect duration by the duration of the deleted keyframe.



- When the effect is stopped between two keyframes, a delete operation deletes the preceding keyframe, and reduces the effect duration by the duration of the deleted keyframe.

Note

In constant duration mode (*see page 129*), the duration of the keyframe before the deleted keyframe is increased by the duration of the deleted keyframe. Thus the effect duration does not change.

Deletion position	Change in effect duration
Deletion of the first keyframe	
Deletion of an intermediate keyframe	
Deletion between two keyframes	
Deletion of the last keyframe	

Keyframe deletion position and the change in effect duration

Delay setting

You can set the delay from the time of executing an operation to run the effect, and the effect actually starting (that is, the delay until the first keyframe). You can make this setting in the keyframe control block. (*See “Time Settings” in Chapter 13 (Volume 2).*)

Note that changing the delay does not alter the duration of the effect.

Paths

The term “path” refers to the specification of how interpolation is carried out from one keyframe to the next.

For details of the path setting procedure, see “Path Settings” in Chapter 13 (Volume 2).

Switcher path settings

Carry out path settings in the Key Frame menu.
For each menu, the following settings are available.

M/E-1 to M/E-3, and P/P menus

Item	Paths that can be set	
M/E1 to M/E3, P/P All	For each M/E and PGM/PST, path settings for the following items are made simultaneously.	
Key1 to Key4	Overall path settings for items relating to keys 1 to 4 are made simultaneously.	
Key 1 All to Key 4 All		
Source		Key source path for keys 1 to 4
Fill		Key fill path for keys 1 to 4
Proc		Proc path for keys 1 to 4
Trans	Transition path for keys 1 to 4	
Bkgd/Util	Overall path settings for items relating to backgrounds and utility buses are made simultaneously.	
Bkgd/Util All		
Bkgd A		Path for background A
Bkgd B		Path for background B
Util 1		Path for utility 1
Util 2	Path for utility 2	
Wipe/DME Wipe	Overall path settings for items relating to wipes and DME wipes are made simultaneously.	
Wipe		Wipe/DME Wipe All
Wipe		Path for wipes
DME Wipe	Path for DME wipes	
Trans	–	Transition path for each M/E and P/P bank

User1 to User8 menus

The items that can be adjusted depend on the settings in the Setup menu.

For details, see “Overall Control Panel Settings (Config Menu)” in Chapter 16 (Volume 2).

Item		Paths that can be set
User1 All to User8 All		Overall path settings for the following items for each "User" are made simultaneously.
FM All		Overall path settings for frame memory items are made simultaneously.
FM Src		Overall path settings for frame memory source items are made simultaneously.
	FM Src All	
	FM Src1	Path for frame memory source 1 and video process
	FM Src2	Path for frame memory source 2 and video process
FM Proc		Overall path settings relating to the signal processing other than frame memory source and frame memory freeze outputs are made simultaneously.
	FM Proc All	
	FM Proc1	Path for frame memory signal processing 1
	FM Proc2	Path for frame memory signal processing 2
FM Still Store		Overall path settings for frame memory freeze image output are made simultaneously.
	FM Still Store All	
	FM Still Store 1 to 8	Paths for frame memory freeze image outputs 1 to 8
Aux		Overall path settings for Aux buses are made simultaneously.
	Aux All	
	Aux 1 to 48	Paths for Aux 1 to 48
Mon		Overall path settings for monitor buses are made simultaneously.
	Mon All	
	Mon 1 to 8	Paths for monitor buses 1 to 8
Color Bkgd		Overall path settings for color backgrounds are made simultaneously.
	Color Bkgd All	
	Color Bkgd 1/2	Paths for color backgrounds 1 and 2

Paths relating to DME

Note

To carry out path operations relating to DME requires the BKDS-9470 DME Board Set.

DME 3D Trans Local menu

Item	Paths that can be set
3D Trans Local All	Overall path settings for local channel three-dimensional transform items are made simultaneously.
Loc Size	Overall path settings for items relating to image size changes and movement are made simultaneously.
Loc Size All	
Size	Path for image size
Post Loc X, Post Loc Y	Paths for movement in the x- and y-axes
Post Size	Path for size
Loc XYZ	Overall path settings for items relating to image movement are made simultaneously.
Loc XYZ All	
Loc X, Loc Y, Loc Z	Paths for the x-, y- and z-axes
Rot	Overall path settings for items relating to image rotation are made simultaneously.
Rot All	
Rot X, Rot Y, Rot Z	Paths for the x-, y- and z-axes
Spin	Overall path settings for items relating to spin are made simultaneously.
Spin All	
Spin Src X, Spin Src Y, Spin Src Z	Paths for the x-, y- and z-axes
Spin X, Spin Y, Spin Z	Paths for the x-, y- and z-axes
Asp	Overall path settings for items relating to aspect ratio are made simultaneously.
Asp All	
Rate X, Rate Y	Paths for the x- and y-axes
Skew	Overall path settings for items relating to skew are made simultaneously.
Skew All	
Skew X, Skew Y	Paths for the x- and y-axes
Aspect	Path for aspect ratio
Pers	Overall path settings for items relating to perspective are made simultaneously.
Pers All	
Pers X, Pers Y, Pers Z	Paths for the x-, y- and z-axes
Axis Loc	Overall path settings for items relating to image rotation axis are made simultaneously.
Axis All	
Axis X, Axis Y, Axis Z	Paths for the x-, y- and z-axes

DME 3D Trans Global menu

Item	Paths that can be set
3D Trans Global All	Overall path settings for three-dimensional transform items in the global channel are made simultaneously.
Loc Size	Overall path settings for items relating to image size changes and movement are made simultaneously.
Loc Size All	
Size	Path for image size
Post Loc X, Post Loc Y	Paths for movement in the x- and y-axes
Post Size	Path for size
Loc XYZ	Overall path settings for items relating to image movement are made simultaneously.
Loc XYZ All	
Loc X, Loc Y, Loc Z	Paths for the x-, y- and z-axes
Rot	Overall path settings for items relating to image rotation are made simultaneously.
Rot All	
Rot X, Rot Y, Rot Z	Paths for the x-, y- and z-axes
Spin	Overall path settings for items relating to spin are made simultaneously.
Spin All	
Spin Src X, Spin Src Y, Spin Src Z	Paths for the x-, y- and z-axes
Spin X, Spin Y, Spin Z	Paths for the x-, y- and z-axes
Pers	Overall path settings for items relating to perspective are made simultaneously.
Pers All	
Pers X, Pers Y, Pers Z	Paths for the x-, y- and z-axes
Axis Loc	Overall path settings for items relating to image rotation axis are made simultaneously.
Axis All	
Axis X, Axis Y, Axis Z	Paths for the x-, y- and z-axes

DME Effect menu

Item	Paths that can be set
Effect All	Overall path settings for DME effect items are made simultaneously.
Edge	Overall path settings for edge items are made simultaneously.
Edge All	
Border	Path for border
Crop/Edge Soft	Path for crop/edge softness

Item	Paths that can be set
Video Modify	Overall path settings for video modify items are made simultaneously.
Video Modify All	
Defocus/Blur	Path for defocus/blur
Multi Move	Path for "multi-move"
Color Modify	Path for color modify
Mosaic	Path for mosaic
Freeze	Path relating to freeze
Non-Linear	Path relating to nonlinear effects
Light	Path relating to lighting
Trail	Path relating to trails
In/Out	Overall path settings for items relating to input/output are made simultaneously.
In/Out All	
Bkgd	Path for background
Video/Key	Path for video/key

DME Global Effect menu

Item	Paths that can be set
Global Effect All	Overall path settings for DME global effect items are made simultaneously.
Combine	Path relating to combiner
Shadow	Path relating to shadow
Brick	Path relating to brick

Types of path

Path types for Curve

There are five types, as follows.



OFF: Executing the effect causes no change.



Step: There is no interpolation between keyframes, so that the effect parameters are updated each time a keyframe is passed.



Linear: Linear interpolation between keyframes, resulting in constant speed movement.



S-Curve: The rate of change accelerates and decelerates before and after a keyframe, so that the rate of change is maximum midway between two keyframes.



Spline: The effect follows a smooth curved path from each keyframe to the next.

Path types for Hue

There are four types, as follows.



CW: The hue changes in a clockwise direction as seen on a Vectorscope.



CCW: The hue changes in a counterclockwise direction as seen on a Vectorscope.



Short: The hue changes in whichever of the clockwise and counterclockwise directions is shorter.



Long: The hue changes in whichever of the clockwise and counterclockwise directions is longer.

Path types for Xpt

There are two types, as follows.



Xpt Hold off: When replaying a keyframe, change the inputs to the settings saved in memory.



Xpt Hold on: When replaying a keyframe, do not change the inputs.

Effect Execution

By pressing the [RUN] button in the keyframe control block, you can replay the effect as a continuous sequence of images. This is referred to as effect execution.

It is also possible to execute effects from the device control block (*see page 183*).

Range of execution

Each time the [RUN] button is pressed, the range of execution of the effect is from timecode 01:00:00:00 or the current time (the position at which the current effect is stopped) to the end point of the effect. However, if there is a pause set on a keyframe, the execution range is up to that point. Pressing the [RUN] button again resumes the effect, which then runs to the next pause point or the end of the effect.

Run mode setting

You can select from the following run modes for when the effect is executed.

DIRECTION: Specify the effect execution direction.

STOP NEXT KF: Run the effect, and stop at the next keyframe.

EFFECT LOOP: Repeat the effect in an endless loop.

Make these settings in the keyframe control block. (*See “Run Mode Setting” in Chapter 13 (Volume 2).*)

Master Timelines

You can save the regions selected for a keyframe effect and the register numbers saved in the regions in a master timeline register so that operation can be applied to two or more regions at a time.

Master timeline registers can be saved or recalled from the numeric keypad control block or using a menu operation. (See “*Creating and Saving a Master Timeline*” in *Chapter 13 (Volume 2)*.)



Snapshots

The term “snapshot” refers to a function whereby the various settings required to apply a particular effect to an image are saved in memory as a set of data, for recall as required, to recover the original state.

You can carry out snapshot operations using the numeric keypad control block, the Flexi Pad control block in each of the M/E-1 to M/E-3 and PGM/PST banks, and the Snapshot menu.

For details of snapshot operations, see Chapter 14 “Snapshots” (Volume 2).

Snapshot Types

Snapshots are divided as follows.

Snapshots applying to a particular region (functional block of the switcher or DME)

The term “snapshot” alone usually refers to this type of snapshot.

Master snapshot: This applies to the selected regions and the register numbers saved in the regions. A master snapshot can be saved and recalled using the numeric keypad control block.

Snapshots applying only to particular functions

This type of snapshot includes the following.

Key snapshot: This includes the key on/off state and all key settings other than key priority for each keyer. (*See “Key Snapshots” (page 54).*)

Wipe snapshot: This includes the wipe settings of each of the M/E-1 to M/E-3 and PGM/PST banks. (*See “Wipe Snapshots” (page 67).*)

DME wipe snapshot: This includes the DME wipe settings of each of the M/E-1 to M/E-3 and PGM/PST banks.

Note

To carry out DME wipe snapshots requires the BKDS-9470 DME Board Set.

The rest of this section describes the snapshots that apply to a particular region or regions.



Snapshot Attributes

An individual snapshot may also have attached special conditions relating to switcher or DME operation when the snapshot is recalled. These conditions are called “attributes” of the snapshot, and can be added when the snapshot is saved or recalled.

Types of attribute

There are five snapshot attributes, as follows.

Cross-point hold: When the snapshot is recalled, the cross-point button selection remains unchanged. This can be set independently for each bus.

Key disable: When the snapshot is recalled, the key settings remain unchanged. This can be set independently for each keyer.

Effect dissolve: The transition from the state before the snapshot recall to the snapshot settings is carried out smoothly, by a dissolve. The dissolve duration can be set in the Snapshot menu.

Auto transition: An auto transition starts the instant the snapshot is recalled. The auto transition setting is valid only for M/E-1, M/E-2, M/E-3, and PGM/PST.

Note

If both effect dissolve and auto transition are selected as attributes, the auto transition takes precedence.

GPI output: A GPI output is sent to the allocated GPI port the instant the snapshot is recalled.

The trigger type depends on the switcher GPI output settings made in the Setup menu.

For details, see “Interfacing With External Devices (Device Interface Menu)” under “Setup Relating to Switcher Processor” in Chapter 16 (Volume 2).

Table of available attributes

The attributes that can be used depend on the region, as follows.

Yes: Can be used No: Cannot be used

Attribute	Region		
	M/E-1, M/E-2, M/E-3, and PGM/PST	USER 1 to USER 8	DME 1 to DME 8
Cross-point hold	Yes	Yes	Yes
Key disable ^{a)}	Yes	No	No

Attribute	Region		
	M/E-1, M/E-2, M/E-3, and PGM/PST	USER 1 to USER 8	DME 1 to DME 8
Effect dissolve	Yes	Yes	Yes
Auto transition	Yes	No	No
GPI outputs ^{b)}	Yes	Yes	No

a) Applicable only as temporary attributes, but not applicable by a menu operation.

b) Applicable only by a menu operation.

Attribute display

You can view the attributes of a snapshot in the Snapshot menu.

For more details, see “Snapshot Operations in the Menus” in Chapter 14 (Volume 2).

Temporary attributes

When recalling a snapshot, you can temporarily apply attributes distinct from the attributes set for each register. These are called “temporary attributes.”

You can set temporary attributes when recalling a snapshot.

For details of snapshot operations, see Chapter 14 “Snapshots” (Volume 2).

Bus override

If you recall a snapshot while holding down an A or B bus button, the selection of the signal on the A or B bus does not change when the snapshot is recalled. This function is called “bus override.”

This function is effective when cross-point hold is off, and you want to temporarily maintain the cross-point setting. When cross-point hold is on, the above operation is not necessary.

Utility

The utility function refers to a function whereby you can assign an arbitrary action or a shortcut for frequently used menu to a particular button, then instantly recall the action or menu by pressing the button.

The functions you can assign include menu shortcuts, enabling/disabling functions (recalling utility commands), and recalling (shotbox registers). Carry out the button assignment in the Setup menu.

For details of the operation, see “Setting Button Assignments (Prefs/Utility Menu)” in Chapter 16 (Volume 2).

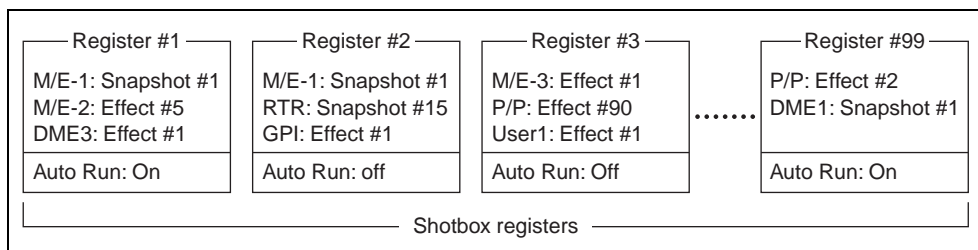
You can carry out the utility function in the utility/shotbox control block (*see page 199*) or using the user preference buttons in the menu control block (*see page 197*).



Shotbox

The term “shotbox” refers to a function whereby for each specified region any snapshot or keyframe effect can be recalled simultaneously.

The simultaneous recall setting data such as region names, snapshot numbers and keyframe effect numbers are stored in “registers.” There are 99 registers for each control panel.



The figure above shows schematically the settings in the 99 shotbox registers. Each register may contain any combination of the regions to which the register applies, with the snapshots or effects to be recalled.

The Auto Run function is an attribute which can be set for each register. When this is set to On, an effect recalled by a shotbox operation is automatically run.

- When register 1 is executed, this recalls M/E-1 snapshot 1, M/E-2 effect 5, and DME3 effect 1. For register 1, auto run is on, and therefore the M/E-2 and DME3 effects are run as soon as they have been recalled.
- When register 3 is executed, M/E-3 effect 1, P/P effect 90, and User1 effect 1 are recalled. For register 3, auto run is off, and therefore to run the recalled effects, press the [RUN] button in the keyframe control block.

Shotbox settings and execution

Carry out shotbox register settings from the Shotbox menu or using the numeric keypad control block.

You can carry out shotbox execution using the numeric keypad control block, the Flexi Pad control block, or the utility/shotbox control block.

For details of operation, see Chapter 15 “Shotbox” (Volume 2).

Setup

Overview of Setup

Various settings are required, in order to operate the switcher, control panel, DME, external devices, and so on, connected together in a single system. This is referred to as “setup,” and you can carry out the setup operations from the Engineering Setup menu.

For details of the operations, see Chapter 16 “Engineering Setup” (Volume 2).

The settings in the Engineering Setup menu are grouped under the following headings.

- **System setup (System):** Settings relating to the whole system (*see the following section “System Setup.”*)
- **Panel setup (Panel):** Settings particular to the control panel (*see page 149*)
- **Switcher setup (Switcher):** Settings particular to the switcher processor (*see page 151*)
- **DME setup (DME):** Settings particular to the DME processor (*see page 154*)
- **DCU setup (DCU):** DCU input and output settings (*see page 155*)
- **Router/tally setup (Router/Tally):** Router interface and tally settings (*see page 155*)

System Setup

The system setup settings apply to the whole system. Here the “whole system” refers to all devices connected on the Control LAN.

The DCU is connected through the control panel, but is also included in the “whole system.”

You can make the following settings.

Network configuration (Network Config)

This provides automatic configuration of all devices connected to the Data LAN (excluding the DCU), and displays a list of them.

System configuration (System Config)

Specify the overall system operation mode and the hierarchical relationship of the devices.



Operation mode setting

- **Single Proc mode:** The control panel controls a single switcher.
- **Dual Simul mode:** The control panel controls two switchers simultaneously.

Device hierarchical relationship setting

- **Panel Assign:** Specify the switcher controlled by a control panel.
- **Switcher Assign:** Specify the DME connected to a switcher.

Signal format settings (Format)

Make the following settings.

Signal format

Specify the signal format to be handled by the devices.
The combinations of signal formats that can be selected are as follows.

System	Field frequency	Effective number of scan lines
SD system	59.94	480i
	50	576i

Screen aspect ratio

Switch the screen aspect ratio to 4:3 or 16:9.

Selecting the start up state (Start Up)

Set the initial state of the devices when the system is powered on.
For each device, you can select Resume mode or Custom mode.

Resume mode

This resumes the setting state at the previous power-off operation. This setting is only available for the switcher processor and panel.

Custom mode

This uses the settings saved in non-volatile memory or ROM within the device. In this mode, there are Setup and Initial Status settings which can be set separately.

- **Setup mode:** Select the setup state to be used after powering on from the following.
 - User:** Start up using the user data previously saved with [Setup Define].
 - Factory:** Start up with the factory default settings.
- **Initial status mode:** Select the state of each device after powering on (excluding the settings to which “setup” applies).
 - User:** Start up using the user data previously saved with [Initial Status Define]. For the control panel, this applies to the key bus delegation buttons only.
 - Factory:** Start up with the factory default settings.

For details of saving and recalling setup data, see “Saving and Recalling Setup Data” (page 148).

System reset and memory initialization (Initialize)

- **Reset:** Reset to state after powering on.
- **All Clear:** Clear the memory, and carry out initialization. The Network Config, System Config, Format, and Start Up setup values are set by reference to data stored in non-volatile memory, and the system automatically starts up. It is not necessary to reset the Date/Time settings.

For more details, see “Saving and Recalling Setup Data” (page 148).

Installation (Install)

This installs the software and firmware in all devices (including the DCU) connected to the Data LAN.

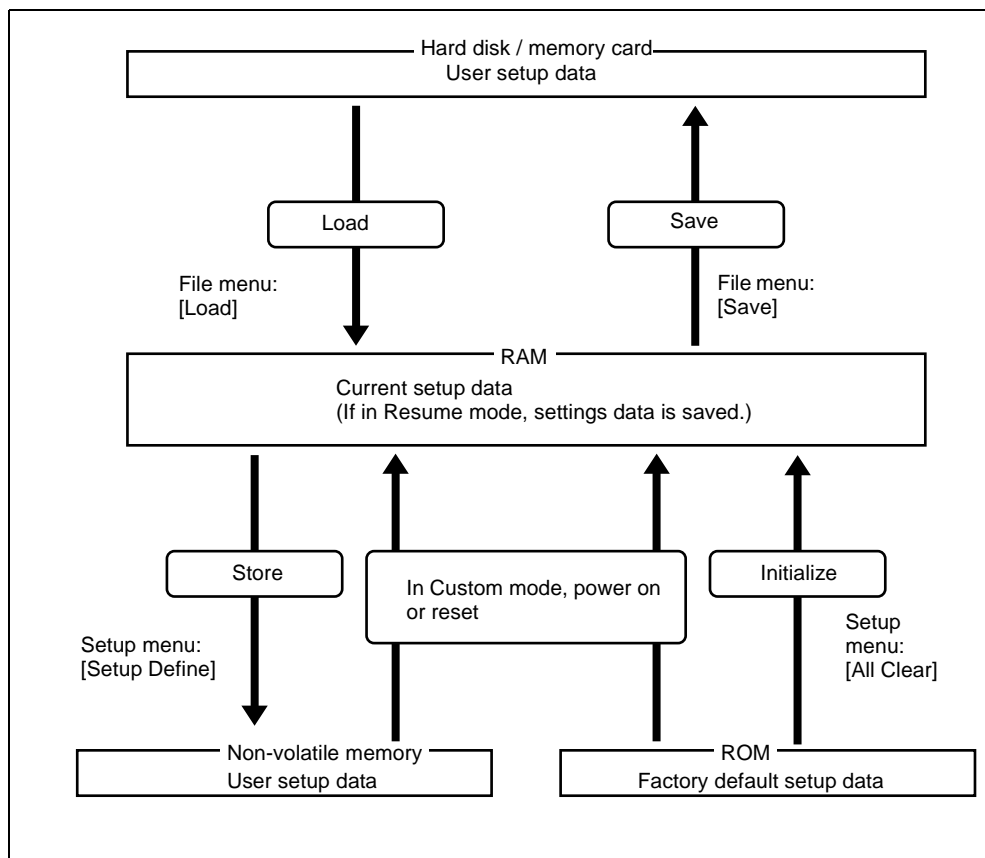
Standard Install mode: Installs the standard configuration. There are also the following functions.

Detail Information: Gives details of the software and firmware installed in each device.

Device management (Maintenance)

- Date and time setting
- Formatting a memory card
- Primary settings for USB external storage device
- Reloading a USB driver

Saving and Recalling Setup Data



Concept of saving and recalling setup data

Updating the switcher or control panel setup data saves the updated setup data in RAM in each device.

- In Resume mode (*see page 146*), even if devices are reset or powered off, the data is preserved in RAM, and recalled when the power is turned back on.

Note

The Resume mode cannot be used for DMEs and DCUs.

- In Custom mode (*see page 146*), the user-defined settings (user setup data) saved in non-volatile memory or factory default setup data held in ROM in each device is recalled when a reset is made or the power is turned back on. (*See "Selecting the start up state (Start Up)" (page 146).*)

Note that the setup data in RAM can also be saved to the control panel hard disk or memory card.

Panel Setup

In panel setup, you carry out settings particular to the control panel. You can make the following settings.

For details of the operations, see “Setup Relating to Operations From the Control Panel” in Chapter 16 (Volume 2).

Panel settings (Config)

- **M/E Assign:** Set the logical configuration of the M/E and P/P banks.
- **M/E Operation:** For each of the M/E and P/P banks, make operations possible, not possible, or disabled (Enable/Disable/Inhibit).
- **DSK Fader Assign:** Carry out fader function assignment and key delegation for the key delegation buttons, in each of the maximum of four downstream key control blocks.
- **External Bus Link:** Make link settings relating internal switcher buses to routing switcher destinations.
- **Key Trans Link:** Select whether or not to link transitions between keyers, and if so which keyer to link to. You can set the links between keyers for each M/E bank separately.
- **Reference Module:** When a trackball module and a joystick module are both connected as device control blocks, select which is used as the reference.
- **10 Key Region Assign:** Assign any regions to the region selection buttons in the numeric keypad control block.
- **Program Button:** Make settings for using the buttons in a standard type transition control block for controlling a VTR.

Cross-point button settings (Xpt Assign)

- **Multi Xpt Assign:** For each operating bank or bus, assign a main table and “sub” tables 1 to 4.
- **Xpt Assign:** Carry out main table settings.
 - Assign video/key sources for button numbers 1 to 128.
 - Set source names of up to 16 characters.
 - Set the LCD color for source name display.
 - For each cross-point table, specify whether the rightmost cross-point button in each row is used as a shift button, and the operation mode when it is used as a shift button.
- **Sub Table Assign:** For sub tables 1 to 4, set rearrangements of the button layout set in the main table. Also set the shift button mode.

- **Shift Mode:** For the [SHIFT] button in the cross-point control block, select the mode in which this is a shift button dedicated to the source display section, or the mode in which it is a shift button for all buses.
- **Name Export:** This function sends the source name and destination name to the S-BUS.

AUX bus settings (Aux Assign)

- **Aux Assign:** Assign the AUX delegation buttons in the auxiliary bus control block to any bus.
- **Shift Mode:** Specify whether the rightmost button of the AUX delegation buttons is used as a shift button, and when it is used as a shift button, the operation mode.

Button assignment settings (Prefs/Utility)

Assign the [PREFS 1] to [PREFS 8] buttons in the menu control block, and the utility/shotbox control block buttons.

- **User Preference:** Make the settings for the user preference buttons in the menu control block. This assigns recalling frequently used menus (menu shortcuts), enabling/disabling functions (recalling utility commands) and recalling shotbox registers.
- **Utility Module Assign:** Make the utility/shotbox control block settings. This assigns recalling frequently used menus (menu shortcuts), enabling/disabling functions (recalling utility commands) and recalling shotbox registers.

External device connections (Device Interface)

- **GPI Input:** Set the GPI input ports and trigger type, and make the action settings.
- **GPI Output:** Set the GPI output ports and trigger type, and make the action settings.
- **P-BUS Control:** Set the control mode for P-BUS devices.
- **DCU Serial Port Assign:** Assign the devices (DDR/VTR) connected to a DCU and accessible from the control panel to the DEV1 to DEV12 buttons of the control panel. For a DDR, you can also make settings relating to sharing of file lists.

Operation settings (Operation)

- **Button Tally:** Set whether or not the system tally generation results are reflected in the panel tally.
- **Trans Rate Display:** Select whether the transition rate display mode is in frames or timecode units.
- **Effect:** For keyframe effects, you can make the following settings. (*See Chapter 13 “Keyframe Effects” (Volume 2).*)

- Recall mode
- Automatically turning off the [EDIT ENBL] button when an effect is recalled
- Automatic insertion of a first keyframe when an empty register is recalled
- Effect Auto Save
- Default KF Duration
- Setting whether or not to replay the first keyframe after rewinding a GPI/P-BUS/DDR/VTR effect
- **Source/Dest Name:** For the Source/Dest (source/destination) names used by the system, select one of the following:
 - Source name set by cross-point assignment or fixed bus name
 - Description name set on routing switcher
 - “Type + No.” name set on routing switcher
- **Name Display:** Specify the number of characters for display of the names selected in Source/Dest Name above, as two characters, four characters, or Auto.
- **Flexi Pad:** Carry out Flexi Pad settings. Specify the delegation selection coupling, and display mode for the LCD buttons.
- **Custom Button:** Set the following button operation modes.
 - [ALL] button for next transition selection
 - [AUTO TRANS], [TAKE] or [FTB] button during auto transition execution
 - [RUN] button during keyframe execution
 - [UTIL] button
 - [TRANS PVW] button
 - [XPT HOLD] button in key rows
- **Sensitivity:** Adjust trackball, joystick and double-click sensitivity.
- **Main Split Fader:** When the split fader is active, specify whether the fader to control other than mix is the left side or the right side.

Screen saver, brightness adjustments, and alarm (Maintenance)

- **Screen Saver:** Make the menu screen saver settings.
- **LCD Brightness:** Adjust the LCD brightness.
- **LED Brightness:** Adjust the LED brightness.
- **Switch Brightness:** Adjust the switch brightness.
- **Touch Beep:** Select whether or not to sound a beep when a menu operation is carried out.
- **Touch Panel Calibration:** Calibrate the touch panel.

Switcher Setup

In switcher setup, make settings particular to the switcher processor.

You can make the following settings.

Settings relating to overall switcher configuration (Config)

- **System Phase:** Adjust the switcher internal reference phase.
- **Switch Timing:** Specify the timing of video switching.
- **M/E Config:** Set the program configuration for the M/E and P/P outputs.
 - **Standard mode:** Fix the maximum of four outputs (Out1 to 4) and program output configuration as follows.
 - Out1: Program output
 - Out2: Preview output
 - Out3: Clean output
 - Out4: Key preview output
 - Program output: Clean output + key 1 + key 2 + key 3 + key 4
 - **Multi-program mode:** Increase the number of M/E or P/P programs, and assign any of the following to the maximum of six outputs (Out1 to 6).
 - Program outputs 1 to 4, preview output, key preview outputs 1 and 2, clean output.
 - Further, you can select the program background from Clean or Utility2, and change the combination of signals from which it is configured.
 - Again, you can set the key preview configuration to video mode or key mode. In key mode, select whether to link operation to the on/off state of the key, or have it always on.
 - **DSK mode:** Treat P/P as four DSKs, with no background transitions. Of backgrounds 1 to 4, set one to configure the program output. The signals which can be selected as the background are limited to Out1 to 6 from M/E-1 to M/E-3.
- **K-PVW Config:** Set the key preview configuration to either video mode or key mode. In key mode, select whether to link the key state to the on/off operation, or have it always on.
- **User 1 to 8 Config:** Assign the User regions, being color backgrounds 1 and 2, AUX1 to 48, monitor 1 to 8, and frame memory 1 to 8, to any of USER1 to USER8.
- **Logical M/E Assign:** Make settings for handling PGM/PST hardware logically as an M/E.

Input signal settings (Input)

- **Input Phase Adjust:** Carry out phase adjustment for each primary input.
- **Through Mode:** Set through mode for the input side. This applies only to the primary inputs, and can be set independently for each primary input.
- **Video Process:** Switch video processing on or off for each input signal, and adjust the brightness, hue and so forth.
- **Matte Illeg. Color Limit:** Switch the illegal limiter on or off for the signal generated by the switcher internal matte generator.



Output signal settings (Output)

- **Output Assign:** Assign the signals output from the Output1 to 48 ports.
- **Video Clip:** Adjust the clip levels (White Clip, Dark Clip, and Chroma Clip) for the output signals from each of the Output1 to 48 ports.
- **V Blank:** Adjust the vertical blanking width for the output signals from each of the Output1 to 48 ports. The setting is the number of scan lines from the reference blanking position of field 1 for the particular format which should be masked.
- **Through Mode:** Enable or disable through mode. Through mode can be enabled for AUX1 to 48 outputs, M/E and PGM/PST program outputs, and clean output.
- **Safe Title:** Enable or disable safe title, and carry out settings for box 1 and 2 and cross.
- **Ref. Output Phase:** Set the reference output mode and phase adjustment.

Settings relating to video switching (Transition)

- **Transition Preview:** Specify the operation mode for transition preview for each of the M/E and P/P banks.
- **Key Transition:** Specify the operation mode for independent key transitions.
- **Bus Toggle:** Switch the bus toggle for each of the M/E and P/P banks on or off.
- **Split Fader:** When the bus toggle is off, the split fader settings are enabled. For each of the M/E and P/P banks, select enable or disable.
- **Fade To Black:** Enable or disable fade-to-black for each final program output.
- **Preset Color Mix:** Set the stroke mode for a preset color mix, the key status for a transition including a key, and the mode in which the transition type after a transition ends returns to the previous setting.
- **Transition Curve:** Set the relationship when carrying out a transition, between the fader lever position and the advancement state of the transition.

Key, wipe and frame memory settings (Key/Wipe/FM)

- **Key Memory:** Set the key memory operation mode for each of the M/E and P/P banks.
- **Video Proc Memory:** Enable or disable video process memory.
- **Show Key:** Enable or disable show key for edit preview, M/E and P/P Pvw/K-Pvw.
- **DSK Auto Drop:** Specify a DSK to be turned off automatically when a cross-point button on the P/P program bus is pressed.
- **Mask/Border Process:** Set the processing order of masks and borders for each M/E and P/P bank.
- **Key Priority:** Set the key priority operation mode for each of the M/E and P/P banks. In DSK mode, the key priority is fixed.



- **Xpt Hold mode:** Set the operation mode for the cross-point hold button provided on the key bus for each of the M/E and P/P banks.
- **Pattern Limit Transition:** Set the operation mode when the pattern limit is released for each of the M/E and P/P banks.
- **Wipe Edge Default:** Adjust the wipe edge softness for each of the M/E and P/P banks.
- **FM Auto Store:** Switch on or off the function to automatically attach a name and save in frame memory.

Link settings (Link)

- **Internal Bus Link:** Make a setting of the bus link function that links together two buses internal to the switcher.
- **GPI Link:** Make settings for linking any cross-point buttons or [CUT] and [AUTO TRANS] buttons in the cross-point control block and GPI output ports.

External device connections (Device Interface)

- **Remote Assign:** Set the use of the four 9-pin ports.
- **GPI Input:** Set the GPI input ports and trigger polarities, and make the action settings.
- **GPI Output:** Set the GPI output ports and trigger polarities, and make the action settings.
- **Aux Control:** Set whether operations on the Aux buses from the four 9-pin ports are inhibited.

DME Setup

In DME setup, carry out settings particular to the DME processor.
You can make the following settings.

Input signal settings (Input)

- **Initial Crop:** Make the initial crop setting.
- **Matte Illeg. Color Limit:** Switch the illegal limiter for the signal generated by the DME internal matte generator on or off.

Interface with external devices (Device Interface)

- **Editor Protocol:** Set the protocol to be used on the Editor port.
- **Editor Port Setting:** Make settings relating to the control of the four editor ports installed in the DME.
- **GPI Input:** Set the GPI input ports and trigger polarities, and make the action settings.

- **GPI Output:** Set the GPI output ports and trigger polarities, and make the action settings.

Setup Relating to DCU Input/Output

In DCU setup, carry out settings particular to the DCU.

You can make the following settings.

- **Input Config:** Assign GPI inputs to Parallel input ports.
- **GPI Input Assign:** Make GPI input settings.
- **Output Config:** Assign GPI outputs to parallel output ports inserted in an option slot.
- **GPI Output Assign:** Make GPI output settings.
- **Serial Port Assign:** Set the protocol to match the devices connected to a 9-pin serial port. You can also select the control panel used to control each device.

Setup Relating to the Router Interface and Tally Interface

Carry out settings relating to the interface with the routing switcher, and settings relating to the tally interface.

You can make the following settings.

Router interface setup (Router)

These settings are common to the parallel tally and serial tally.

- **Matrix Size:** Assign the switcher matrix of each switcher processor to S-Bus space, and select the matrix size and positioning level, source address settings, and so on.
- **External Box:** To obtain the signal selection status of external devices with a parallel input, assign a matrix as an external selector in the S-Bus space. Make the matrix size, assignment level, source address, and other settings.

Tally interface setup (Tally)

Group tally settings (Group Tally)

- **Tally Group:** Select the group tally (Gp1 to 4 or Gp5 to 8) which can be used.
- **S-Bus Tally Enable:** Specify S-Bus tally enabled or disabled.

Wiring information input (Wiring)

Input the information which specifies the physical wiring between switcher and routing switcher or between two routing switchers.

These settings are common to the parallel tally and serial tally.

Tally enable settings (Tally Enable)

Specify the destination to be the reference for tally generation, and make various settings.

These settings are common to the parallel tally and serial tally.

- **Tally Type:** Specify the tally type. The tally types which can be specified are as follows:

When Group Tally is Gp1 to 4: R1, R2, R3, R4, G1, G2, G3, G4

When Group Tally is Gp5 to 8: R5, R6, R7, R8, G5, G6, G7, G8

- **Destination:** Specify the address and level.
- **Tally Enable:** Specify the timing at which a tally is enabled.

Enable: Always enabled.

Disable: Always disabled.

Tally Input No.: Follow the tally input status.

Copy (Tally Copy)

Copy the tally information pertaining to a particular source to a different source.

These settings are common to the parallel tally and serial tally.

Parallel port settings (Parallel Tally)

Make the parallel port settings for output of tally information pertaining to sources and destinations.

For each of the tally output terminal numbers, specify the tally type, and source address or destination level and address.

Serial tally settings (Serial Tally)

Make the serial tally settings, including tally type and source address for each serial tally port.

Simple Connection to MKS-8080/8082 AUX Bus Remote Panel

To connect the MKS-8080/8082 AUX Bus Remote Panel to a CCP-8000 Center Control Panel using an S-BUS data link requires a BKPF-R70A Routing Switcher Controller Board or similar primary station and various settings for connection.

However, using a simple connection, the need for an S-BUS data link primary station is avoided, and direct connection to the MKS-8080/8082 is possible.

A simple connection is possible if the following conditions are met:

- There are no devices other than the CCP-8000 and MKS-8080/8082 connected on the S-BUS data link.
- There are no more than 16 MKS-8080/8082 units connected on the S-BUS data link.

For details of the connection procedure, see “Procedure for Simple Connection” in Chapter 16 (Volume 2).



Files

You can save register data, including setup information and snapshot information, as a file on a hard disk or memory card, and recall it as required. You can operate on individual files or registers, or together in a batch. Regarding frame memory, it is possible to capture image data stored in an external device into frame memory. You can also convert the format of image data in frame memory into a different format and save it in an external device.

Files that can be manipulated

The following files can be saved and recalled.

- Operation mode setup data for system as a whole and individual devices
- Device status data for system startup
- Key memory setting data
- Video process memory setting data
- Keyframe effect setting data
- Snapshot setting data
- Wipe snapshot setting data
- DME wipe snapshot setting data
- Key snapshot setting data
- Shotbox setting data
- Macro setting data
- Macro attachment data
- Frame memory image data

File operations

You can carry out the following file operations.

When operating on individual files or registers

Save: Save the data in a register to the hard disk or memory card.

Load: Load a file from the hard disk or memory card.

Copy: Copy a file within a directory or from one directory to another. When a remote panel is used, this function applies to it, too.

Rename: Rename a file on the hard disk or memory card.

Delete: Delete a file from the hard disk or memory card.

When operating on files or registers in a batch

Only the above Save, Load and Delete operations are performable.



Importing or exporting files to or from frame memory

Import: Import a file in a different format from hard disk or memory card into frame memory after changing its format.

Export: Export a file in a register to hard disk or memory card after changing its format.

The supported file formats are TIF and BMP.



Macros

The term “macro” refers to the function whereby a sequence of signal selections and other operations on the control panel is saved as data in memory, so that it can be recalled as required to automatically execute the same sequence of operations.

For details of macro operations, see “Macros” in Chapter 18 (Volume 2).

Macro registers

The area of memory that holds a macro is termed a “macro register.” For each control panel there are 99 macro registers, numbered 1 to 99.

Events

The individual control panel operations constituting a macro are termed “events.” One macro can contain a maximum of 99 events.

The following table shows the operations for each control block of the control panel that can be saved as events in a macro.

Control block	Event
Auxiliary bus control block	Bus selection
Cross-point control block	Bus selection
Transition control block (standard type)	<ul style="list-style-type: none">• Auto transition and key insertion/deletion for the independent key transition execution section• Auto transition and cut for the transition execution section
Transition control block (simple type)	Auto transition for the transition execution section.
Transition control block (compact type)	<ul style="list-style-type: none">• Auto transition for the independent key transition execution section• Auto transition and cut for the transition execution section
Independent key transition control block (simple type)	<ul style="list-style-type: none">• Auto transition and cut for the independent key transition execution section• Auto transition for the transition execution section
Flexi Pad control block (standard type)	<ul style="list-style-type: none">• Effect recall• Snapshot recall
Flexi Pad control block (simple type)	Snapshot recall

Control block	Event
Numeric keypad control block	<ul style="list-style-type: none"> • Effect recall • Snapshot recall
Keyframe control block	Keyframe rewind and run
Device control block (trackball)	VTR start point setting
Device control block (joystick)	VTR start point setting
Downstream key control block	Auto transition and cut for the independent key transition execution section

Macro editing

You can create or edit a macro by recalling a macro register.

To create a new macro, recall an empty macro register, and create the desired sequence of events (by executing the sequence of operations on the control panel that you want to save as events in the macro).

To add an event to an existing macro, recall the register holding the macro, and create the event you want to add. For this, use the auto insert function (a function that automatically adds the events to the macro as you carry it out on the control panel).

Note

While editing a macro, it is not possible to execute another macro.

Macro execution and pause events

To execute a macro, recall the register in which the macro is held.

Simultaneous with the register recall, all events stored in the macro are played back (executed) in sequence without pause.

Pause event

To adjust the execution timing of a particular event (to delay the start of execution of the event by a particular time interval), you can store a special event which pauses macro execution. This event is called a “pause event.”

When you store a pause event, you can set the interval for which the macro is paused (the pause length) to any value in the range 1 to 999 frames.

Macro attachment

Macro attachment is a function whereby a macro register is assigned to a control panel button, linking the execution of the button function with a macro execution.

Select one of the following three linking modes to make the macro attachment. Carry out the linking mode selection in the PGM/PST bank or M/E bank cross-point control block.



Pre-macro: Mode in which the button function is executed after macro execution has completed

Post-macro: Mode in which the macro is executed after carrying out the button function

Macro only: Mode in which the button function is not executed, and the macro only is executed

You can assign any one of the 99 macro registers to a button.

For a button whose function is switched by delegation, you can make a separate macro attachment for each function.

For each control panel, you can make up to 1000 macro attachment settings.

Notes

- The buttons for which a macro attachment can be made are the background A and background B rows of buttons in the PGM/PST bank and the M/E banks only.
- After setting a macro attachment for a cross-point button, if in setup you change the function assigned to that button (*see “Cross-point button settings (Xpt Assign)” (page 149)*), the macro attachment may be canceled.

Enabling and disabling macro attachment

You can temporarily disable the macro attachment settings. When a macro attachment is disabled, pressing the button does not cause execution of the assigned macro.

You can enable and disable macro attachments for the PGM/PST bank and M/E banks individually.

Clearing the macro attachments

You can clear all of the macro attachments in a single operation.

Chapter 2 Menus and Control Panel

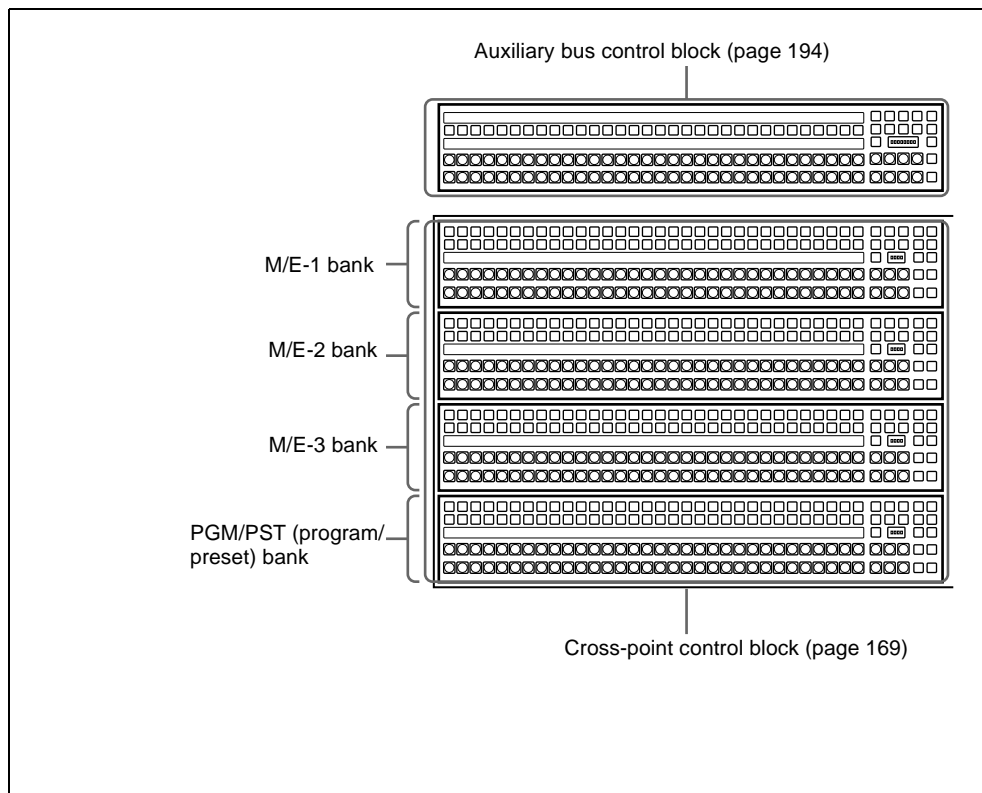
Names and Functions of Parts of the Control Panel	164
Control Panel: Example Configuration 1 (With Standard Transition Modules).....	164
Control Panel: Example Configuration 2 (With Simple Transition Modules)	166
Control Panel: Example Configuration 3 (With Compact Transition Modules)	168
Cross-Point Control Block.....	169
Transition Control Block (Standard Type).....	173
Flexi Pad Control Block (Standard Type)	177
Key Control Block.....	179
Device Control Block (Trackball)	183
Device Control Block (Joystick)	187
Keyframe Control Block	188
Numeric Keypad Control Block.....	191
Fade to Black Control Block	193
Auxiliary Bus Control Block.....	194
Menu Control Block	197
Memory Card/USB Adaptor Block.....	198
Utility/Shotbox Control Block.....	199
Transition Control Block and Flexi Pad Control Block (Simple Type) 200	
Independent Key Transition Control Block (Simple Type)	203
Downstream Key Control Block	205
Transition Control Block (Compact Type).....	207
Basic Menu Operations	210
Menu Organization	210
Accessing a Menu.....	215
Interpreting the Menu Screen	216
Menu Operations	217

Names and Functions of Parts of the Control Panel

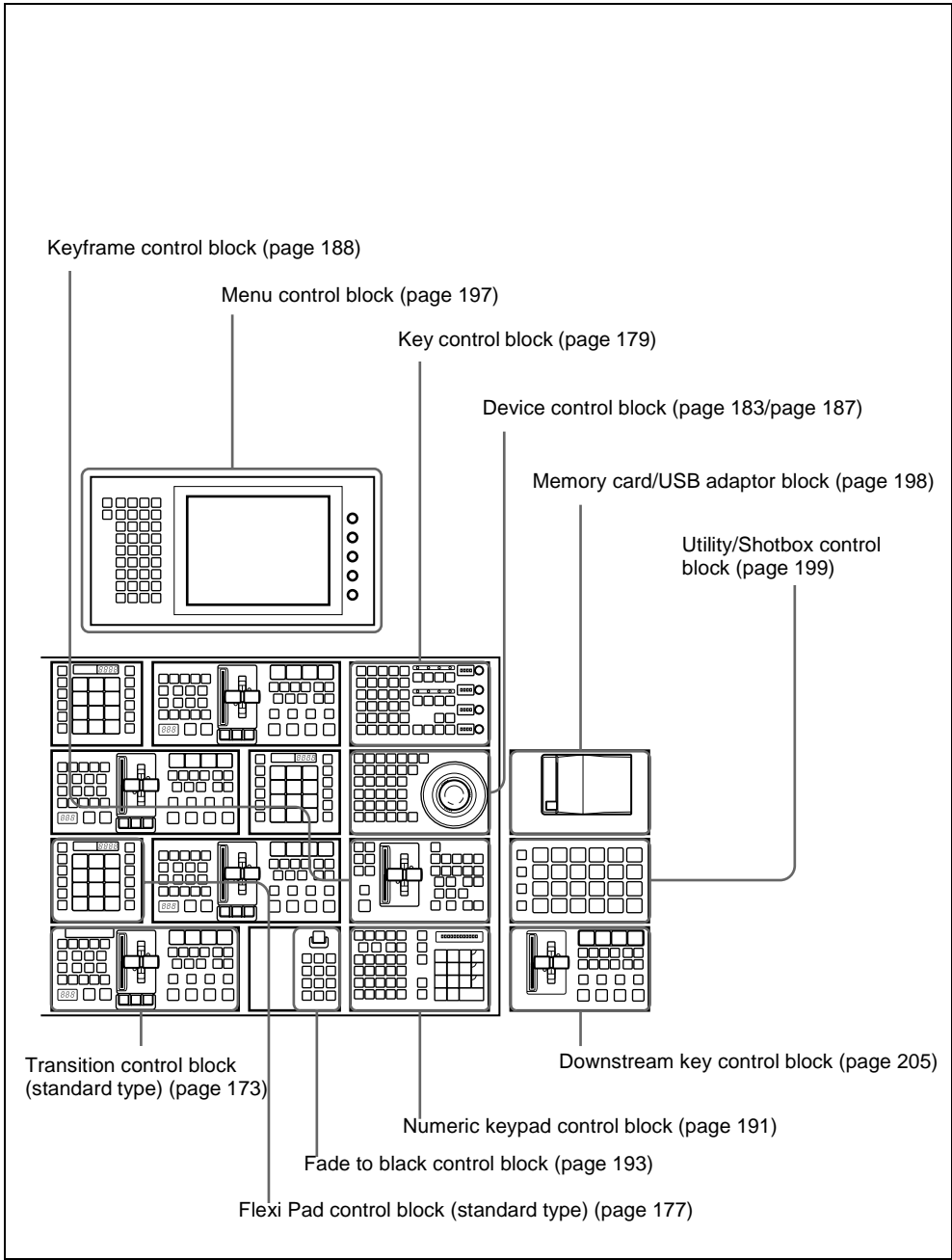
Control Panel: Example Configuration 1 (With Standard Transition Modules)

The DVS-9000 system control panel comprises a number of modules. The following illustration shows a typical 32-button, 4-M/E configuration, with

standard transition modules used in the transition control block.



Control panel configuration 1 (left side)
(with standard transition modules)

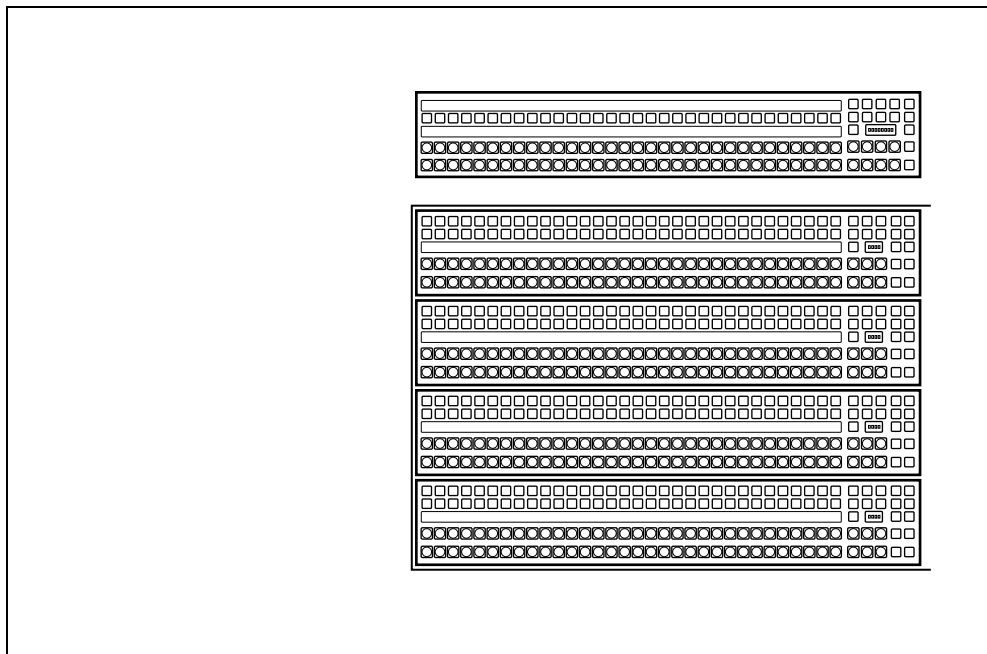


Control panel configuration 1 (right side)
(with standard transition modules)

Control Panel: Example Configuration 2 (With Simple Transition Modules)

The following illustration shows a typical configuration, with simple transition modules used in the transition control block.

Except for the simple modules, this is the same configuration as in example configuration 1.

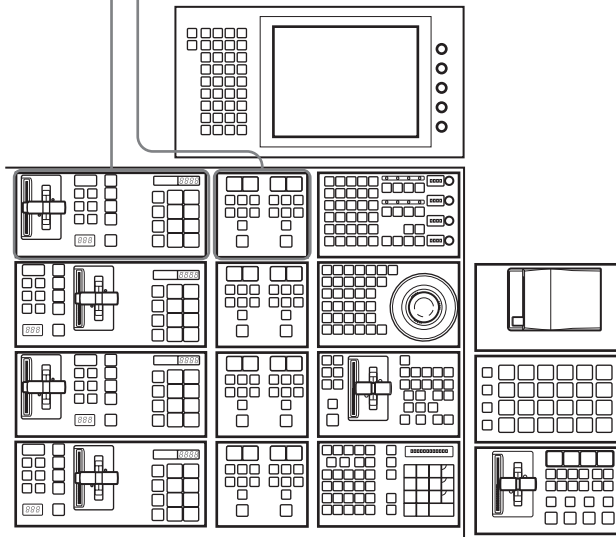


Control panel configuration 2 (left side)
(with simple transition modules)



Transition control block and Flexi Pad control block (simple type) (page 200)

Independent key transition control block (simple type) (page 203)

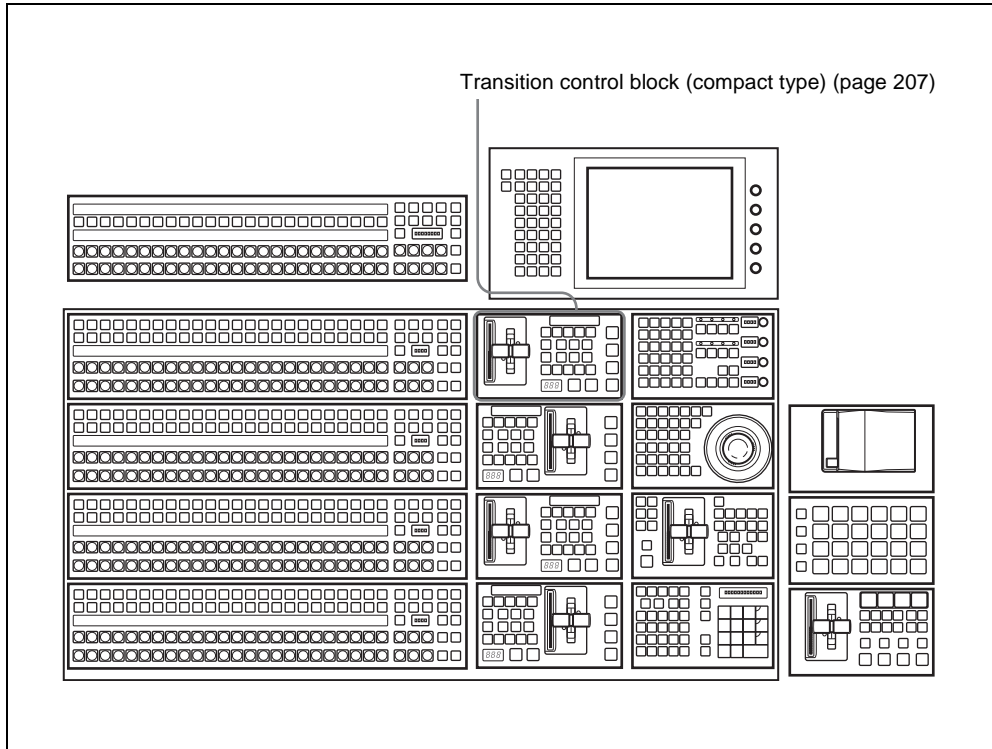


Control panel configuration 2 (right side)
(with simple transition modules)

Control Panel: Example Configuration 3 (With Compact Transition Modules)

The following illustration shows a typical configuration, with compact transition

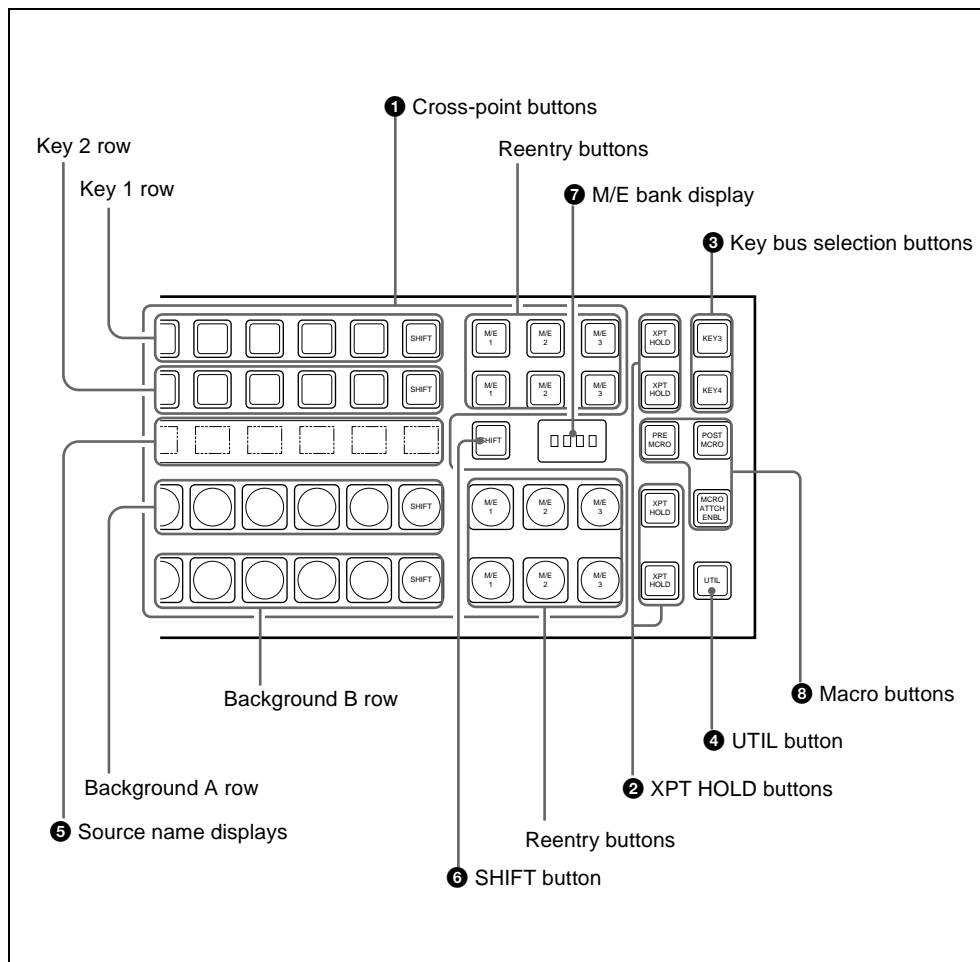
modules used in the transition control block.



Control panel configuration 3
(with compact transition modules)

Cross-Point Control Block

In the cross-point control block, you can select the signals to be used in this M/E bank or PGM/PST bank.



1 Cross-point buttons

These buttons select the signals used for video creation on this M/E bank or PGM/PST bank. Each row of buttons corresponds to one or more signal buses within the switcher.

Key 1 row: The buttons in this row select the key 1 or key 3 signals to be inserted into the video on this M/E bank or PGM/PST bank.

To select the key 1 fill signal, check that the right-hand [KEY3] button in the M/E bank (or the [DSK3] button in

the PGM/PST bank) is off, then press the button assigned to the desired signal. To select the key 3 fill signal, press the [KEY3] button, turning it on. While the [UTIL] button on the right hand side is held down, these buttons are assigned to the DME external video bus allowing you to select the signal on that bus.

Key 2 row: The buttons in this row select the key 2 or key 4 signals to be inserted into the video on this M/E bank or PGM/PST bank.

To select the key 2 fill signal, check that the right-hand [KEY4] button in the M/E bank (or the [DSK4] button in the PGM/PST bank) is off, then press the button assigned to the desired signal. To select the key 4 fill signal, press the [KEY4] button, turning it on. While the [UTIL] button on the right hand side is held down, these buttons are assigned to the DME utility 1 or 2 bus as follows.

- When the [KEY4] button is off, holding down the [UTIL] button assigns these buttons to the DME utility 1 bus.
- Holding down the [UTIL] button and pressing the [KEY4] button, turning it on, assigns these buttons to the DME utility 2 bus.

Background A row: Press the desired button to select the signal as the current background video on this M/E bank or PGM/PST bank.

While the [UTIL] button on the right hand side is held down in Hold mode, these buttons are assigned to the utility 1 bus, and can be used to select the signal on that bus.

Background B row: Press the desired button to select the signal as the background after the next transition on this M/E bank or PGM/PST bank.

While the [UTIL] button on the right

hand side is held down in Hold mode, these buttons are assigned to the utility 2 bus, and can be used to select the signal on that bus.

Reentry buttons: These allow you to select the video created on another bank as background A or B or one of the keys 1 to 4. For example, to use the video created on the M/E-1 bank as background B on the M/E-2 bank, press the reentry button [M/E 1] in the background B row of buttons on the M/E-2 bank.

Cross-point button numbers

This description applies to the example of a 32-button system.

From the left, the first 31 buttons are numbered 1, 2, ... 30, 31. When the 32nd button is set to be a [SHIFT] button, these buttons can also be switched to select signals numbered from 32 to 62. While the [SHIFT] button is held down, these switch to numbers 32 to 62, or alternatively, every time the button is pressed, switching is made between numbers 1 to 31 and 32 to 62. Similarly, the reentry buttons can be switched between two sets of numbers: 121 to 123, and 125 to 127.

Both the assignment of the 32nd button to a [SHIFT] button and the selection of the button operation mode can be done in a Setup menu.

Assigning signals to button

You can assign a signal to each button using the Setup menu.

This assignment is common to the cross-point buttons in the M/E-1, M/E-2, M/E-3, and PGM/PST banks, and the auxiliary bus control block. According to the settings made in the menu, the video and key signals are assigned to the cross-point buttons in pairs.

You can also make separate signal assignments for each operating control block.

Visual indications on cross-point buttons

The currently selected button in a row (i.e. the last button pressed) lights amber or red.

Amber (“low tally”): The signal selected on the bus does not form part of the program output from the switcher.

Red (“high tally”): The signal selected on the bus forms part of the program output from the switcher.

② XPT (cross-point) HOLD buttons

Turning one of these buttons on enables you to recall a keyframe or snapshot while keeping the current cross-point selection unchanged.

When the [XPT HOLD] button in the key 1 or key 2 row is on, then the operation is as follows, depending on the setting in the Setup menu.

When the panel setup is “Normal”: The operation is as follows, depending on the setting in switcher setup.

Key Disable: The snapshot or keyframe is recalled without changing the current key settings.

Xpt Hold: The snapshot or keyframe is recalled without changing the current cross-point selection.

When the panel setup is “Protect”: The cross-point settings cannot be changed by pressing panel buttons.

③ Key bus selection buttons

KEY3 button: Press this button, turning it on, to assign the key 1 cross-point buttons to the key 3 fill bus.

KEY4 button: Press this button, turning it on, to assign the key 2 cross-point buttons to the key 4 fill bus.

④ UTIL (utility) button

While this button is held down, the cross-point buttons are assigned to the following buses, respectively.

Background A row: utility 1 bus

Background B row: utility 2 bus

Key 1 row: DME external video bus

Key 2 row: DME utility 1 bus when the [KEY4] button is off, or DME utility 2 bus when the [KEY4] button is lit.

In a Setup menu, you can select either of the following two modes for these buttons.

- The button takes effect while being held down.
- Every time the button is pressed, it toggles between the on and off states for key 1 and key 2 rows. For background A and background B rows, utility buses remain disabled.

⑤ Source name displays

These show the names of the signals which can be selected on the cross-point buttons, in two or four characters, or in auto mode. While the [SHIFT] button on the right hand side or the [SHIFT] button assigned to the column of cross-point buttons is enabled, the source name of the signal assigned to the column of cross-point buttons in shift mode appears. You can select green, orange, or yellow for the background color of the source name display, for each source separately. You can set the source name display mode and background color in a Setup menu.

⑥ SHIFT button

When this button is enabled, either the source name displays show the shifted signal names, or the shifted signals for all buses in this M/E (P/P) bank are enabled. You can select either mode in a Setup menu.

Each press of the button toggles between the enabled and disabled states.

7 M/E bank display

This indicates the notional mix/effect bank name to which the particular M/E or PGM/PST bank is assigned, as a four-character identifier.

8 Macro buttons

PRE MCRO (pre macro) button: Use this button to set a macro attachment in pre macro mode. A macro attachment for macro only mode can also be set by using this button in combination with a macro only set button.

POST MCRO (post macro) button: Use this button to set a macro attachment in post macro mode. A macro attachment for macro only mode can also be set by using this button in combination with a macro only set button.

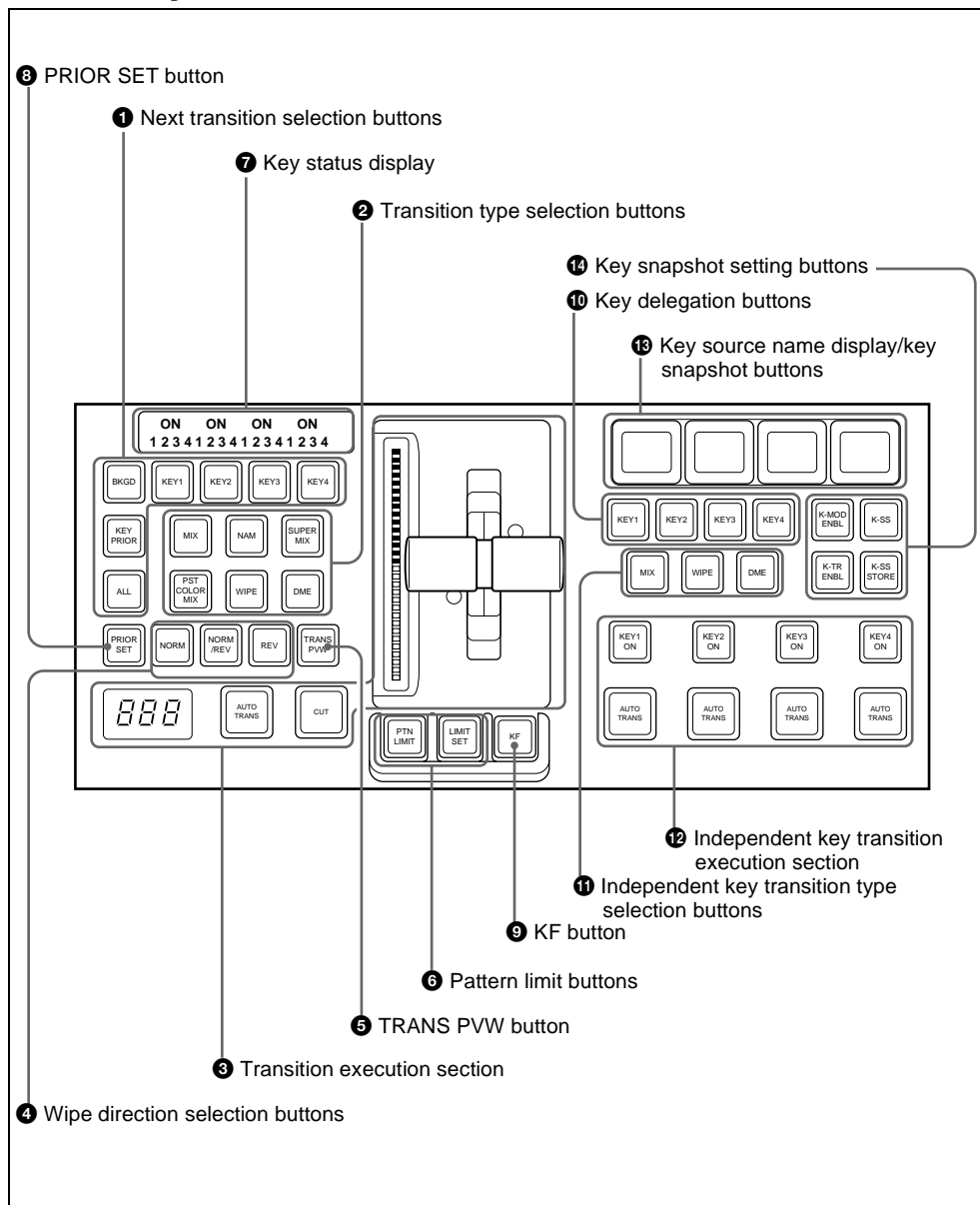
MCRO ATTCH ENBL (macro attachment enable) button: When this button is on, the macro attachments set for the buttons of the M/E bank are enabled and it is possible to execute macros using the buttons of the M/E bank.



Transition Control Block (Standard Type)

In the transition control block, you can modify the output of the M/E bank or PGM/PST bank, and perform transitions. Both

common transition and independent key transition operations are possible.





❶ Next transition selection buttons

Press these buttons, turning them on, to determine what the next transition will apply to.

BKGD: Next transition changes the background.

KEY1 to KEY4 (DSK1 to DSK4 in the PGM/PST bank): Press this button, turning it on, to make the next transition insert or remove the corresponding key (keys 1 to 4). If a key is currently inserted it will be removed, and vice versa.

In the PGM/PST bank, this inserts or removes downstream keys 1 to 4.

KEY PRIOR (priority): When this button is lit, the setting of the key priority after the next transition is enabled. The key priority after the next transition appears in the key status display.

ALL: Pressing this button turns on a preselected set of the [BKGD], [KEY1] to [KEY4], and [KEY PRIOR] buttons. Make this setting in a Setup menu.

❷ Transition type selection buttons

Press one of these buttons, turning it on, to determine the type of the next transition. When multi-program mode is selected in the Setup menu (see “Settings for Switcher Configuration (Config Menu)” in Chapter 16 (Volume 2)), two or more of the following buttons may light.

MIX: In a background transition, the new video fades in as the current video fades out. During the transition, the overall signal level is maintained at 100%.

In a key transition, the key fades in (for insertion) or out (for removal).

NAM (non-additive mix): The current and new video signals are compared, and the signal with the higher luminance level is given priority in the output. The current video is maintained at 100% output for the first half of the

transition as the new video increases progressively to 100%, then the current video is progressively reduced from 100% to zero in the second half while the new video is maintained at 100%.

SUPER MIX: The current video is maintained at 100% output for the first half of the transition as the new video is mixed while increasing progressively to 100%. The current video is then progressively reduced from 100% to zero in the second half while the new video is maintained at 100%.

PST (preset) COLOR MIX: In the first transition, the current video is replaced by the color matte in a mix (dissolve), then in the second transition the color matte is replaced by the new video also in a mix (dissolve).

WIPE: The current video is replaced by the new video, using the wipe pattern selected in the Wipe menu.

DME: A wipe type of transition is carried out, using the DME effect selected in the DME Wipe menu.

❸ Transition execution section

Transition indicator: This comprises 30 LEDs, which show the progress of the transition.

Fader lever: Move this to carry out a manual transition.

Transition rate display: This shows the “transition rate” (the time from the beginning of a transition to its completion) set for an auto transition, in frames.

You can set the transition rate using the numeric keypad control block, Flexi Pad control block, or menu.

AUTO TRANS (transition) button:

Pressing this button carries out an auto transition of the set transition rate (duration). The transition starts immediately, and the button lights

amber. When the transition completes, the button goes off.

CUT button: Pressing this button carries out the transition as a cut (i.e. instantaneously).

4 Wipe direction selection buttons

When you have selected a wipe or DME wipe as the transition type, press one of these buttons, turning it on, to select the wipe direction.

NORM (normal): The wipe proceeds in the direction from black to white as shown on the pattern in the lists of patterns (*see the appendixes “Wipe Pattern List” and “DME Wipe Pattern List” (Volume 2)*), or in the direction of the arrow.

When the VTR operation mode is enabled in setup, pressing this button plays the tape.

REV (reverse): The wipe proceeds in the opposite direction to that when the [NORM] button is pressed.

When the VTR operation mode is enabled in setup, pressing this button stops the tape.

NORM/REV (normal/reverse): The wipe direction alternates between normal and reverse every time a transition is executed.

When the VTR operation mode is enabled in setup, pressing this button cues the tape automatically to the start point.

5 TRANS PVW (transition preview) button

When this button is lit, you can check in advance the video changes during the transition, on the preview output from the M/E or PGM/PST bank.

During the preview, you can use the fader lever, [AUTO TRANS] button, and [CUT] button. One of the following functions of this button can be selected in a Setup mode.

- When the transition completes, the system returns to the normal mode.
- The transition preview mode is maintained while this button is pressed.
- Switching is made between the transition preview mode and normal mode every time this button is pressed.

6 Pattern limit buttons

PTN (pattern) LIMIT: Pressing this button, turning it on, enables the pattern limit function.

When the VTR operation mode is enabled in setup, pressing this button plays the tape.

LIMIT SET: Use this button to set a pattern limit when the [PTN LIMIT] button is off.

Move the fader lever to the position of a particular pattern size, and stop it there, then press this button to set the pattern limit range.

When the VTR operation mode is enabled in setup, pressing this button stops the tape.

7 Key status display

For each of keys 1 to 4, the corresponding ON indicator lights when the key is inserted. It also shows the priority (1 to 4) of each key.

8 PRIOR (priority) SET button

While this button is held down, you can set the key priority.

The setting mode when this button is pressed depends on whether or not the [KEY PRIOR] button is lit, as follows.

- When the [KEY PRIOR] button is off, the current key priority is set.
 - When the [KEY PRIOR] button is lit, the key priority after the next transition is set.
- Press the [KEY PRIOR] button as required, to switch between these two modes.

In either mode, hold down the [PRIOR SET] button, and press the button ([KEY1]



to [KEY4]) corresponding to the key you want to bring to the front.

9 KF (keyframe) button

When the VTR operation mode is enabled in setup, pressing this button cues the tape automatically to the start point.

The following controls are used as the independent key transition control block.

10 Key delegation buttons

These buttons delegate this independent key transition control block to a desired keyer. Press one of the [KEY1] to [KEY4] buttons ([DSK1] to [DSK4] in the PGM/PST bank), turning it on.

You can press more than one button to select two or more keyers.

11 Independent key transition type selection buttons

Press one of the following buttons, turning it on, to select the independent key transition type.

MIX: Faded in or out.

WIPE: Inserted or deleted with a wipe.

DME (DME wipe): Inserted or deleted with a DME wipe.

12 Independent key transition execution section

KEY1 ON to KEY4 ON (DSK1 ON to DSK4 ON in the PGM/PST bank)

buttons: Press the corresponding one of these buttons to cut key 1 to key 4 in or out instantaneously. When the key corresponding to the button appears in the final program output, the button lights red, and otherwise lights amber.

AUTO TRANS (transition) buttons:

These correspond to keys 1 to 4 from left to right; press one to carry out an auto transition. The transition rate for an independent key transition can be set in the numeric keypad control

block, in the Flexi Pad control block, or in a menu.

13 Key source name display/key snapshot buttons

These display the source name selected on the corresponding keyer. In key snapshot mode, press these buttons, corresponding to registers 1 to 4 for the selected keyer, to save or recall a key snapshot.

14 Key snapshot setting buttons

K-SS (key snapshot): This enables key snapshot mode.

K-SS STORE (key snapshot store): To save a key snapshot, hold down this button, and press the key source name display/key snapshot button corresponding to the register you want to save.

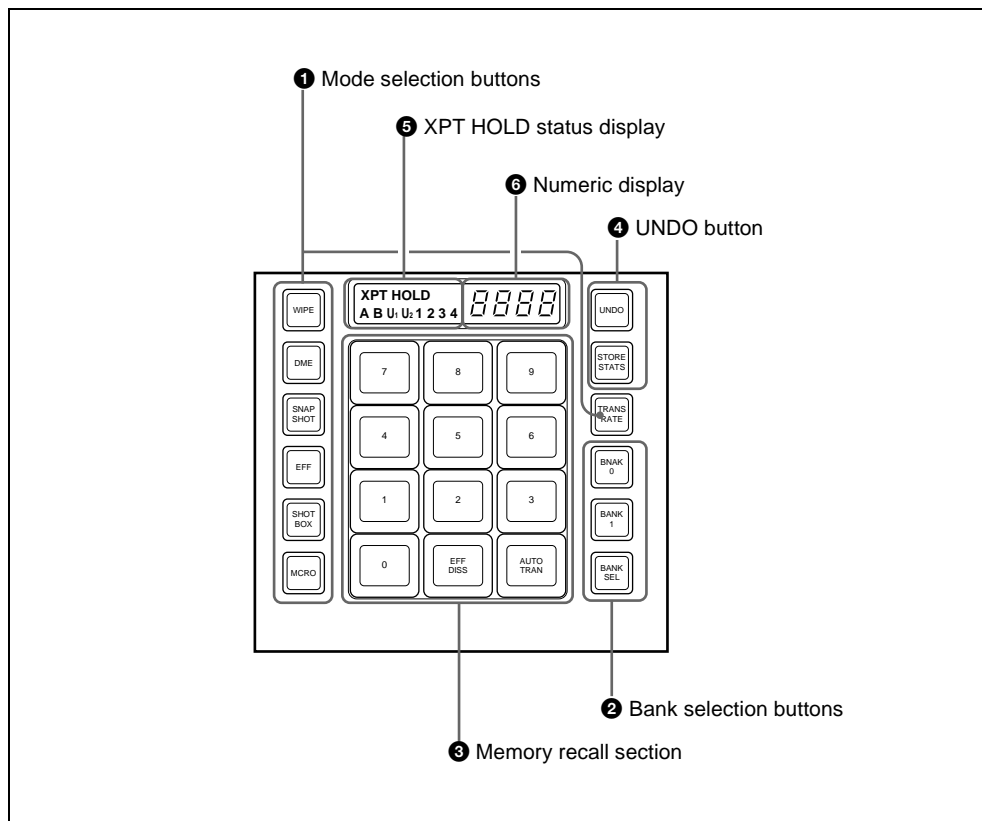
K-MOD ENBL (key modifier enable): To recall key adjustment values and key modifier settings when recalling a key snapshot, press this button, turning it on.

K-TR ENBL (key transition enable): To recall independent key transition settings when recalling a key snapshot, press this button, turning it on.

Flexi Pad Control Block (Standard Type)

The Flexi Pad control block is used for saving and recalling wipe snapshots, DME wipe snapshots, and snapshots, for recalling

effects, and shotbox content, and for entering the transition rate.



1 Mode selection buttons

WIPE: To save or recall a wipe snapshot, or recall the pattern number of a wipe pattern, use this in combination with the buttons of the memory recall section.

DME: To save or recall a DME wipe snapshot, or recall the pattern number of a DME wipe pattern, use this in combination with the buttons of the memory recall section.

SNAPSHOT: To save or recall a snapshot, use this in combination with the buttons of the memory recall section.

EFF (effect): To recall or run an effect, use this in combination with the buttons of the memory recall section.

SHOTBOX: To recall or execute a shotbox, use this in combination with the buttons of the memory recall section.



MCRO (macro): To save, recall or edit a macro, use this in combination with the buttons of the memory recall section.

TRANS RATE (transition rate): To enter the transition rate, press this button, turning it on. To enter the independent key transition rate, hold down this button, and press the key delegation button in the independent key transition control block. To select whether the value is entered in frames or as a timecode value, switch the [TC] button in the memory recall section on or off.

2 Bank selection buttons

BANK0 (bank 0): Assigns the memory recall section to bank 0, of registers 1 to 10.

BANK1 (bank 1): Assigns the memory recall section to bank 1, of registers 11 to 20.

BANK SEL (bank selection): After pressing this button, press a button in the memory recall section to select banks 0 to 9.

3 Memory recall section

This consists of 12 buttons with LCDs. These display changes, according to various operation modes.

4 UNDO button

UNDO: After recalling a register, press this button to return to the state before recalling the register.

When contents have been saved to a register or the contents of the register have been deleted, hold down the [STORE STATS] button and press this button to return the register to its state before the save or delete operation.

STORE STATS (store status): When a save or delete operation has been carried out on a register, this button lights amber. After saving to a register,

hold down this button and press the relevant register button to delete the data in the register. Again, after a save or delete operation on a register, hold down this button and press the [UNDO] button to restore the register to its state before the save or delete operation.

5 XPT HOLD (cross-point hold) status display

A bus for which cross-point hold is set appears as a green light.

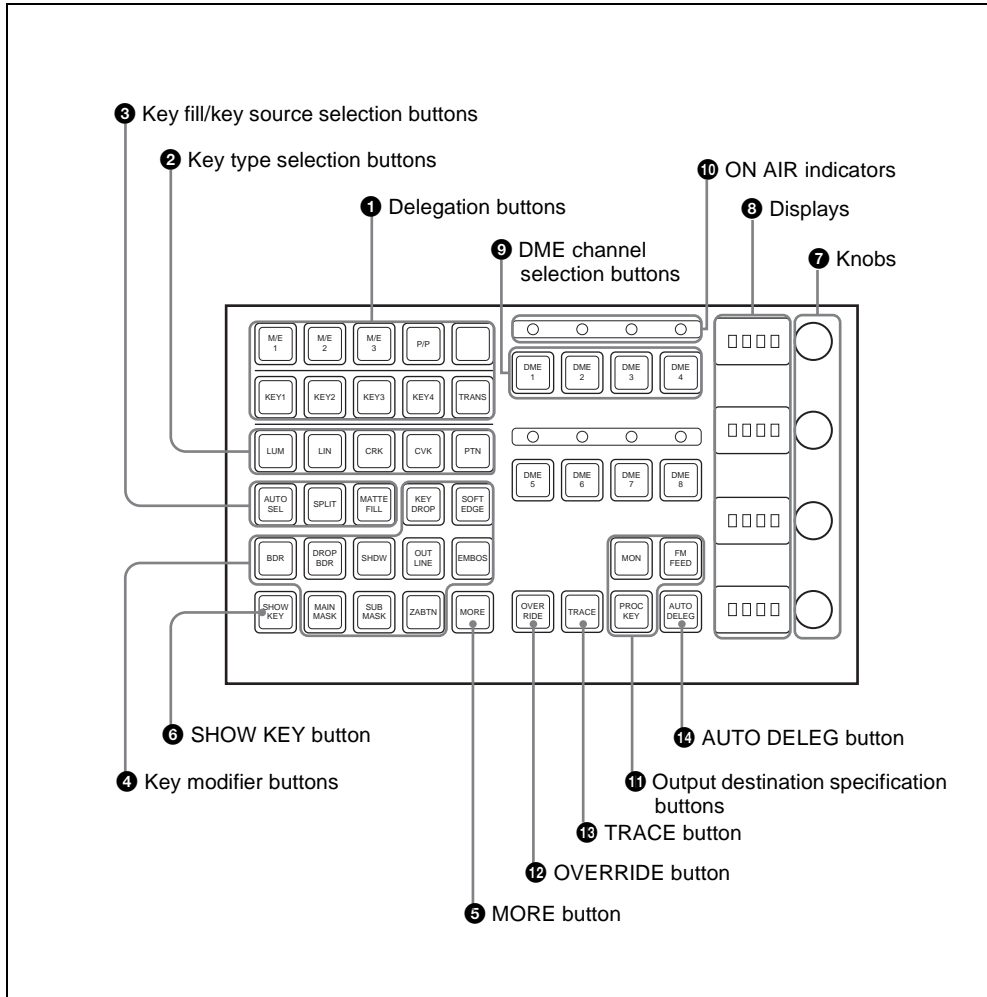
6 Numeric display

Depending on the operation mode, this shows the pattern number of a wipe or DME wipe, a bank number, a register number, a transition rate, and so on in up to four digits.

Key Control Block

Each of the M/E banks and the PGM/PST bank includes four keyers (for keys 1 to 4), and you can delegate this control block to

any desired keyer. In this control block, you can adjust and modify keys.



1 Delegation buttons

Key delegation: Press one of the [KEY1] to [KEY4] buttons to delegate the key control block to the corresponding keyer.

M/E delegation: Press one of the [M/E 1] to [M/E 3], and [P/P] buttons to select the bank (an M/E bank or the PGM/PST bank) to which the key control block is delegated.



TRANS: By pressing this button, you can check the DME channel used for DME wipes on the M/E or PGM/PST bank. Also, by pressing this button, then pressing one of the DME channel selection buttons, you can preset the DME channel to be used when a DME wipe is selected as the transition type for the next transition.

When presetting the DME channel for an independent key transition, hold down this button, then press one of the [KEY1] to [KEY4] buttons, turning the two buttons on, beforehand.

② Key type selection buttons

Press one of these buttons, turning it on, to select the desired key type.

Depending on the selected key type, various parameters are displayed, and you can set the values with the knobs.

LUM (luminance key): The background is cut out according to the luminance (Y) of the key source signal, and at the same time the key fill signal is cut out and then added to the background signal.

LIN (linear key): This is a type of luminance key with a reduced variation in gain and a higher adjustment precision.

CRK (chroma key): A particular hue (usually blue) in the key source signal is used to determine the hole to be cut in the background and filled with the key fill signal.

CVK (color vector key): The background is cut out with a key source created by adding the luminance and chrominance components of the key signal. If the saturation is high, this allows perfect keying even if the luminance level is low and the signal is not suitable for luminance keying.

PTN (wipe pattern key): A hole is cut in the background by a wipe pattern

selected in the transition, and this is filled with the key fill signal.

③ Key fill/key source selection buttons

AUTO SEL (selection): Use the signal selected on the key fill bus, and the paired key source signal. The setting of key fill and key source pairs is carried out in a Setup menu.

SPLIT: To use the signal selected on the key fill bus as key fill, and a signal separate from the signal assigned in a pair with key fill for key source, press this button, turning it on.

To select the signal on the key source bus, hold down this button, and press a button in the key 1 or key 2 row in the cross-point control block.

To use the signal selected on the key fill bus as key source (self keying), press the [AUTO SEL] button and [SPLIT] button at the same time, so that both are off.

MATTE FILL: To use a color matte from the internal generator as key fill, press this button, turning it on. You can adjust the color matte using the knobs. When this button is off, the signal selected on the key fill bus is used as key fill.

④ Key modifier buttons

To add an edge modifier to the key, press one of these buttons, turning it on.

Depending on the edge type selected, parameters appear in the displays, and you can set the values with the knobs.

KEY DROP: When drop border or shadow is selected, turning this button on lowers the key fill and key source position by four or eight scan lines as set in the key menu.

To select 4H or 8H, use the Key menu. When the selected edge type is “normal” and soft edge is selected or when border, outline, or emboss is

selected, this button lights automatically.

BDR (border): Apply a border of a uniform thickness to the whole key.

DROP BDR (drop border): Apply a border to two sides of the key (for example, below and to the right, or below and to the left).

SHDW (shadow): Apply a shadow to two sides of the key (for example, below and to the right, or below and to the left).

OUTLINE: Use the outline of the key.

EMBOS (emboss): Apply an embossing effect to the periphery of the key.

- To select a “normal” as the edge type (that is, a plain edge), set all five of the above buttons off.
- When border, drop border, or shadow is selected, you can use a special color matte or a signal selected on the utility 1 bus for the edge.
- When emboss is selected, you can use the dedicated color matte signal for the emboss function.
- When outline is selected, the signal selected on the key fill bus is used to fill the edge.

MAIN MASK: Press this button, turning it on, to enable the key mask using the main pattern. It also enables you to set the parameters with the knobs.

SUB MASK: Press this button, turning it on, to enable the key mask using the sub pattern. It also enables you to set the parameters with the knobs.

ZABTN (zabton): When this is pressed, turning it on, a translucent pattern is inserted behind the key. With the knobs, you can adjust the color, size, density, and softness parameters.

SOFT EDGE: Soften the edge of the key.

5 MORE button

When there are more than four parameters, this button lights amber. When it is pressed,

it changes from amber to green and the fifth and subsequent parameters are assigned to the knobs, allowing them to be adjusted.

6 SHOW KEY button

While this button is held down, a key processed key source signal is output from the specified output port. You can make the output specification independently for each of edit preview and the preview of each M/E or PGM/PST bank in a Setup menu.

7 Knobs

Turn the knobs to adjust the parameter values.

8 Displays

Each display shows the initial letters of the parameter name and the parameter value (maximum three digits including a minus sign for a negative value).

9 DME channel selection buttons

Press one of these buttons, turning it on, to delegate a DME channel to the keyer. The number of valid DME channel selection buttons depends on the number of channels installed in the DME processor.

A maximum of three consecutively numbered DME channels among DME 1 to 4 can be assigned to one keyer. A DME channel assigned to a keyer cannot be selected on another keyer. However, using the override function it is possible to allocate a channel already allocated to another keyer to the currently selected keyer. Using the trace function, it is possible to check which keyer a DME channel is allocated to.

10 ON AIR indicators

These light red when the corresponding DME channels are included in the final program output.





11 Output destination specification buttons

MON (monitor): Hold down this button and press the selection button for the DME channel you want to assign to the monitor output; you can then monitor the output signal on the DME monitor output.

While this button is held down, the DME channel selection buttons light as follows, allowing you to check the monitor assignment.

Lit amber: DME channel that can currently be monitored

Lit green: DME channel currently assigned to the monitor output

FM FEED (frame memory feed): When you press this button, it lights momentarily amber, then for the currently selected keyer, the key processed signals are selected for frame memory sources 1 and 2. If a DME is selected on the currently selected keyer, the key fill and key source signals to which a DME effect is applied are assigned to frame memory sources 1 and 2; otherwise the key fill and key source are assigned.

Carrying out a frame memory feed causes the [PROC KEY] button to light amber.

PROC KEY (processed key): When this button is on, the key fill/source signal subjected to key processing or signal subjected to a DME effect on the currently selected keyer can be selected as a reentry signal (PROC V or PROC K) for the M/E or PGM/PST bank, on the auxiliary bus or the like.

12 OVERRIDE button

To select a DME channel already allocated to another keyer or transition to the currently selected keyer (or transition), hold down this button, and press the DME channel selection button.

13 TRACE button

When a DME channel is already allocated to another keyer or transition, hold down this button, and press the corresponding DME channel selection button, to switch to the state in which the keyer (or transition) to which the DME channel is allocated is currently selected.

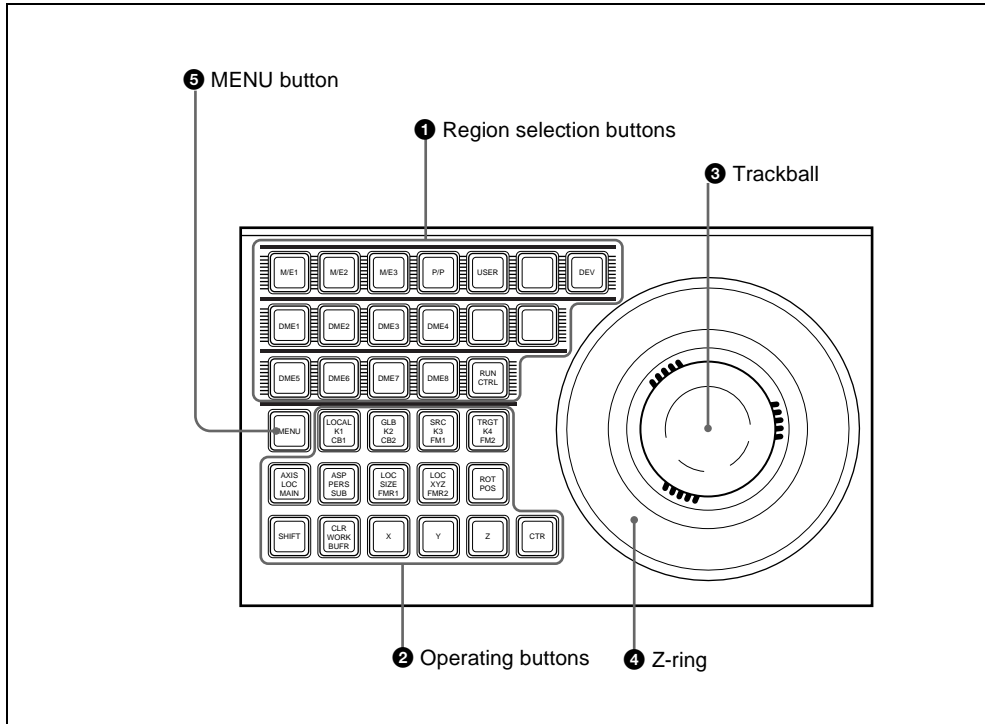
14 AUTO DELEG (auto delegation) button

When this button is on, the key delegation selection state of the key control block is linked to the key delegation selection state of the independent key transition control block.

Device Control Block (Trackball)

The device control block is used for three-dimensional transform operations using a

DME, for wipe pattern position setting, and for VTR operation.



1 Region selection buttons

The operation mode allocated to the device control block depends on the selection state of the region selection buttons.

When the [M/E 1], [M/E 2], [M/E 3], and [P/P] buttons are selected: This enables the wipe pattern position setting (positioner) operation mode in the device control block. You can select multiple buttons simultaneously.

When the [USER] button is selected: This enables pattern position setting used for color backgrounds.

When the [DME 1] to [DME 4] buttons are selected: This enables the three-dimensional transform operation mode

in the device control block.

Press a button, turning it on, to select a DME channel. You can select multiple buttons simultaneously.

The number of valid buttons depends on the number of DME processor channels installed.

When the [DEV] button is selected: This enables the VTR operation mode in the device control block. In this state, the [M/E 1] to [M/E 3] buttons, P/P button and DME1 to DME8 buttons function as the device 1 to device 12 allocation buttons as follows.

M/E1 (DEV1): device 1

M/E2 (DEV2): device 2

M/E3 (DEV3): device 3
P/P (DEV4): device 4
DME1 (DEV5): device 5
DME2 (DEV6): device 6
DME3 (DEV7): device 7
DME4 (DEV8): device 8
DME5 (DEV9): device 9
DME6 (DEV10): device 10
DME7 (DEV11): device 11
DME8 (DEV12): device 12

To exit from this mode, press the [DEV] button again, turning it off.

When the [RUN CTRL] button is selected: This enables the effect run control mode in the device control block.

The functions of the operation buttons, trackball, and Z-ring vary with the operation mode as follows.

② Operation buttons

When the positioner operation mode is enabled

K1 CB1: Press this button to enable wipe pattern position setting for key 1 (DSK1).

When the [USER] button is selected, pattern position setting for color background 1 is enabled.

K2 CB2: Press this button to enable wipe pattern position setting for key 2 (DSK2).

When the [USER] button is selected, pattern position setting is enabled for color background 2.

K3 FM1: Press this button to enable wipe pattern position setting for key 3 (DSK3).

K4 FM2: Press this button to enable wipe pattern position setting for key 4 (DSK4).

MAIN: Press this button to enable main wipe pattern position setting for normal transitions.

SUB: Press this button to enable sub wipe pattern position setting for normal transitions.

Among the [K1 CB1] button, [K2 CB2] button, [K3 FM1] button, [K4 FM2] button, [MAIN] button, and [SUB] button, you can make a multiple selection.

POS: Press this button to enable pattern movement in the x-axis and y-axis directions with the trackball. When the [USER] button is selected, this enables the trackball to move the pattern in the x-axis and y-axis directions, and the Z-ring to adjust the size of the pattern.

X, Y: These restrict the axes affected by the trackball and Z-ring to the x- or y-axis.

Z: This restricts the axes affected by the trackball and Z-ring to the z-axis.

CTR (center): When this button is pressed, the pattern position returns to the center. When the [USER] button is selected, the pattern size also returns to 50.00.

SHIFT/CLR WORK BUFR: These are not used in positioner operation mode.

When the three-dimensional transform operation mode is enabled

LOCAL: Enable operations in the DME local coordinate space.

GLB (global): Enable operations in the DME global coordinate space.

The [LOCAL] and [GLB] buttons can be selected at the same time.

SRC (source): Enable operations in the DME source coordinate space.

TRGT (target): Enable operations in the DME target coordinate space.

The [SRC] and [TRGT] buttons cannot be selected at the same time.

AXIS LOC (location): When this button is lit, the trackball moves the rotational

axis of the image in the x- and y-directions, and the Z-ring moves the axis in the z-direction.

ASP PERS (aspect/perspective): When the [SRC] button is lit, pressing this button enables the trackball to control the x- and y-directions independently, and the Z-ring controls the x- and y-directions together, to vary the aspect ratio. When the [SHIFT] button is held down and this button is pressed, the trackball controls the skew of the image in the x- and y-directions. When the [TRGT] button is lit, pressing this button enables the trackball to control the perspective of the image in the x- and y-directions. The Z-ring controls the distance to the viewpoint.

LOC (location) SIZE: When this button is lit, the Z-ring controls the image size. The trackball moves the image in the x- and y-directions.

LOC (location) XYZ: When this button is lit, the trackball moves the image in the x- and y-directions, and the Z-ring moves the image in the z-direction.

SHIFT: While holding down this button, pressing the [ASP PERS] button or [ROT] button switches to the shifted version of the corresponding function.

CLR WORK BUFR (clear work buffer): Press this button once to clear only the three-dimensional transform parameters of the information held in the work buffer. Press twice in rapid succession to clear all of the parameters, and return to the default state.

ROT (rotation): When this button is lit, the trackball rotates the image about the x- and y-axes, and the Z-ring rotates the image about the z-axis. Pressing this while holding down the [SHIFT] button enables rotation of the

image in the “Spin” mode. The trackball and Z-ring operate in the same manner.

X, Y, Z: These restrict which axes the trackball and Z-ring can control. You can select more than one.

When one of these buttons is selected, you can enter the parameter value for the corresponding axis using the numeric keypad control block.

CTR (center): Pressing this button changes the values of the three-dimensional parameters currently controlled by the trackball and Z-ring to the closest detent values. Pressing twice in rapid succession returns the parameter values to their defaults.

When the VTR operation mode is enabled

LOCAL (DELAY): Press this button, turning it on, to enter a delay value from the numeric keypad control block.

GLB (STB OFF: standby off): Press this button to switch to standby off mode.

SRC (REC: record): Press this button at the same time as the [Y] button to record on the VTR.

TRGT (STOP): Press this button to stop the tape.

AXIS LOC (START TC: start timecode): Press this button to set the timecode of the start point. Each time you press the button, the start point changes.

ASP PERS (STOP TC: stop timecode): Press this button to set the timecode of the stop point. Each time you press the button, the stop point changes.

LOC SIZE (VAR: variable speed playback): Pressing this button and turning the Z-ring plays back the tape at a variable speed and direction proportional to the rotation angle of the



Z-ring. The variable speed range is -1 to +3 times normal playback speed.

LOC XYZ (SHTL: shuttle): Pressing this button and turning the Z-ring plays back the tape at a speed and direction proportional to the rotation angle of the Z-ring.

ROT (JOG): Pressing this button and turning the Z-ring plays back the tape at a speed and direction proportional to the rotation speed and direction of the Z-ring.

CLR WORK BUFR (CUE): Pressing this button cues the tape automatically to the start point.

X (REW: rewind): Press this button to rewind the tape.

Y (PLAY): Press this button to play the tape.

Z (FF): Press this button to fast-forward the tape.

CTR (ALL STOP): Press this button to stop all tape transport operations.

③ Trackball

When the positioner operation mode is enabled

By moving this, you can move the pattern in the x-axis and y-axis directions.

When the three-dimensional transform operation mode is enabled

Move the trackball to control the x- and y-axes in a three-dimensional transform.

④ Z-ring

When the positioner operation mode is enabled

When the [USER] button is selected, by turning the ring you can adjust the size of the pattern.

When the three-dimensional transform operation mode is enabled

Turn this ring to control the z-axis in a three-dimensional transform.

When the effect run control mode is enabled

By turning the Z-ring, you can run the keyframe effect, independent of the STOP NEXT KF, EFF LOOP, and similar settings in the keyframe control block. Turn clockwise to run the effect in the normal direction, and counterclockwise for the reverse direction.

When the VTR operation mode is enabled

Turning the Z-ring controls the tape transport, at a speed determined by the operating buttons. Turn clockwise for the normal direction, and counterclockwise for the reverse direction.

⑤ MENU button

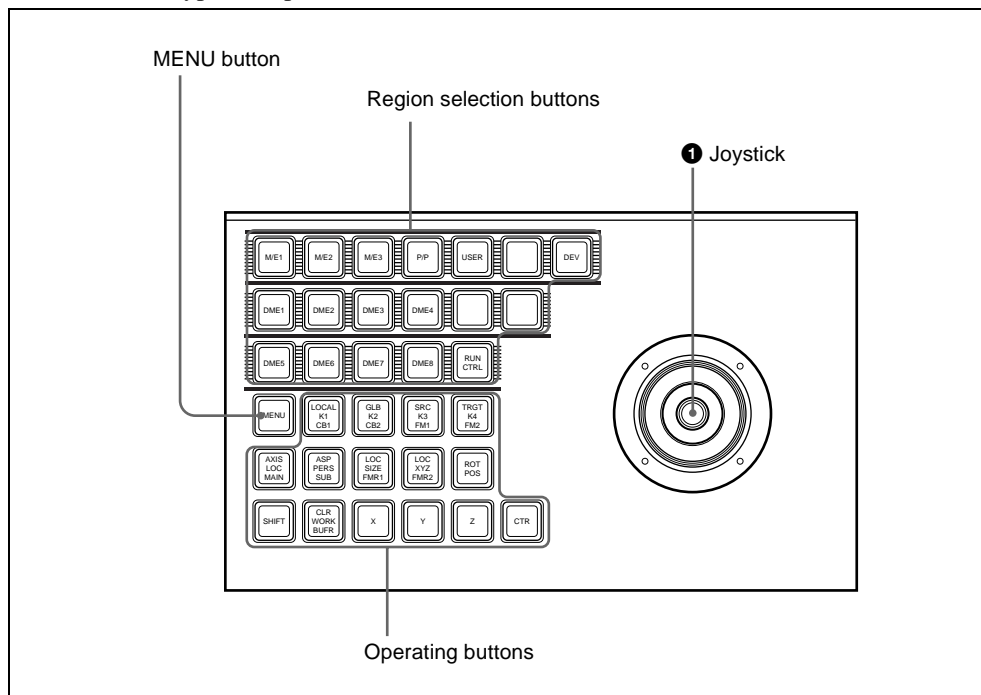
Press this button, turning it on, to enable adjusting the parameters allocated to the knobs in the menu using the trackball and Z-ring.

In the case of the DME menu, the operation applies to the selected DME channel.

Device Control Block (Joystick)

All functions of the joystick type device control block are equivalent to the functions of the trackball type, except that the

trackball and Z-ring operations are carried out with the joystick.



1 Joystick

By moving this, you can carry out operations in the x-, y-, and z-axes.

When the effect run control mode is enabled

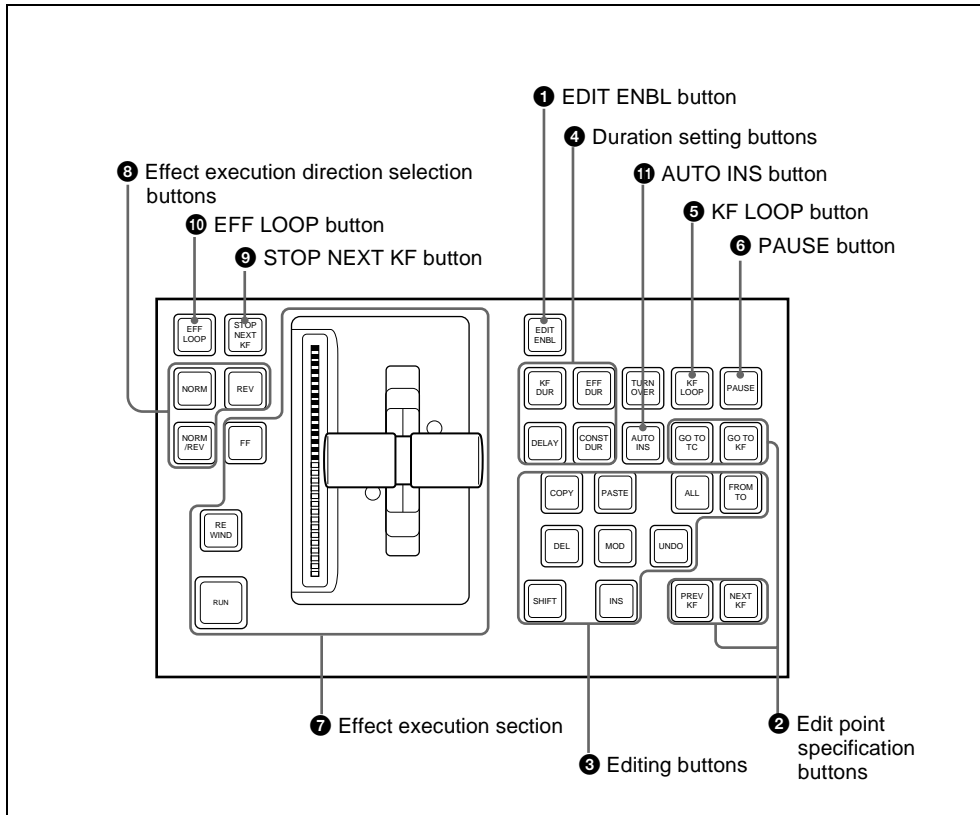
By moving the joystick sideways, you can run the keyframe effect, independent of the STOP NEXT KF, EFF LOOP, and similar settings in the keyframe control block. Move to the right to run the effect in the normal direction, and to the left for the reverse direction.

When the VTR/disk recorder operation mode is enabled

Moving the joystick sideways controls the tape transport/disk operation, at a speed determined by the operating buttons. Move to the right for the normal direction, and to the left for the reverse direction.

Keyframe Control Block

In the keyframe control block, you can carry out effect editing and execution.



1 EDIT ENBL (edit enable) button
Press this button, turning it on, to enable effect editing operations with the keyframe control block.
When macro editing is carried out, this button lights red,

2 Edit point specification buttons
GO TO TC (Go to timecode): Press this button, turning it on, to enter a numeric value from the numeric keypad control block, and move the edit point to the specified timecode position.

GO TO KF (Go to keyframe): Press this button, turning it on, to enter a numeric value from the numeric keypad control block, and move the edit point to the specified keyframe.

PREV KF (previous keyframe): When this button is pressed, the edit point moves to the keyframe immediately before the current time (the position where the effect is currently stopped).

NEXT KF (next keyframe): When this button is pressed, the edit point moves

to the keyframe immediately after the current time.

3 Editing buttons

ALL: Press this button, turning it on, to select all keyframes in the effect.

FROM TO: Press this button, turning it on, to enter numeric values from the numeric keypad control block, and select a specified range of keyframes.

INS (insert): When this button is pressed, a new keyframe is inserted after the current keyframe. Pressing this button while holding down the [SHIFT] button inserts a new keyframe before the current keyframe.

MOD (modify): When this button is pressed, the selected keyframe is modified with the values of the current keyframe. When the edit point is between two keyframes, the immediately preceding keyframe is modified. You can also select multiple keyframes, and modify them in a single operation. At this time, pressing this button while holding down the [SHIFT] button modifies all selected keyframes with the changed values taken as relative values.

DEL (delete): When this button is pressed, the selected keyframe is deleted. When the edit point is between two keyframes, the immediately preceding keyframe is deleted. You can also select multiple keyframes, and delete them in a single operation.

COPY: When this button is pressed, the selected keyframe is copied. You can also select multiple keyframes, and copy them in a single operation.

PASTE: When this button is pressed, the deleted or copied keyframe is inserted after the current keyframe. Pressing this button while holding down the [SHIFT] button inserts the deleted or

copied keyframe before the current keyframe.

SHIFT: Hold down this button, and press the [INS] button, [MOD] button, or [PASTE] button, to obtain the shifted function for the button.

UNDO: When this button is pressed, the last executed keyframe insertion, modification, or deletion, or paste operation is canceled.

4 Duration setting buttons

KF DUR (keyframe duration): Press this button, turning it on, to set the keyframe duration of the selected keyframe, by numeric value entry from the numeric keypad control block.

EFF DUR (effect duration): Press this button, turning it on, to set the effect duration from the numeric keypad control block.

DELAY: Press this button, turning it on, to enter a delay value from the numeric keypad control block.

CONST DUR (constant duration): Select the duration mode. When this is lit, the mode is constant duration mode, and when off, variable duration mode.

5 KF LOOP (keyframe loop) button

Press this button, turning it on, to execute the effect the specified number of times through the keyframes in the specified range.

6 PAUSE button

When this button is pressed, a pause is applied to the selected keyframe. When editing a macro, press this button, turning it on, to include a pause event in the macro. The pause length can be set in the numeric keypad control block.

7 Effect execution section

RUN: When this button is pressed, the effect is run from the first keyframe to

the last keyframe. However, if a pause is set on a keyframe, the effect stops at that point. Press this button again to resume execution, and continue to the next pause point or the end of the effect.

Effect indicator: This consists of 30 LEDs, and shows the progress of the effect.

Fader lever: Moving this up or down manually runs the effect.

REWIND: When this button is pressed, the currently recalled effect is rewound to the first keyframe.

FF (fast forward): When this button is pressed, the currently recalled effect is advanced to the last keyframe.

8 Effect execution direction selection buttons

NORM (normal): When this button is lit, effect execution runs from the first keyframe to the last keyframe.

REV (reverse): When this button is lit, effect execution runs from the last keyframe to the first keyframe.

Pressing one of these buttons automatically turns the other off.

NORM/REV (normal/reverse): Press this button, turning it on, to reverse the direction of the effect when it reaches the last keyframe or first keyframe.

9 STOP NEXT KF (stop next keyframe) button

When this button is pressed, turning it on, the effect execution range is from the current time to the next keyframe.

10 EFF LOOP (effect loop) button

When the effect reaches the last keyframe with this button on, it returns to the first keyframe and repeats.

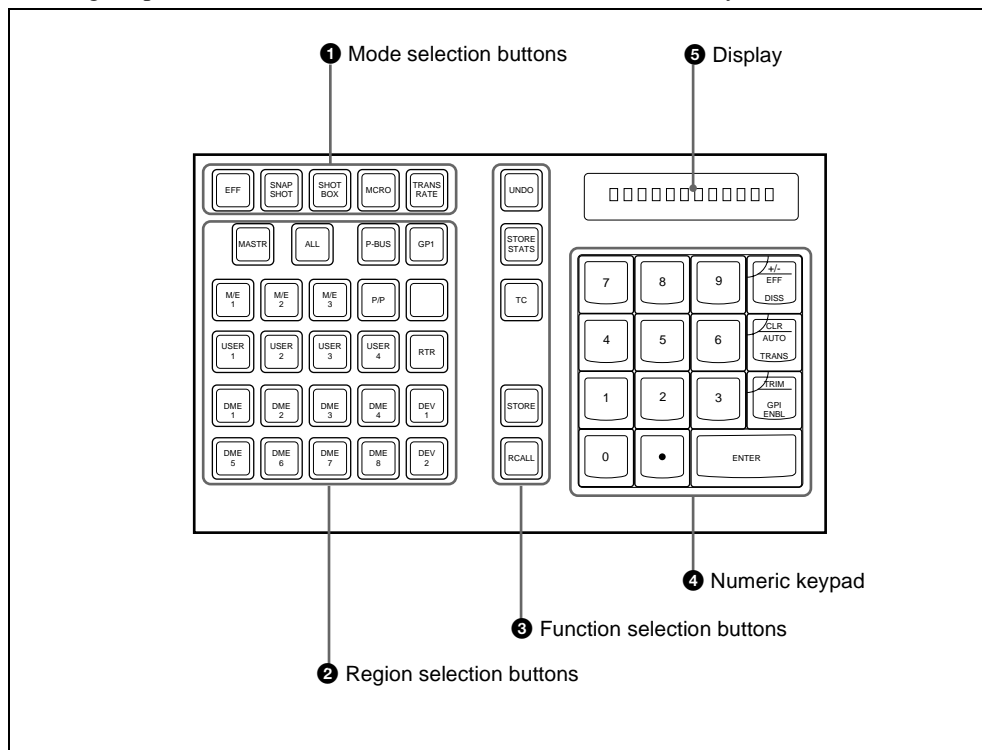
11 AUTO INS (auto insert) button

When editing a macro, press this button, turning it on, to enable the auto insert function, so that every control panel operation you carry out is added to the macro as an event.

Numeric Keypad Control Block

The numeric keypad control block is used for region selection, for saving and recalling snapshots, effects and shotboxes,

for entering numeric values for trackball operation and keyframe operation, and for transition rate entry.



1 Mode selection buttons

EFF (effect): Press to save or recall an effect.

SNAPSHOT: Press to save or recall a snapshot.

SHOTBOX: Press to save or recall a shotbox.

MCRO (macro): Press to save, recall or edit a macro.

TRANS RATE (transition rate): Press to set the transition rate. Hold down this button, and press one of the key delegation buttons [KEY1] to [KEY4]

in the transition control block to set an independent key transition rate.

2 Region selection buttons

These select the functional block (“region”) of the control panel to which operations apply.

You can select more than one region at the same time.

The first button you press is taken as the reference region, and lights green, while the next pressed button lights amber.

With the exception of the [MASTER] and [ALL] buttons, you can change the region



assignment to the buttons as desired in the Setup menu.

MASTR: Press this, turning it on, to save region information in a master snapshot register or master timeline register, or to recall such region information.

ALL: Select all regions. When any region is already selected, pressing this button makes all regions unselected.

M/E 1 to M/E 3, P/P: Select the corresponding regions, M/E-1, M/E-2, M/E-3, and PGM/PST.

USER 1 to USER 8: Select a USER region.

DME1 to DME4: Select a DME channel.

P-BUS: Select the P-BUS region.

GPI: Select the GPI region.

RTR:

DEV1 to DEV12: Select the device 1 to device 12 regions respectively.

③ Function selection buttons

UNDO: After recalling a register, press this button to return to the state before recalling the register.

STORE STATS (store status): This lights amber when data is stored in a register. After saving data to a register, hold down this button and press the [UNDO] button to return the register to the state before the data was saved.

TC (timecode): Press this button, turning it on, to switch transition rate entry to the timecode entry mode.

STORE: Press this button to switch to the mode for saving a snapshot, effect or shotbox in a register.

RCALL (recall): Press this button to switch to the mode for recalling a snapshot, effect, or shotbox from a register.

④ Numeric keypad

In addition to the buttons for numeric input, this includes buttons for adding attributes to snapshots.

0 to 9: Used to input numeric digits.

. (period): Enters the decimal point.

When the [TRANS RATE] button is lit, enters “00.” When the [EFF] button, [SNAPSHOT] button or [SHOTBOX] button is lit, this is used to find an empty register.

+/-/ EFF DISS (effect dissolve): Invert the sign, negative or positive.

When the [SNAPSHOT] button is lit, applies the effect dissolve attribute to a snapshot.

CLR/AUTO TRANS (clear/auto

transition): Clear an input value, returning to the previous state.

When the [SNAPSHOT] button is lit, applies the auto transition attribute to a snapshot.

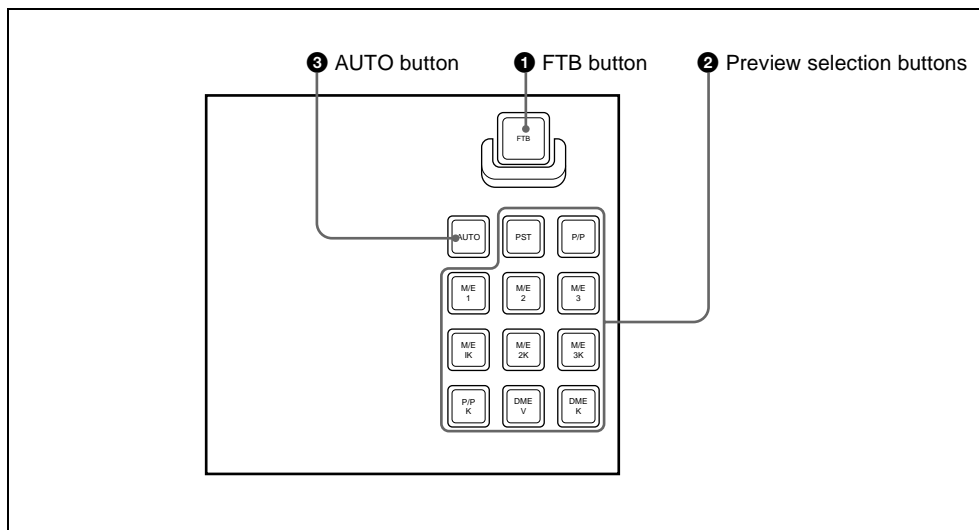
TRIM/GPI ENBL (enable): After entering a difference value to be added to an existing setting, press this button to confirm the change.

ENTER: Confirm an entered value.

⑤ Display

This shows the selected region name and entered numeric values.

Fade to Black Control Block



1 FTB (fade to black) button

Press this button to fade to black the program output of the PGM/PST bank, at the set transition rate. You can set the fade to black transition rate in the menu.

2 Preview selection buttons

Press one of these buttons to select a signal on the edit preview bus.

PST (preset): When this button is pressed, the signal selected on the background B row of the PGM/PST bank is selected on the edit preview bus.

M/E 1 to M/E 3, P/P (M/E1 to M/E 3, P/P preview): The preview signal (M/E-1 PVW, M/E-2 PVW, M/E-3 PVW, P/P PVW) of the M/E or PGM/PST bank corresponding to the pressed button is selected on the edit preview bus.

M/E1 K to M/E3 K, P/P K (M/E1 to M/E 3, P/P key preview): The key preview signal (M/E-1 K-PVW, M/E-2 K-PVW, M/E-3 K-PVW, P/P K-PVW) of the M/E or PGM/PST bank

corresponding to the pressed button is selected on the edit preview bus.

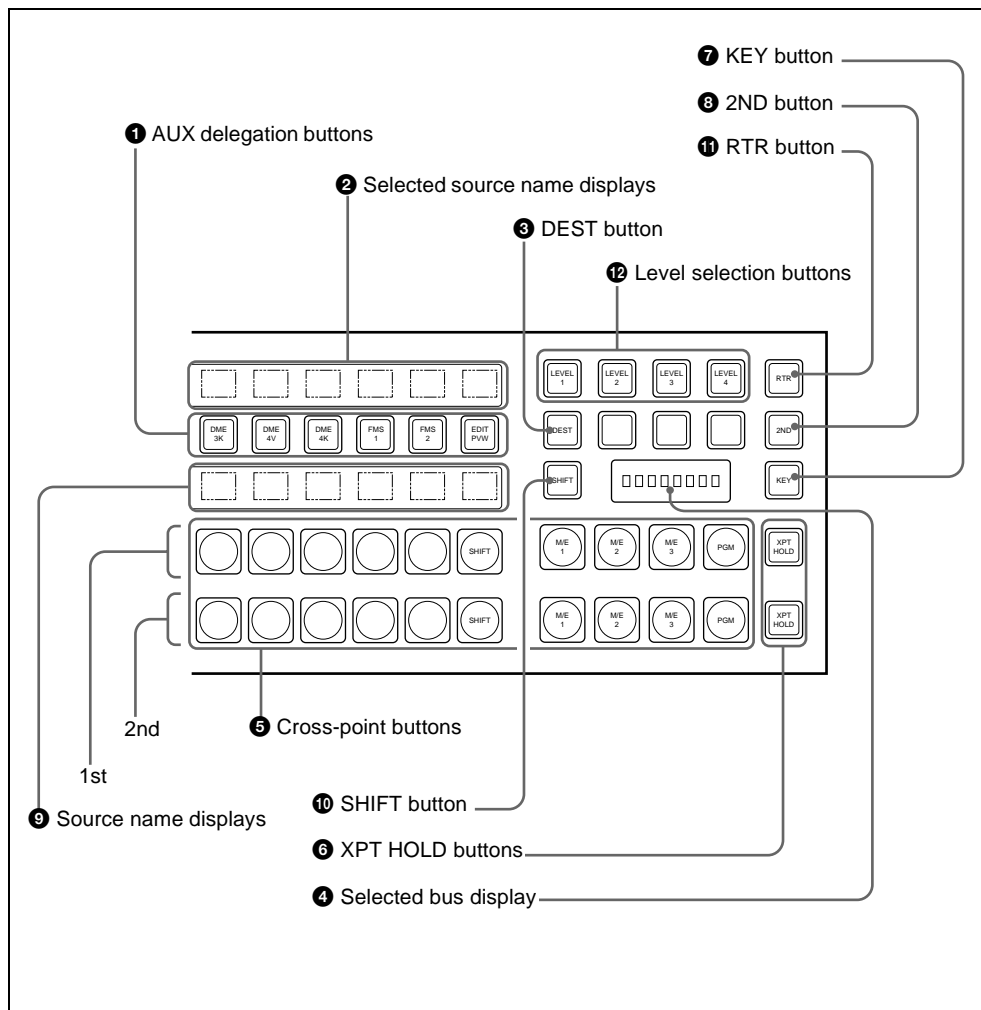
DME V (DME video): When this button is pressed, the DME monitor output video signal (DME MON V) is selected on the edit preview bus.

DME K (DME key): When this button is pressed, the DME monitor output key signal (DME MON K) is selected on the edit preview bus.

3 AUTO button

When this button is pressed, the M/E or PGM/PST bank preview signal selected on the edit preview bus is automatically switched to the program signal depending on the on-air status.

Auxiliary Bus Control Block



1 AUX delegation buttons

Press one of these buttons, turning it on, to select the bus to which to assign the cross-point buttons in the auxiliary bus control block.

The buses that can be selected are as follows.

- AUX buses 1 to 28
- MONITOR 1 to MONITOR 8
- FMS 1 (frame memory source 1) and FMS 2 buses
- DME 1V to DME 4V buses
- DME 1K to DME 4K buses
- EDIT PVW (preview) bus
- M/E-1 UTILITY 1 and M/E-1 UTILITY 2 buses
- M/E-2 UTILITY 1 and M/E-2 UTILITY 2 buses



- M/E-3 UTILITY 1 and M/E-3 UTILITY 2 buses
- P/P UTILITY 1 and P/P UTILITY 2 buses
- DSK 1 fill to DSK 4 fill buses
- DSK 1 source to DSK 4 source buses
- M/E-3 key 1 fill to M/E-3 key 4 fill buses
- M/E-3 key 1 source to M/E-3 key 4 source buses
- M/E-1 external DME bus
- M/E-2 external DME bus
- M/E-3 external DME bus
- P/P external DME bus
- DME UTILITY1 and DME UTILITY2 buses

2 Selected source name displays

These show the name of the currently selected signal (source) on the bus corresponding to the delegation button.

3 DEST (destination) button

Press this button, turning it on, to display the names of buses allocated to the delegation buttons in the selection source name displays.

4 Selected bus display

This shows the name of the bus selected by the auxiliary bus delegation buttons.

5 Cross-point buttons

The cross-points in the auxiliary bus control block are arranged in two rows: an upper row (1st row) and a lower row (2nd row), and are allocated to the buses selected with the AUX delegation buttons. The 1st row contains the cross-point buttons for unshifted buses, and the 2nd row contains the cross-point buttons for shifted buses. When the DME 1V/K to 4V/K buses are selected with the AUX delegation buttons, the 1st row cross-point buttons are for the currently showing side of DME, and the 2nd row are for the reverse side.

By holding down the [2ND] button and making an AUX delegation selection, you can allocate the 2nd row to a different bus from the 1st row.

In this case, if the 32nd button is set to be a [SHIFT] button (in a 32-button system), the cross-point buttons switch to the shifted allocation while the [SHIFT] button is enabled.

6 XPT HOLD (cross-point hold) buttons

Press one of these buttons, turning it on, to enable cross-point hold.

7 KEY button

While this button is held down, you can use the cross-point row of buttons to select key signals.

8 2ND button

After selecting a bus with an AUX delegation button, hold down this button, and select another AUX delegation, thus allocating a different bus in the 2nd row from the 1st row.

9 Source name displays

These show the names of the source signals which can be selected by the cross-point buttons. While the [SHIFT] button is enabled, the shifted signal name is displayed. If a different bus is allocated to the 2nd row, while the [2ND] button is held down, the 2nd row signal name is displayed.

While the [KEY] button is held down, the source name of the key signal assigned to the cross-point buttons appears.

10 SHIFT button

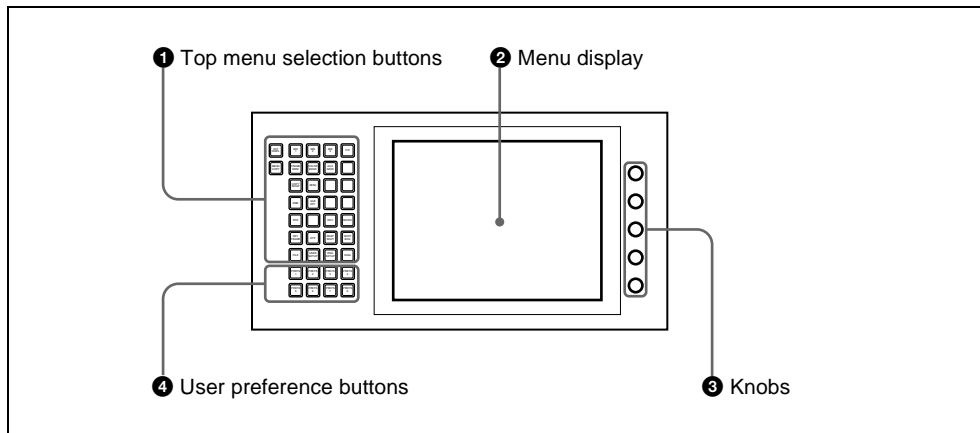
While this button is enabled, the shifted signal names appear in the source name display. Pressing this buttons toggles the source name display between the shifted signal names and unshifted signal names.

11 RTR button

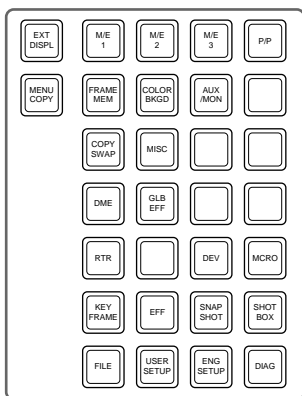
12 Level selection buttons



Menu Control Block



1 Top menu selection buttons
These select the menu appearing in the menu display.



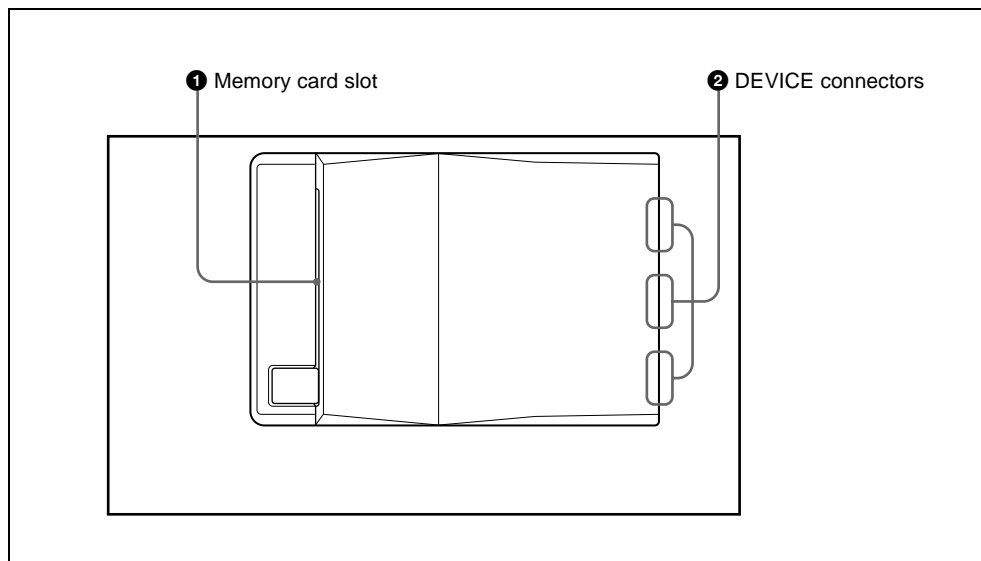
2 Menu display
This shows the menu currently in use.

3 Knobs
These adjust the parameter values appearing in the menu.

4 User preference buttons
These recall the functions or menus assigned to them in the Setup menu. In the default setup, nothing is assigned to the [PREFS 1] to [PREFS 7] buttons.

PREFS 8 button: When this button is on, control of an editor from the Remote1 port on the rear panel of the switcher is possible. However, even when it is off, control of the Edit PVW bus is always possible.

Memory Card/USB Adaptor Block



❶ Memory card slot

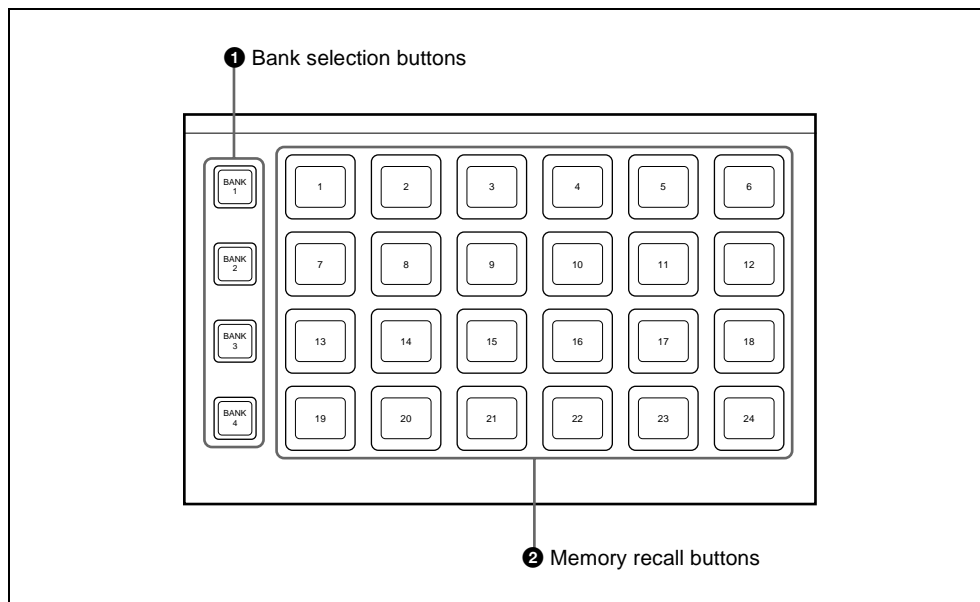
This slot accepts a PCMCIA Type II compliant memory card. You can use it in software installation, and for saving and reading in data, such as snapshot, keyframe, effect, and setup data.

❷ DEVICE connectors

There are three USB connectors. You can connect a device such as a mouse, keyboard, pen tablet, and so on, that is equipped with a USB interface to any of these connectors.

For details on the devices that can be connected, consult your Sony representative.

Utility/Shotbox Control Block



1 Bank selection buttons

Press any of the [BANK1] to [BANK4] buttons to select a bank of 24 memory recall buttons. The selected button lights amber.

2 Memory recall buttons

Use these by allocating a utility function or shotbox function.

When a utility function is allocated, the button lights orange (or green depending on the status), and the allocated function name appears. Pressing a button executes the allocated function. When the function constitutes a switching on/off operation, the button lights green; otherwise, it only momentarily lights green.

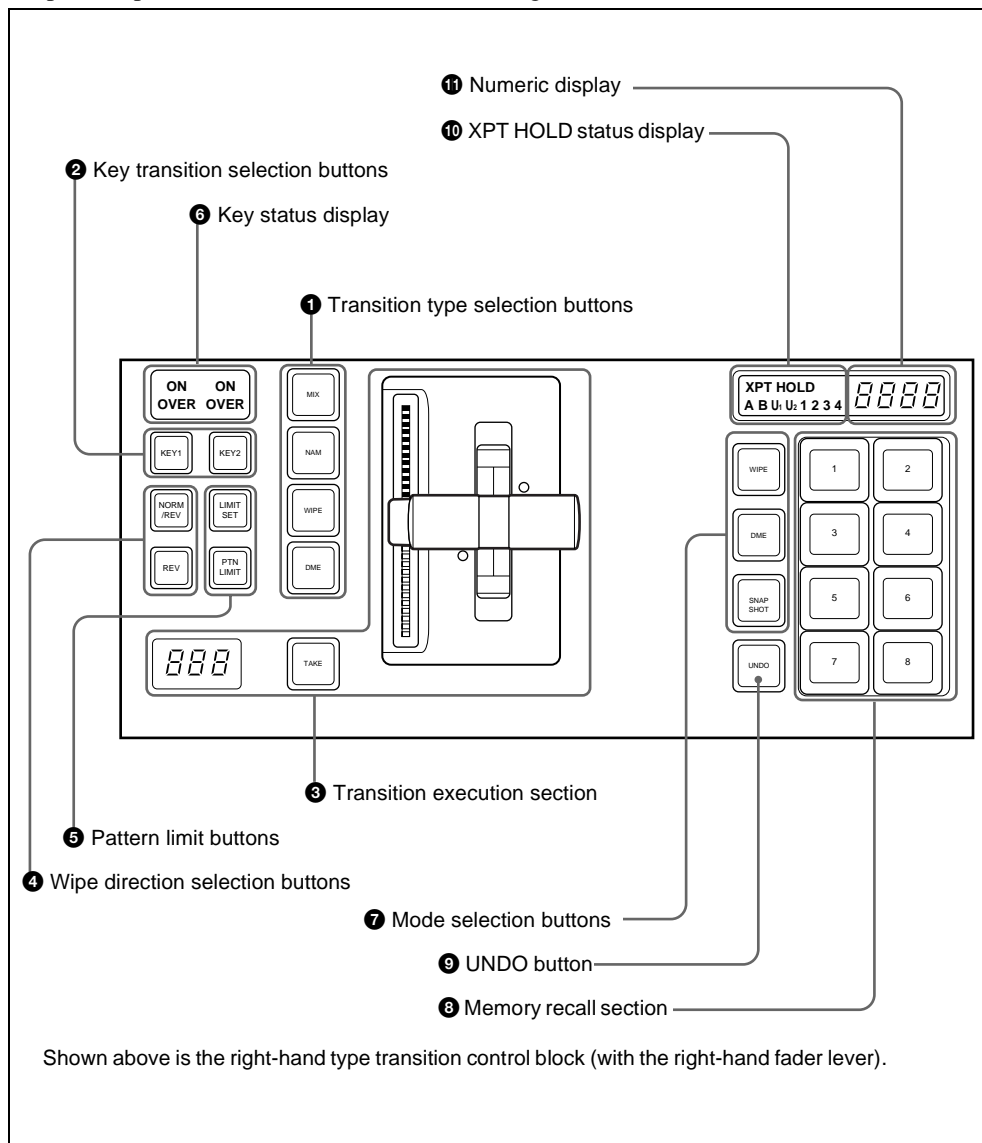
When a shotbox function is allocated, the button lights orange, and the name of the allocated register appears. (If the register is empty, the button goes off.) Pressing a button executes the allocated shotbox function, and the button lights yellow. If

there is a button immediately previously lit yellow, it changes to orange.

Transition Control Block and Flexi Pad Control Block (Simple Type)

The simple versions of the transition control block and Flexi Pad control block shown below is designed to allow simplified operations than with the standard

type. The transitions carried out using these simple-type control blocks are also referred to as “simple transitions” in this user’s guide.



1 Transition type selection buttons

Press one of these buttons, turning it on, to determine the type of the next transition for a background.

To select the key transition type, hold down the [KEY1] or [KEY2] button, and press one of the following buttons, turning it on. When multi-program mode is selected in the Setup menu (see “Settings for Switcher Configuration (Config Menu)” in Chapter 16 (Volume 2)), two or more of the following buttons may light.

MIX: In a background transition, the new video fades in as the current video fades out. During the transition, the overall signal level is maintained at 100%.

In a key transition, the key fades in (for insertion) or out (for removal).

NAM (non-additive mix): The current and new video signals are compared, and the signal with the higher luminance level is given priority in the output. The current video is maintained at 100% output for the first half of the transition as the new video increases progressively to 100%, then the current video is progressively reduced from 100% to zero in the second half while the new video is maintained at 100%.

WIPE: The current video is replaced by the new video, using the wipe pattern selected in the Wipe menu.

DME: This applies a wipe-like transition, using the DME effect selected in the DME Wipe menu.

2 Key transition selection buttons

To insert or delete key 1 on the next transition, hold down the [KEY1] button, and select the type of transition using the transition type selection buttons. If the key is currently not inserted, the transition will insert it, and if the key is currently inserted, the transition will delete it. You can use the [KEY2] button in a similar way.

3 Transition execution section

Fader lever: Move this vertically to carry out a transition.

When the split fader function is enabled, by pressing the projection on the left side of the grip you can release the lock and separate the two halves of the fader lever. With the split fader lever, in a background mix transition, you can control the background A and B buses independently.

Transition indicator: This comprises 30 LEDs, which show the progress of the transition.

Transition rate display: This displays the transition rate (the time from the beginning of the transition to its completion) set for an auto transition, in frames.

You can set the transition rate using the numeric keypad control block or menu.

TAKE button: Pressing this button carries out an auto transition of the set transition rate. The transition starts immediately, and the button lights amber. When the transition completes, the button goes off.

4 Wipe direction selection buttons

REV (reverse): When this button is off, the wipe proceeds in the normal direction. When the button is lit, the wipe proceeds in the reverse direction.

The normal direction refers to the black to white direction or in the direction of the arrow as shown in the appendixes “Wipe Pattern List” and “DME Wipe Pattern List” (Volume 2).

NORM/REV (normal/reverse): The wipe direction alternates between normal and reverse every time a transition is executed.

5 Pattern limit buttons

LIMIT SET: Move the fader lever to the position of a particular pattern size, and

stop it there, then press this button to set the pattern limit range. This button is enabled when the [PTN LIMIT] button is off.

PTN (pattern) LIMIT: When a wipe or DME wipe is selected, pressing this button, turning it on, enables the pattern limit function.

⑥ Key status display

For each of keys 1 and 2, when the key is inserted, the corresponding ON indicator lights. The OVER indicators show the priority between keys 1 and 2, by lighting when the corresponding key is on top. For example, when key 1 appears over key 2 on the program monitor, the OVER indicator for key 1 lights.

The following is the Flexi Pad control block.

⑦ Mode selection buttons

WIPE: When saving or recalling a wipe snapshot, use this in combination with the buttons of the memory recall section.

DME: When saving or recalling a DME wipe snapshot, use this in combination with the buttons of the memory recall section.

SNAPSHOT: When saving or recalling a snapshot, use this in combination with the buttons of the memory recall section.

⑧ Memory recall section

This consists of eight buttons with LCDs, whose display changes according to the operation mode. Use these in combination with the mode selection buttons to save, recall, or delete wipe snapshots, DME wipe snapshots, or snapshots.

⑨ UNDO button

After recalling a register, press this button to return to the state before recalling the register.

⑩ XPT HOLD (cross-point hold) status display

A bus for which cross-point hold is set appears as a green light.

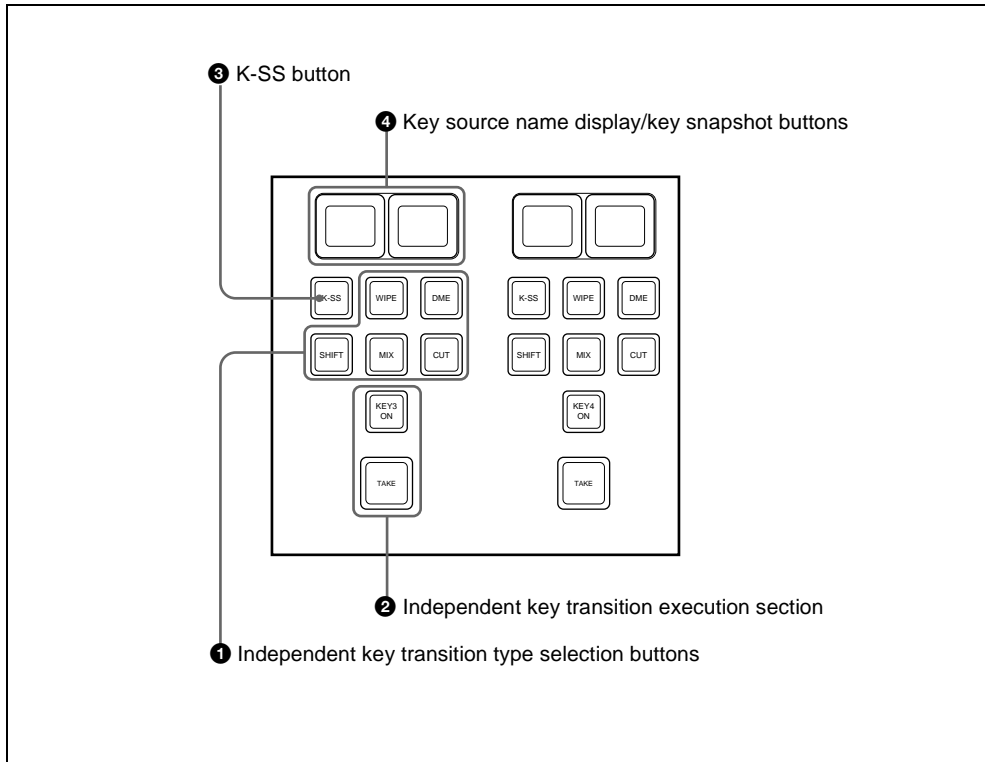
⑪ Numeric display

Depending on the operation mode, this shows a wipe or DME wipe pattern number, or a register number in up to four digits.

Independent Key Transition Control Block (Simple Type)

The left side of this control block controls key 3, and the right side controls key 4.

The control block for key 3 only is described as an example, but the operations on the key 4 control block are the same.



1 Independent key transition type selection buttons

Press one of the following buttons, turning it on, to select the independent key transition type.

MIX: Faded in or out.

WIPE: Inserted or deleted with a wipe.

DME: Switches the key with a DME wipe.

CUT: Inserted or deleted instantaneously.

SHIFT:

2 Independent key transition execution section

KEY3 ON button: This inserts or deletes key 3 instantaneously. When key 3 is present in the final program output from the switcher, this lights red, and otherwise lights amber.

TAKE button: This carries out an auto transition on key 3.

3 K-SS (key snapshot) button

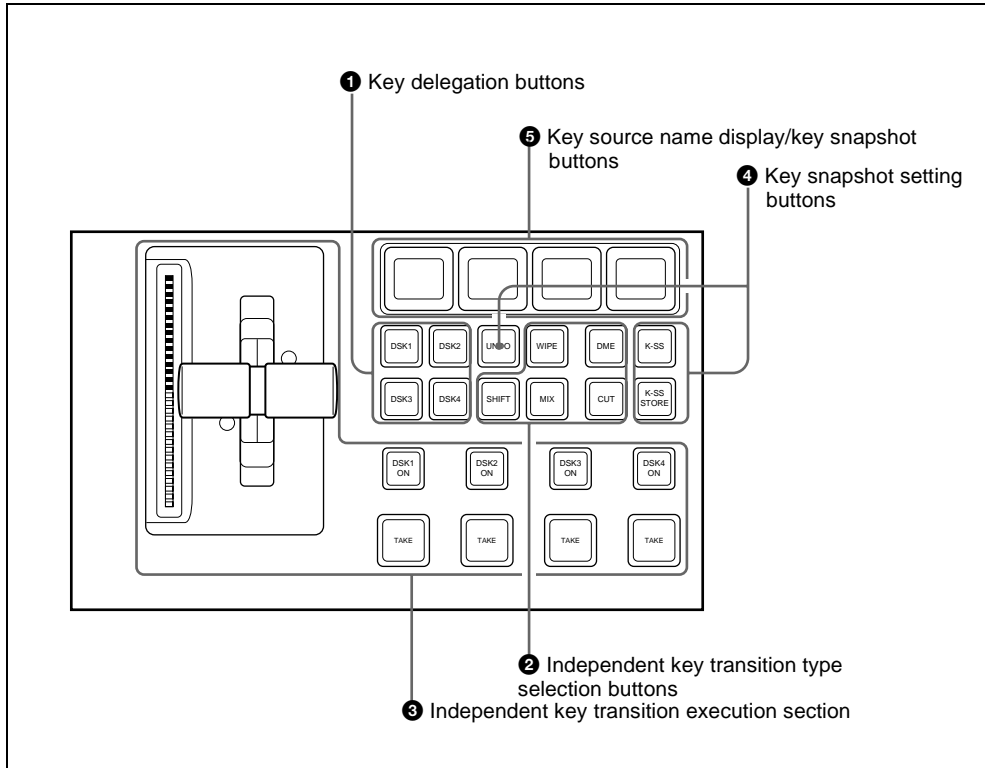
This enables key snapshot mode. In key snapshot mode, it is possible to save and recall key snapshots.

4 Key source name display/key snapshot buttons

These show the signal name of the key fill selected for key 3 and the transition rate on two buttons. In key snapshot mode, these correspond to registers 1 and 2 for key 3; press to save or recall a key snapshot.



Downstream Key Control Block



1 Key delegation buttons

Press one of the [DSK1] to [DSK4] buttons to delegate this control block to the corresponding keyer.

Using the Setup menu, it is possible to delegate this control block to key 1 to key 4 of the M/E bank.

2 Independent key transition type selection buttons

Press one of these buttons, turning it on, to select the downstream key transition type.

MIX: Carry out a dissolve with the key selected with the key delegation buttons.

WIPE: Carry out a wipe with the key selected with the key delegation buttons.

DME: This switches the key selected with the key delegation buttons, using a DME wipe.

CUT: Instantaneously insert or delete the key selected with the key delegation buttons.

SHIFT: When setting is made in the Setup menu to allow a different transition type for inserting or deleting a key, it is possible to set the transition after the next transition while this button is held down.



③ Independent key transition execution section

DSK1 (downstream key 1) ON to DSK4

ON buttons: Press these to instantaneously cut the downstream keys 1, 2, 3, and 4 in or, when the downstream keys are already inserted, cut them out. When the key corresponding to the button appears in the final program output, the button lights red, and otherwise lights amber.

TAKE buttons: These correspond to downstream keys 1, 2, 3, and 4 from left to right; press to execute an auto transition. The transition starts immediately, and the button lights amber. When the transition completes, the button goes off.

Fader lever: Move this to carry out a manual downstream key transition.

Transition indicator: This comprises 30 LEDs, which show the progress of the downstream key transition.

④ Key snapshot setting buttons

K-SS (key snapshot): This enables key snapshot mode.

K-SS STORE (key snapshot store): To save a key snapshot, hold down this button, and press the [key source name display/key snapshot] button for the register you want to save.

UNDO (key snapshot recall undo): This undoes the last key snapshot recall.

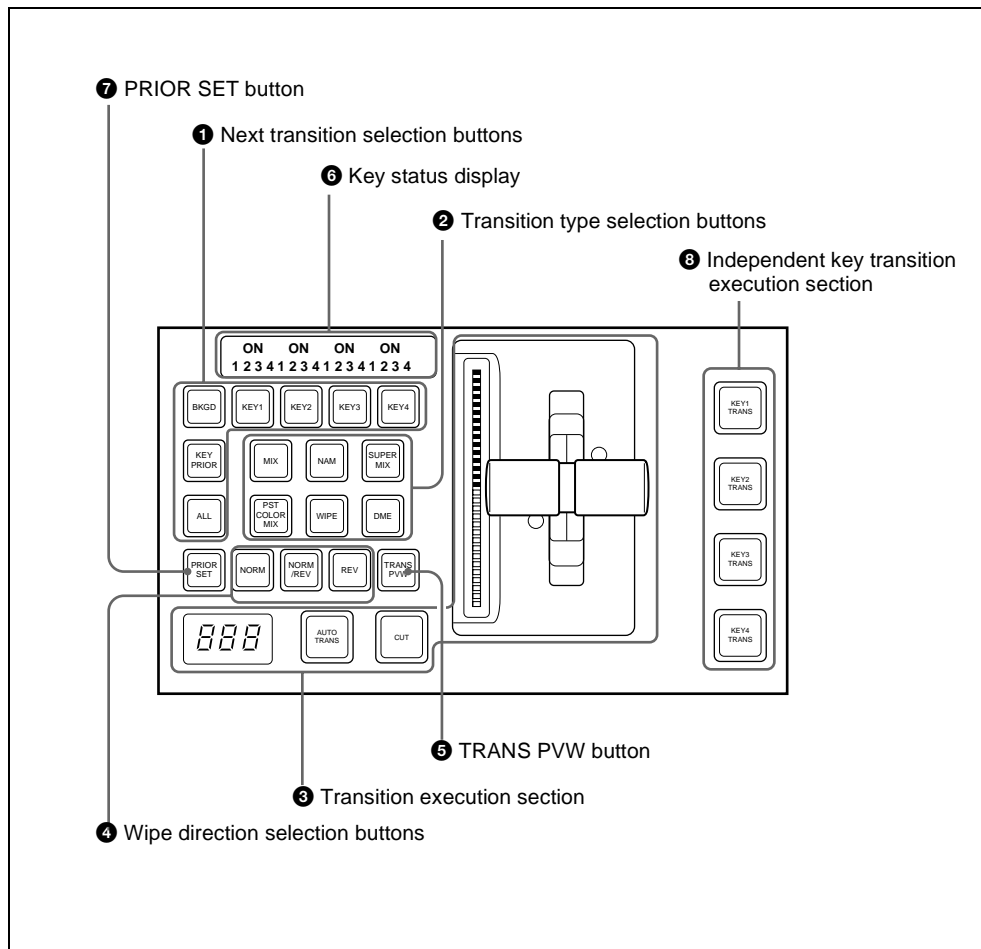
⑤ Key source name display/key snapshot buttons

These display the selected source name for each corresponding keyer. In snapshot mode, they correspond to registers 1 to 4 of the selected keyer, and pressing the button saves or recalls a key snapshot.

Transition Control Block (Compact Type)

The compact version of the transition control block shown below has fewer buttons than the standard type. Independent key transition operations can also be

controlled with the compact transition control block.



1 **Next transition selection buttons**
 Press these buttons, turning them on, to determine what the next transition will apply to.
BKGD: Next transition changes the background.

KEY1 to KEY4 (DSK1 to DSK4 in the PGM/PST bank): Press this button, turning it on, to make the next transition insert or remove the corresponding key (keys 1 to 4). If a key is currently inserted it will be

removed, and if it is not currently inserted, it will be inserted.

In the PGM/PST bank, this inserts or removes downstream keys 1 to 4.

KEY PRIOR (priority): When this button is lit, the setting of the key priority after the next transition is enabled. The key priority after the next transition appears in the key status display.

ALL: Pressing this button turns on a preselected set of the [BKGD], [KEY1] to [KEY4], and [KEY PRIOR] buttons. Make this setting in a Setup menu.

② Transition type selection buttons

Press one of these buttons, turning it on, to determine the type of the next transition. When multi-program mode is selected in the Setup menu (see “Settings for Switcher Configuration (Config Menu)” in Chapter 16 (Volume 2)), two or more of the following buttons may light.

MIX: In a background transition, the new video fades in as the current video fades out. During the transition, the overall signal level is maintained at 100%.

In a key transition, the key fades in (for insertion) or out (for removal).

NAM (non-additive mix): The current and new video signals are compared, and the signal with the higher luminance level is given priority in the output. The current video is maintained at 100% output for the first half of the transition as the new video increases progressively to 100%, then the current video is progressively reduced from 100% to zero in the second half while the new video is maintained at 100%.

SUPER MIX: The current video is maintained at 100% output for the first half of the transition as the new video is mixed while increasing progressively to 100%. The current video is then progressively reduced from 100% to

zero in the second half while the new video is maintained at 100%.

PST (preset) COLOR MIX: In the first transition, the current video is replaced by the color matte in a mix (dissolve), then in the second transition the color matte is replaced by the new video also in a mix (dissolve).

WIPE: The current video is replaced by the new video, using the wipe pattern selected in the Wipe menu.

DME: A wipe type of transition is carried out, using the DME effect selected in the DME Wipe menu.

③ Transition execution section

Transition indicator: This comprises 30 LEDs, which show the progress of the transition.

Fader lever: Move this to carry out a manual transition.

Transition rate display: This shows the “transition rate” (the time from the beginning of a transition to its completion) set for an auto transition, in frames.

You can set the transition rate using the numeric keypad control block, Flexi Pad control block, or menu.

AUTO TRANS (transition) button:

Pressing this button carries out an auto transition of the set transition rate (duration). The transition starts immediately, and the button lights amber. When the transition completes, the button goes off.

CUT button: Pressing this button carries out the transition as a cut (i.e. instantaneously).

④ Wipe direction selection buttons

When you have selected a wipe or DME wipe as the transition type, press one of these buttons, turning it on, to select the wipe direction.

NORM (normal): The wipe proceeds in the direction from black to white as shown on the pattern in the lists of patterns (*see the appendixes “Wipe Pattern List” and “DME Wipe Pattern List” (Volume 2)*), or in the direction of the arrow.

REV (reverse): The wipe proceeds in the opposite direction to that when the [NORM] button is pressed.

NORM/REV (normal/reverse): The wipe direction alternates between normal and reverse every time a transition is executed.

5 TRANS PVW (transition preview) button

When this button is lit, you can check in advance the video changes during the transition, on the preview output from the M/E or PGM/PST bank.

During the preview, you can use the fader lever, [AUTO TRANS] button, and [CUT] button. One of the following functions of this button can be selected in a Setup mode.

- When the transition completes, the system returns to the normal mode.
- The transition preview mode is maintained while this button is pressed.
- Switching is made between the transition preview mode and normal mode every time this button is pressed.

6 Key status display

For each of keys 1 to 4, the corresponding ON indicator lights when the key is inserted. It also shows the priority (1 to 4) of each key.

7 PRIOR (priority) SET button

While this button is held down, you can set the key priority.

The setting mode when this button is pressed depends on whether or not the [KEY PRIOR] button is lit, as follows.

- When the [KEY PRIOR] button is off, the current key priority is set.
- When the [KEY PRIOR] button is lit, the key priority after the next transition is set. Press the [KEY PRIOR] button as required, to switch between these two modes. In either mode, hold down the [PRIOR SET] button, and press the button ([KEY1] to [KEY4]) corresponding to the key you want to bring to the front.

8 Independent key transition execution section

KEY1 TRANS (transition) to KEY4 TRANS (DSK1 TRANS to DSK4 TRANS in the PGM/PST block)

buttons: Press the corresponding one of these buttons to cut key 1 to key 4 in or out automatically at the set transition rate. When the key corresponding to the button appears in the final program output, the button lights red, and otherwise lights amber.

Basic Menu Operations

Menu Organization

Operations on the DVS-9000 switcher system make frequent use of menu operations.

This section describes the menus and their interrelationships.

For details of the VF buttons and HF buttons, see “Interpreting the Menu Screen” (page 216).

Overview

All detailed settings for basic operations such as transitions, keys, DME, or wipes, are made in menus. There are also menus for carrying out general system control, managing setting data, and initial setup.

Accessing menus

You can use any of the following methods to access a menu, and the initially displayed menu page depends on the method used.

- Pressing a top menu selection button in the menu control block.
This displays the page you last accessed in the particular menu. After initially powering on the system, however, the page of VF1 - HF1 of the particular menu is always selected.
- Pressing a top menu selection button in the menu control block twice in rapid succession.
The page of VF1 - HF1 of the particular menu is displayed.
- Pressing a button other than a top menu button twice in rapid succession (*see page 212*).
Depending on the button, this may display a fixed page or the page selected last time you accessed the menu.

Menus accessed from a top menu selection button

Buttons	Menus	Function	See
M/E 1	M/E-1	Transition, keys, and wipe settings for the M/E-1 bank	page 232 (transitions), page 262 (keys), page 304 (wipes)
M/E 2	M/E-2	Transition, keys, and wipe settings for the M/E-2 bank	
M/E 3	M/E-3	Transition, keys, and wipe settings for the M/E-3 bank	
P/P	PGM/PST	Transition, downstream key, and wipe settings for the PGM/PST bank	
FRAME MEM	Frame Memory	Frame memory settings	page 348
COLOR BKGD	Color Bkgd	Color background settings	page 368
AUX/MON	Aux/Mon	Aux bus settings	page 378
COPY SWAP	Copy/Swap	Copy and swap settings	page 372
MISC	Misc	Safe title settings	page 376
DME	DME	DME special effect settings	Chapter 11 (Volume 2)
GLB EFF	Global Effect	Global effect settings	Chapter 11 (Volume 2)
DEV	Device	Settings for external device operation	Chapter 12 (Volume 2)
MCRO	Macro	Macro register settings	Chapter 18 (Volume 2)
KEY FRAME	Key Frame	Keyframe settings	Chapter 13 (Volume 2)
EFF	Effect	Keyframe effect register settings	Chapter 13 (Volume 2)
SNAP SHOT	Snapshot	Snapshot register settings	Chapter 14 (Volume 2)
SHOTBOX	Shotbox	Shotbox register settings	Chapter 15 (Volume 2)
FILE	File	File settings	Chapter 17 (Volume 2)
ENG SETUP	Engineering Setup	Setup functions	Chapter 16 (Volume 2)



Menus accessed by pressing a button twice

For certain buttons other than the top menu selection buttons, pressing twice in rapid succession directly recalls a related menu page. The following table lists these

buttons, together with the menus they recall. (“Xx” represents the HF menu recalled last in the VF menu.)

Menus accessed by pressing a button twice

Button locations	Buttons	Menus	See
Transition control block of M/E-1, M/E-2, or M/E-3 bank	KEY1	M/E-1, 2, 3 Key1>Xx	page 262
	KEY2	M/E-1, 2, 3 Key2>Xx	
	KEY3	M/E-1, 2, 3 Key3>Xx	
	KEY4	M/E-1, 2, 3 Key4>Xx	
Transition control block of PGM/PST bank	DSK1	PGM/PST DSK1>Xx	
	DSK2	PGM/PST DSK2>Xx	
	DSK3	PGM/PST DSK3>Xx	
	DSK4	PGM/PST DSK4>Xx	
Transition control block of M/E-1, M/E-2, M/E-3, or PGM/PST bank	PRIOR SET	M/E-1, 2, 3, PGM/PST Misc>Key Priority	page 229
	KEY PRIOR	M/E-1, 2, 3, PGM/PST Misc>Next Key Priority	page 230
	WIPE	M/E-1, 2, 3, PGM/PST Wipe>Main Pattern	page 304
	DME	M/E-1, 2, 3, PGM/PST DME Wipe>Xx	page 332
	SUPER MIX	M/E-1, 2, 3, PGM/PST Misc>Transition	page 233
	PST COLOR MIX	M/E-1, 2, 3, PGM/PST Misc>Transition	page 234
Independent key transition control block of M/E-1, M/E-2, or M/E-3 bank	KEY1	M/E-1, 2, 3 Key1>Xx	page 262
	KEY2	M/E-1, 2, 3 Key2>Xx	
	KEY3	M/E-1, 2, 3 Key3>Xx	
	KEY4	M/E-1, 2, 3 Key4>Xx	
Independent key transition control block of PGM/PST bank	DSK1	PGM/PST DSK1>Xx	
	DSK2	PGM/PST DSK2>Xx	
	DSK3	PGM/PST DSK3>Xx	
	DSK4	PGM/PST DSK4>Xx	

Menus accessed by pressing a button twice

Button locations	Buttons	Menus	See
Independent key transition control block of M/E-1, M/E-2, M/E-3, or PGM/PST bank ^{a)}	WIPE	<ul style="list-style-type: none"> M/E-1, 2, 3, Key1 to Key4>Transition>Wipe Adjust>Pattern Select PGM/PST DSK1 to DSK4>Transition>Wipe Adjust>Pattern Select 	page 322
	DME	<ul style="list-style-type: none"> M/E-1, 2, 3, Key1 to Key4>Transition>DME Wipe Adjust>1ch Pattern Select PGM/PST DSK1 to DSK4>Transition>DME Wipe Adjust>1ch Pattern Select 	page 339
	K-SS STORE ^{e)}	Snapshot>Key Snapshot>Xx	Chapter 14 (Volume 2)
	SHIFT	M/E-1, 2, 3 Key3 and Key4>Xx ^{d)} PGM/PST DSK3 and DSK4>Xx ^{d)}	page 262
Flexi Pad control block of M/E-1, M/E-2, M/E-3, or PGM/PST bank	WIPE	M/E-1, 2, 3, PGM/PST Wipe>Main Pattern>Xx	page 304
	DME	M/E-1, 2, 3, PGM/PST DME Wipe>Xx	page 332
	SNAPSHOT	Snapshot>Snapshot>Xx	Chapter 14 (Volume 2)
Key control block ^{b)}	KEY1	M/E-1, 2, 3 Key1 and PGM/PST DSK1>Xx	page 262
	KEY2	M/E-1, 2, 3 Key2 and PGM/PST DSK2>Xx	
	KEY3	M/E-1, 2, 3 Key3 and PGM/PST DSK3>Xx	
	KEY4	M/E-1, 2, 3 Key4 and PGM/PST DSK4>Xx	
	LUM	M/E-1, 2, 3 Key1 to Key4>Type PGM/PST DSK1 to DSK4>Type	
	LIN		
	CVK		
	PTN		
CRK	M/E-1, 2, 3 Key1 to Key4>Type>Chroma Adjust PGM/PST DSK1 to DSK4>Type>Chroma Adjust	page 266	
Numeric keypad control block ^{c)}	SNAPSHOT	Snapshot>Snapshot>Xx	Chapter 14 (Volume 2)
	TRANS RATE	PGM/PST Misc>Transition	page 239



Menus accessed by pressing a button twice

Button locations	Buttons	Menus	See
Downstream key control block	DSK1	The menu recalled depends on the keyer assigned in the Setup menu.	page 262
	DSK2		
	DSK3		
	DSK4		
	WIPE	PGM/PST DSK1 to DSK4>Transition>Wipe Adjust>Pattern Select	page 322
	DME	PGM/PST DSK1 to DSK4>Transition>DME Wipe Adjust>1ch Pattern Select	page 339
	K-SS STORE ^{e)}	Snapshot>Key Snapshot>Xx	Chapter 14 (Volume 2)
Buttons in M/E-1, M/E-2, M/E-3, PGM/ PST, or AUX bank to which the signal indicated in "Buttons" column is assigned	FM1 to 8	Frame Memory>Recall>Recall Thumbnail	page 354
	Color Bkgd1	Color Bkgd>Color Bkgd1	page 368
	Color Bkgd2	Color Bkgd>Color Bkgd2	
AUX delegation buttons	FMS1, FMS2	Frame Memory>Edit>Freeze	page 352

- a) The menu recalled depends on which of keyers 1 to 4 the independent key transition control block is delegated to.
- b) The menu recalled depends on which of the M/E delegation buttons and key delegation buttons are selected in the key control block.

- c) The menu recalled depends on which of the M/E-1 to M/E-3 banks and PGM/PST bank the numeric control block is delegated to.
- d) For simple type modules only.
- e) Recalling is possible only when the function is enabled.

Accessing a Menu

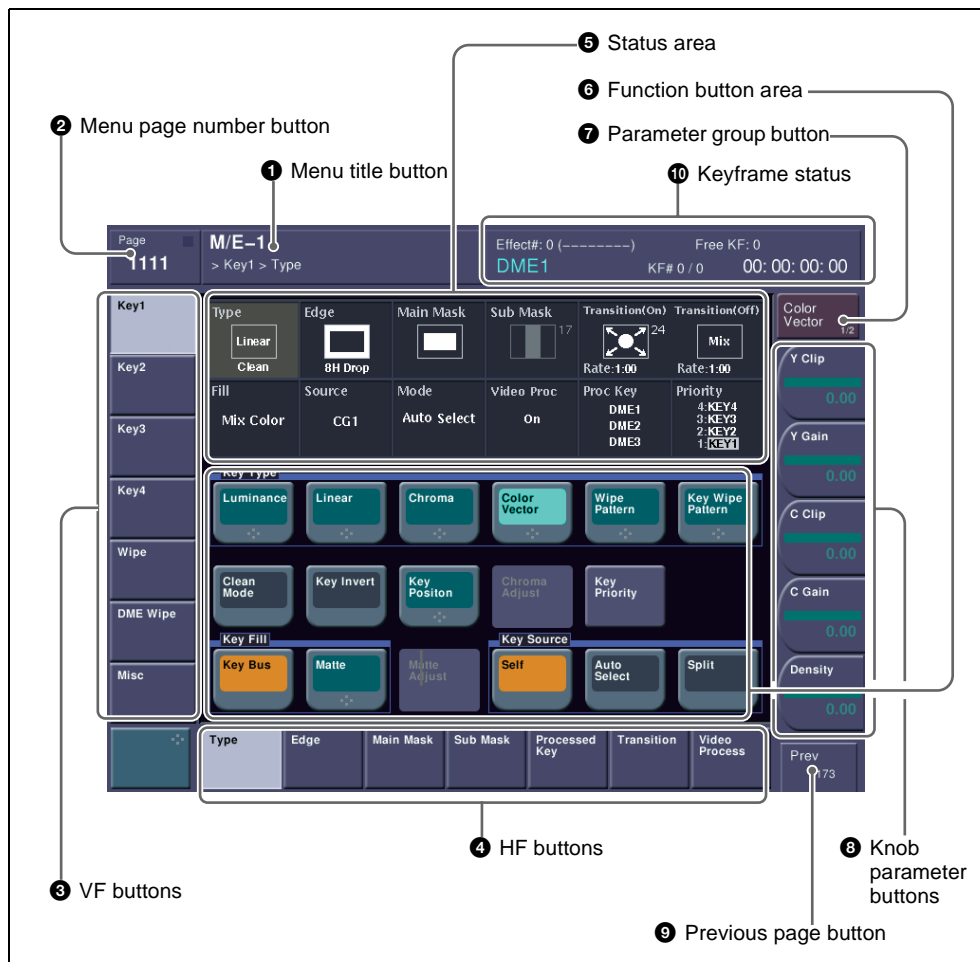
To display, for example, the M/E-1>Key1>Type menu, use any of the following operations.

- Press the top menu selection button [M/E 1], then press the VF1 ‘Key1’ button and the HF1 ‘Type’ button in that order.
- Press the menu page number button in the upper left corner of the menu screen to

display the numeric keypad window, then enter the page number of the M/E-1>Key1>Type menu, which is 1111, and press the [Enter] button.

For details of the menu page numbers, see the appendix “Menu Tree” (Volume 2).

The M/E-1>Key1>Type menu appears in the menu display as follows.



M/E-1>Key1>Type menu

Interpreting the Menu Screen

The menu screen consists of the following principal parts.

When buttons on the screen are lit or represented in a depressed state, this indicates that the corresponding item or function is selected (set on).

1 Menu title button

This shows the title of the menu screen. Pressing this button displays status information about the top menu.

2 Menu page number button

This shows the menu screen page number. Pressing this button brings up the numeric keypad window (*see page 218*). You can enter the page number of another menu, and move directly to that menu.

3 VF buttons

These indicate the larger subdivisions of this menu. Depending on the selected item, the menu screen contents including the HF button indications change.

4 HF buttons

These indicate the items within the menu. Depending on the selected item, the menu indications change.

5 Status area

This shows the status of the settings items controlled by the selected menu.

6 Function button area

This shows the functions which can be operated in the currently selected menu by means of buttons.

Each function button corresponds to a function which can be set in the currently

selected menu. Press it to enable the function, to display a parameter group and adjust the parameters with the knobs, or to execute the function.

These buttons are in groups by function. In the screen example shown on the previous page, the [Key Bus] and [Matte] function buttons constitute the <Key Fill> group.

7 Parameter group button

This displays parameter group names for which the knobs can make adjustments, the current parameter setting page number, and the total number of the parameter setting pages. (Example: Color Vector 1/2)

When there are more than five parameters within the same parameter group, press this button to display the sixth and subsequent parameters, which can then be controlled by the knobs.

8 Knob parameter buttons

These show the parameters currently controlled by the knobs and their values. Pressing one of these buttons displays the numeric keypad window (*see page 218*), and you can then enter a new value for the corresponding parameter with the numeric keypad.

9 Previous page button

This shows the page number of the previously displayed menu screen. Press it to go back to that page. When the indication [Parent] appears, this displays the parent directory.

10 Keyframe status

This shows the keyframe status of the reference region. Pressing this button switches the menu screen as follows.

When a menu other than the Key Frame menu is currently shown: The menu screen switches to the Key Frame menu.

When the Key Frame menu is currently shown: The menu screen switches to the menu that was on the screen immediately before the Key Frame menu.

Lit purple: Execution button. Pressing the button immediately executes the function. (Example: [Auto Start] button in the Chroma Adjust menu)

Menu Operations

Selecting an item

Use the following procedure.

- 1 Press the VF button (1 to 7) for the desired group of items.

The HF button (1 to 7) indications change to show the items within the selected group.

- 2 Press the HF button for the desired item.

The indications in the status area and function button area change, and you can now make various changes to the selected item.

Selecting a function

Press the appropriate function button within the function button area.

Shape and color of the button

Pressing the button turns it on, and it lights, showing the state.



Lit pale blue: The function is enabled, and the parameters can currently be adjusted with the knobs.

Lit orange: The function is enabled.



Pressing a button of this type displays a further menu, allowing more detailed settings. (Example: [Chroma Adjust] button in the Type menu)

Setting parameters



This marking on a function button indicates that there are parameters which can be adjusted with the knobs.

Pressing this function button assigns parameters to the knobs.

You can set the parameter values by any of the following methods.

- Turn the knob (1 to 5) corresponding to the parameter, to adjust the value.
- Press the knob parameter buttons (1 to 5) corresponding to the parameter. This displays the numeric keypad window allowing you to enter the desired value.

In the description of specific setting procedures, the knob adjustment is described, as follows.

Example: When wipe pattern key is selected

Knob	Parameter	Adjustment	Setting values
1	Size	Pattern size	0.00 to 100.00
2	Soft	Edge softness	0.00 to 100.00
3	Density	Key density	0.00 to 100.00

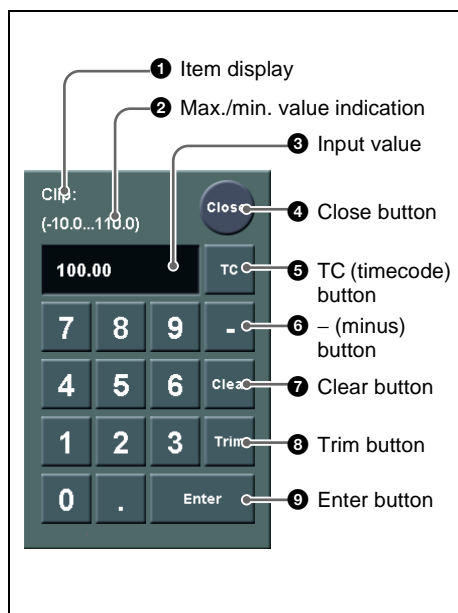
When the [MENU] button in the device control block is lit, you can use the trackball and Z-ring to control the parameters.

- Move the trackball on the x-axis to control the parameter for knob 1 or on the y-axis to control the parameter for knob 2. Moving up or to the right increases the parameter value, and moving down or to the left decreases the parameter value.
- Use the Z-ring to adjust the parameter for knob 3. Turning clockwise increases the parameter value, and turning counterclockwise decreases the parameter value.

Going back to the previous menu

To return to the last displayed menu, press the previous page button.

Numeric keypad window



1 Item display

This is the name of the parameter being set in the numeric keypad window.

2 Max./min. (maximum/minimum) value indication

This shows the maximum and minimum settings of the parameter.

3 Input value

This is the value being input into the numeric keypad window.

4 Close button

This closes the numeric keypad window.

5 TC (timecode) button

When the numeric keypad window is opened for a setting requiring a timecode value to be entered, this button appears in a depressed state.

You can enter a timecode value in the range that depends on the signal format (*page 146*) as follows:

00:00:00:00 to 23:59:59:nn,
where nn = (number of frames per second) – 1.

6 – (minus) button

This toggles the sign of the entered value. When it is pressed, the value is negative.

7 Clear button

This clears the input. It does not change the parameter setting.

8 Trim button

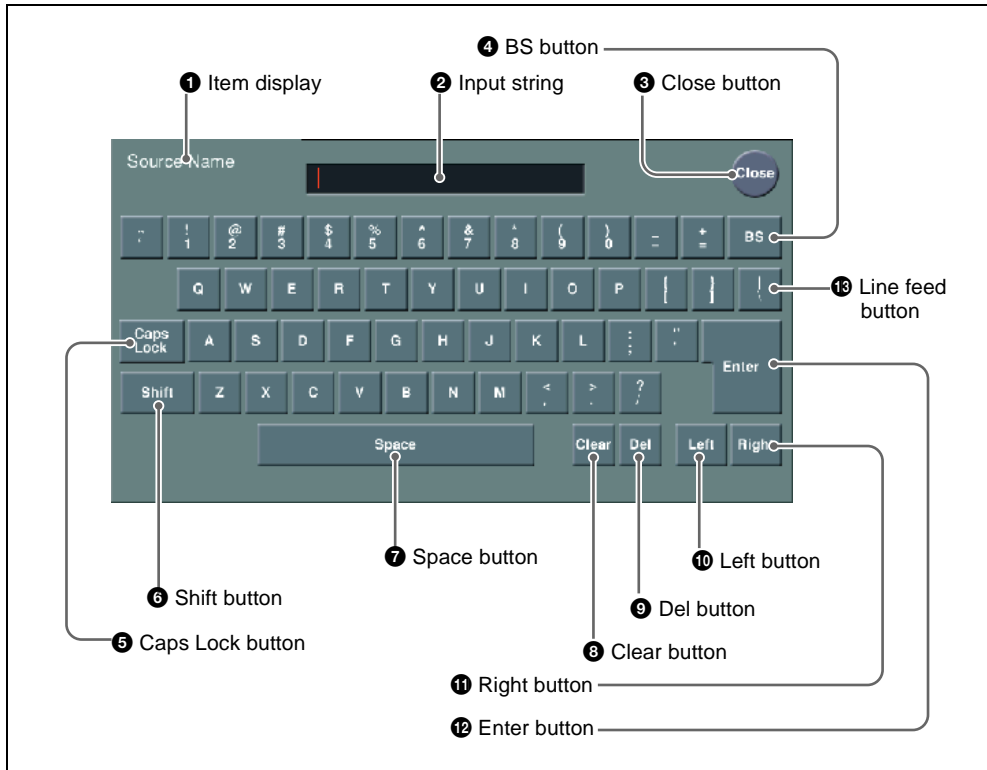
After entering the difference from the current value, press this button to confirm the numeric input.

9 Enter button

This confirms the entered value.



Keyboard window



1 Item display

This is the name of the parameter being set in the keyboard window.

2 Input string

This is the character string being input in the keyboard window.

3 Close button

This closes the keyboard window.

4 BS button

This clears the character immediately before the cursor in the input string.

5 Caps Lock button

This enables input of capital letters only.

Note

You can enter items to be displayed on the control panel LCD using lowercase letters, but these will be converted to capitals for display.

MS-DOS does not distinguish case in filenames, and therefore you are recommended to enter filenames in capital letters.

6 Shift button

This selects the characters on the shift side of the keys. The shift is released when you enter a character.

7 Space button

This enters a space character.

8 Clear button

This clears all of the characters in the input string.

9 Del button

This clears the character immediately after the cursor in the input string.

10 Left button

This moves the cursor one character to the left in the input string.

11 Right button

This moves the cursor one character to the right in the input string.

12 Enter button

This sets the input string as a parameter value, and closes the keyboard window if the value has been entered correctly. If the value has not been entered correctly, the display color changes.

13 Line feed button

After pressing the Shift button, press this button to feed a line. The input string shows “|”.

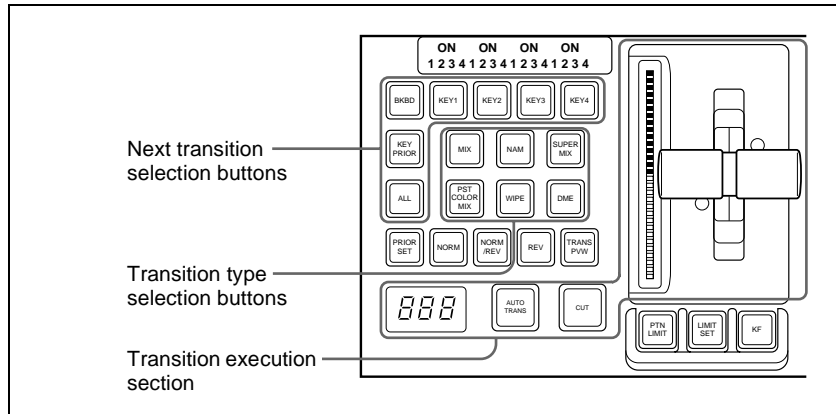


Chapter 3 Transitions

Basic Operating Procedure	224
Key Priority Setting	227
Setting the Key Priority in the Transition Control Block.....	227
Setting the Key Priority by a Menu Operation.....	229
Display of the Key Output Status and Key Priority.....	230
Selecting the Transition Type by a Menu Operation	232
Super Mix Settings	233
Color Matte Settings	234
Executing a Transition	235
Transition Indicator Function.....	235
Setting the Transition Rate.....	236
Pattern Limit.....	239
Executing an Auto Transition.....	243
Executing a Transition With the Fader Lever (Manual Transition)	243
Combinations of Auto and Manual Transitions.....	244
Non-Sync State.....	244
Fader Lever Operation in Bus Fixed Mode.....	245
Transition Preview	247
Independent Key Transitions	248
Basic Independent Key Transition Operations.....	248
Setting the Independent Key Transition Type by a Menu Operation..	249
Setting the Independent Key Transition Rate.....	250
Fade to Black	253
Fade to Black Operation.....	253
Setting the Fade to Black Transition Rate.....	253
Simple Transition	255
Basic Operations for Simple Transitions.....	255
Display of the Key Output Status and Key Priority.....	257
Split Fader.....	257
Independent Key Transitions With a Simple Transition Module..	258

Basic Operating Procedure

The positions of the principal buttons used for basic transition operation are as follows.



Transition control block (for standard transitions)

For basic transition operations, use the following procedure.

- 1 In the cross-point control block, select the background video with the background A row of cross-point buttons.
- 2 Select the way in which the transition will affect the image, using the next transition selection buttons in the transition control block.

For an overview, see “Selecting the Next Transition” (page 32).

To change the background: Press the [BKGD] button, turning it on.

To insert or delete a key: Press one of the [KEY1] to [KEY4] buttons (or [DSK1] to [DSK4] buttons in the PGM/PST bank), turning it on.

To enable the key priority setting, which determines the key overlay order after the transition: Press the [KEY PRIOR] button, turning it on.

You can press more than one button at the same time.

To change the keys and background presets in Setup menus simultaneously: Press the [ALL] button.

To allocate a particular next transition button to the [ALL] button function, see “Operation Settings (Operation Menu)” in Chapter 16 (Volume 2).

- 3** For the transition to change the key priority, set the priority for after the transition.

*For details of the key priority, see “Selecting the key priority” (page 34).
For details of the key priority setting operation, see “Key Priority Setting” (page 227).*

- 4** Select the new video used for the transition.

- In the background B row of cross-point buttons, select the new background video.
- When inserting a key, select the key signal, and make any required settings.

For details of key settings, see Chapter 4 “Keys” (page 261).

To carry out a cut transition, skip to step **7**; otherwise continue to step **5**.

- 5** Select one of the transition type selection buttons in the transition control block.

To carry out a dissolve to the new video: Press one of the [MIX], [NAM], [SUPER MIX], and [PST COLOR MIX] buttons, turning it on.

To carry out a wipe: Press the [WIPE] or [DME] button, turning it on.

You can also use the Misc>Transition menu to select a desired transition type for the M/E or PGM/PST bank. (*See “Selecting the Transition Type by a Menu Operation” (page 232).*)

For an overview of the transition types, see “Transition Types” (page 39).

- 6** Make the required settings, according to the selected transition type.

For details of the settings, see the relevant section.

Super mix: “*Super Mix Settings*” (page 233)

Preset color mix: “*Color Matte Settings*” (page 234)

Wipe: “*Basic Procedure for Wipe Settings*” (page 304)

DME Wipe: “*Basic Procedure for DME Wipe Settings*” (page 332)

Using the transition preview function (page 247), you can check the transition on the preview monitor.

- 7** Carry out the transition in the transition execution section.

For a gradual transition such as a mix (dissolve) or wipe: Press the [AUTO TRANS] button, or operate the fader lever.

To execute a transition by pressing the [AUTO TRANS] button, first set the transition rate (specified as the duration of the transition).

(*See “Setting the Transition Rate” (page 236).*)

When you have selected a wipe or DME wipe as the transition type, you can also set the transition range. (*See “Pattern Limit” (page 239).*)
For an instantaneous transition: Press the [CUT] button.
For details, see “Executing a Transition” (page 235).

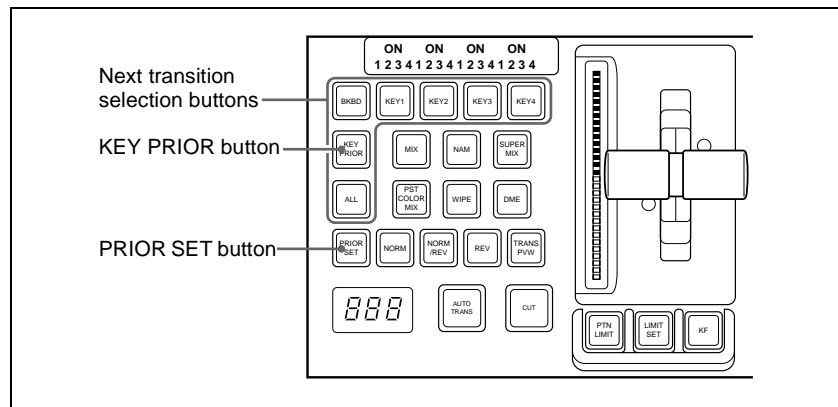


Key Priority Setting

You can select the key priority, that is, the order in which the keys are laid over each other, in the current video and after the transition. There are two ways of setting the priority: either using the [PRIOR SET] button in the transition control block, or using the Misc menu to access the Key Priority menu for the M/E or PGM/PST bank.

Setting the Key Priority in the Transition Control Block

The positions of the buttons used for the operation are as follows.



Transition control block (standard type)

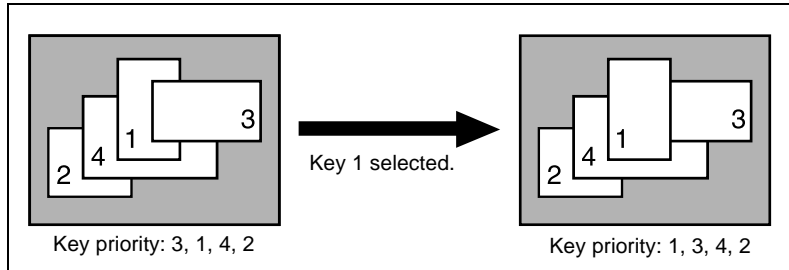
Changing the currently inserted key priority

Use the following procedure.

- 1 If the next transition selection button [KEY PRIOR] is on, press another next transition selection button to turn the [KEY PRIOR] button off.
(When the [KEY PRIOR] button is on, the transition control block switches to the mode for changing the key priority for after the transition.)

- 2 Holding down the [PRIOR SET] button, press the one of the next transition selection buttons [KEY1] to [KEY4] ([DSK1] to [DSK4] buttons in the PGM/PST bank) for the key to appear on top.

The selected key now appears on top, on the program monitor.
The priority of keys other than the selected one does not change.



To change the priority of more than one key, repeat the above operation as required.

Changing the key priority for after the transition

When executing a transition, turning on the next transition selection button [KEY PRIOR] causes the keys to be rearranged based on the set priority. To set the key priority for after the transition, use the following procedure.

- 1 In the transition control block, hold down the [PRIOR SET] button and press the [KEY PRIOR] button to turn it on. Do not release the [PRIOR SET] button before advancing to step 2.

The [KEY PRIOR] button lights green, and it becomes possible to change the key priority setting for after the transition.

- 2 Hold down the [PRIOR SET] button, and press the one of the next transition selection buttons [KEY1] to [KEY4] ([DSK1] to [DSK4] buttons in the PGM/PST bank) for the key you want to bring to the front after the transition.

To set the priority to be the same as before the transition, press the [BKGD] button.

Note

The [BKGD] button is only effective when in the mode for changing the key priority for after the transition.

When the next transition selection button [KEY PRIOR] is on, the selected key appears on top on the preview monitor. The priority of keys other than the selected one does not change.

3 To change the priority of more than one key, repeat the above operation as required.

4 Execute the transition.

The keys are rearranged based on the above set priority.

Setting the Key Priority by a Menu Operation

Changing the priority of the currently inserted keys

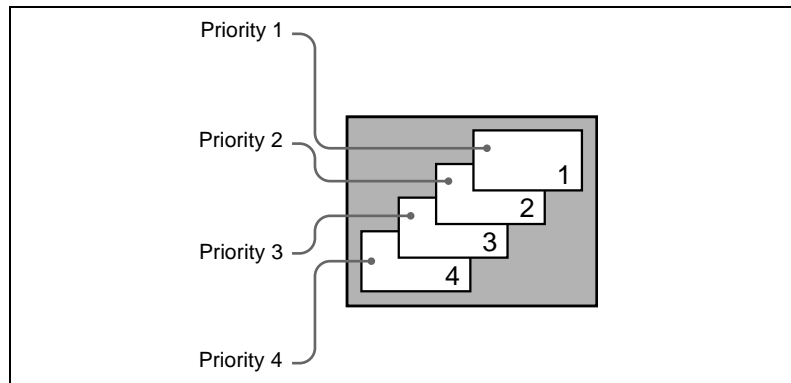
Use the following procedure.

1 In the M/E or PGM/PST menu, select first VF7 'Misc,' then HF3 'Key Priority.'

The Key Priority menu appears.

2 For each of [Priority1], [Priority2], [Priority3], and [Priority4], select a key, to determine the key priority sequence.

The keys are inserted in the key priority sequence with priority 1 at the front.



Note

It is not possible to select the same key for two or more priority numbers.

The keys appear in the set order on the program monitor.

Changing the key priority for after the transition

Use the following procedure.

- 1** In the M/E or PGM/PST menu, select first VF7 'Misc,' then HF4 'Next Key Priority.'

The Next Key Priority menu appears.

- 2** For each of [Priority1], [Priority2], [Priority3], and [Priority4], select a key, to determine the key priority sequence.

For details of the key priority sequence, see the figure shown for step 2 in the previous item (see page 229).

The keys appear in the set order on the preview monitor.

- 3** Execute the transition.

The keys are rearranged in the above set order on the program monitor.

Display of the Key Output Status and Key Priority

You can check whether keys are currently output, and the key priority setting, using the key status display in the transition control block of the M/E or PGM/PST bank.

The display is above the next transition selection buttons [KEY1] to [KEY4] ([DSK1] to [DSK4] buttons in the PGM/PST bank).

Display of the key output status

When a key is included in the output from the M/E or PGM/PST bank, the corresponding ON indicator lights.

Key priority display

The key priority is indicated by numerals 1 to 4 lighting.

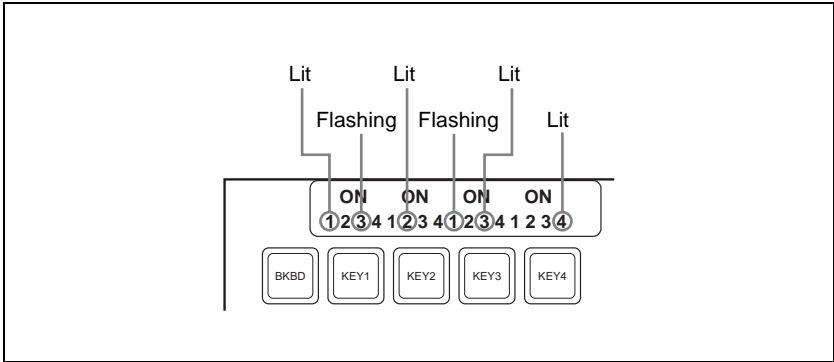
The topmost key as seen on the program monitor is priority 1, and the keys underneath are numbered 2, 3, 4 away from the viewer (see page 229).

To display the key priority for after the transition, press the [KEY PRIOR] button in the transition control block, turning it on. For keys for which the priority after the transition is different from the current priority, the

corresponding numerals 1 to 4 flash. For a key with the same priority, the indication remains on.

Example key status display given when the [KEY PRIOR] button is pressed:

- Current key priority: 1, 2, 3, 4
- Key priority after the transition: 3, 2, 1, 4
- Indicators: 1, 3 (flashing), 2, 1 (flashing), 3, 4



Example key status display (showing the key priority after the transition)

Selecting the Transition Type by a Menu Operation

You can also select the required transition type by a menu operation. Use the following procedure.

- 1** In the M/E or PGM/PST menu, select first VF7 ‘Misc,’ then HF1 ‘Transition.’

The Transition menu appears.

- 2** Select the required transition type in the <Transition Type> group.

The parameter settings can now be adjusted with the knobs according to the selected transition type.

For details, see the following.

- “*Super Mix Settings*” (page 233)
- “*Color Matte Settings*” (page 234)
- “*Setting the Transition Rate*” (page 236)

Note

When multi-program mode is selected in the Setup menu (see “*Settings for Switcher Configuration (Config Menu)*” in Chapter 16 (Volume 2)), there may be cases in which two or more transition types have been selected.



Super Mix Settings

To make the super mix settings, use the following procedure.

For an overview of the super mix, see page 40.

- 1** In the M/E or PGM/PST menu, select first VF7 'Misc,' then HF1 'Transition.'

The Transition menu appears.

- 2** Select [Super Mix] in the <Transition Type> group.

- 3** Turn the knobs to adjust the output levels.

Knob	Parameter	Adjustment	Setting values
2	A Gain	Background A output level	0.00 to 100.00% a)
3	B Gain	Background B output level	0.00 to 100.00% a)

a) Default: 100.00%

Color Matte Settings

To set the color matte of a preset color mix, use the following procedure.

For an overview of the preset color mix, see page 40.

- 1** In the M/E or PGM/PST menu, select first VF7 'Misc,' then HF1 'Transition.'

The Transition menu appears.

- 2** Select [Preset Color Mix] in the <Transition Type> group.

- 3** Turn the knobs to adjust the color matte parameters.

Knob	Parameter	Adjustment	Setting values
2	Luminance	Luminance	0.00 to 100.00%
3	Saturation	Saturation	0.00 to 100.00%
4	Hue	Hue	0.00 to 359.99%



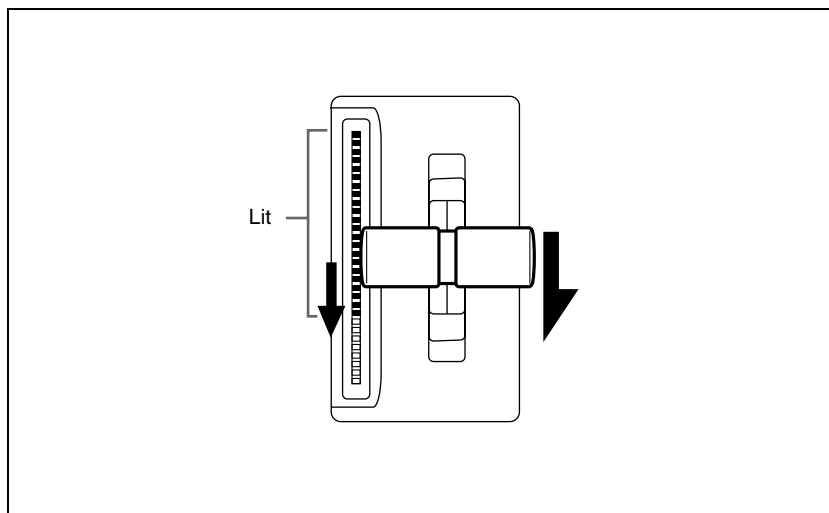
Executing a Transition

There are two ways of executing a transition: as an auto transition by a button operation, and as a manual transition using the fader lever. You can also use a combination of these two modes.

For an overview of the auto transitions and manual transitions, see “Executing a Transition” (page 42).

Transition Indicator Function

In each of the M/E banks and PGM/PST bank, to the left of the fader lever is a transition indicator composed of 30 LEDs. This indicator shows the state of the transition, whether auto or manual, by which LEDs are lit.



Transition indicator

For example, in the illustration above, it can be seen that the transition is more than half completed. When the transition is completed, all of the LEDs go off.

Setting the Transition Rate

There are two ways of setting the transition rate: using the Flexi Pad control block or numeric keypad control block to enter a numeric value, or using the Misc menu to access the Transition menu for the M/E or PGM/PST bank.

Frame input mode and timecode input mode

For numeric input of the transition rate value, there are two modes: frame input mode and timecode input mode. You select one of these modes using either the Flexi Pad control block (*page 237*) or the numeric keypad control block (*page 238*).

Frame input mode: The entered value is a number of frames.

Example: Entering 123 constitutes an entry of 123 frames

Timecode input mode: The entered value is a timecode value.

Example: Entering 123 constitutes an entry of 1 second 23 frames.

Note

Whereas you can enter a value of up to 999 in frame input mode, a value not smaller than 10 seconds cannot be entered in timecode input mode.

Frame display mode and timecode display mode

For the transition rate display in the transition control block, there are two modes: frame display mode and timecode display mode. You can select one of these modes in setup. (*See “Operation Settings” in Chapter 16 (Volume 2).*)

Note

The setting is common to all banks of the switcher.

Frame display mode: Values are shown as from 0 to 999 frames. In this display mode, a value entered in timecode input mode is converted for display as a number of frames.

Timecode display mode: Values are shown as timecode values, consisting of seconds and frames. In this display mode, a value entered in frame input mode is converted for display as a timecode value. If the value consists of four or more digits, the last digit is not shown.

Example: A value of 9 seconds 23 frames appears as “9.23” and a value of 10 seconds 1 frame appears as “10.0.”

Setting the transition rate in the Flexi Pad control block

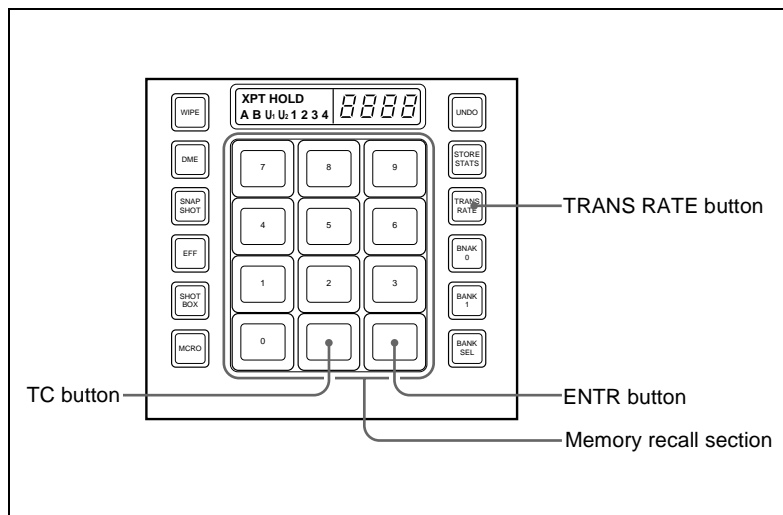
Note

In the PGM/PST bank or when using a simple-type transition control block, you cannot use the Flexi Pad control block to set the transition rate.

Use the following procedure.

- 1 In the M/E bank Flexi Pad control block, press the [TRANS RATE] button.

The memory recall section display is now ready to accept the entered transition rate.



Flexi Pad control block (standard type)

- 2 Enter the desired transition rate with the numeric keypad.

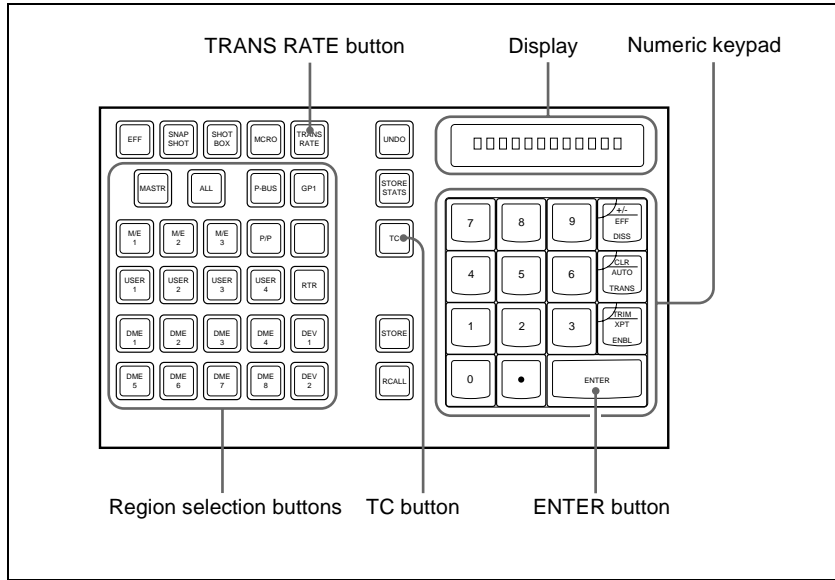
If required, press the [TC] button to toggle the input mode (frame input or timecode input).

- Enter a value of up to three digits.
- To cancel the entry, press any of the six buttons in the leftmost column ([WIPE], [DME], ...) or the [TRANS RATE] button.

- 3 Press the [ENTR] button.

This confirms the entry, and the new setting appears in the transition control block display.

Setting the transition rate in the numeric keypad control block



Numeric keypad control block

Use the following procedure.

- 1** In the numeric keypad control block, press the [TRANS RATE] button.
- 2** Press the region selection button for the M/E or PGM/PST bank for which you want to set the transition rate, turning it on.

The numeric keypad control block display now shows the selected region name and the current transition rate setting for the region.
- 3** With the numeric keypad, enter the transition rate.
If required, press the [TC] button to toggle the input mode (frame input or timecode input).
 - Enter a value of up to three digits.
 - To clear the entry, press the [CLR] button.
- 4** Press the [ENTER] button.

This confirms the entry, and the selected region name and the set transition rate appear in the numeric keypad control block display. The transition control block display of the same bank (M/E or PGM/PST) also shows the setting.



To enter a difference from the current value

After pressing the [+/-] button, enter the difference and press the [TRIM] button.

To change the sign (+ or -), press the [+/-] button.

Setting the transition rate by a menu operation

Use the following procedure.

1 In the M/E or PGM/PST menu, select first VF7 'Misc,' then HF1 'Transition.'

The Transition menu appears.

2 Select any transition type in the <Transition Type> group.

3 Turn the knob to set the transition rate.

Knob	Parameter	Adjustment	Setting values
1	Transition Rate	Transition Rate	0 to 999 (frame count)

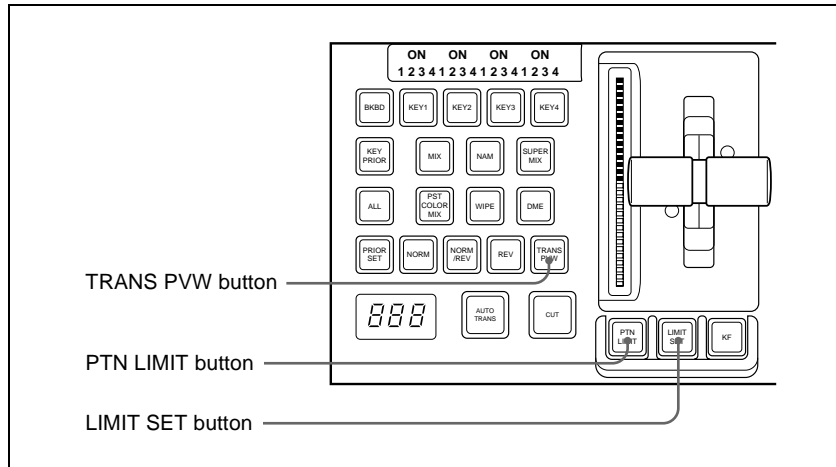
Pattern Limit

There are two ways of setting a pattern limit: either by operating the fader lever to save the fader position, or by using the Wipe menu or DME Wipe menu to access the Edge/Direction menu for the M/E or PGM/PST bank.

For an overview of the pattern limits, see page 44.

Notes

- A pattern limit only applies when a wipe or DME wipe is selected as the transition type.
- A pattern limit cannot be applied to an independent key transition (*see page 248*).



Transition control block (standard type)

Setting the pattern limit with the fader lever

Use the following procedure.

- 1 Move the fader lever to the position corresponding to a particular pattern size.
 - First make sure that the [PTN LIMIT] button is off.
 - To check the pattern size on the preview monitor, first press the [TRANS PVW] button, to select the transition preview mode (*see page 247*).
- 2 Press the [LIMIT SET] button.

This sets the current fader lever position as the pattern limit.

Setting the pattern limit by a menu operation

Use the following procedure.

- 1 When a wipe is selected as the transition type, in the M/E or PGM/PST menu, select first VF5 'Wipe,' then HF4 'Edge/Direction.'
When a DME wipe is selected as the transition type, in the M/E or PGM/PST menu, select first VF6 'DME Wipe,' then HF4 'Edge/Direction.'

The Edge/Direction menu appears.

- 2** Press the [Pattern Limit] button, turning it on.
- 3** Turn the knobs to adjust the following parameters.

Knob	Parameter	Adjustment	Setting values
1	Pattern Limit	Pattern limit	0.00 ^{a)} to 100.00% ^{b)}

a) 0.00%: Executing the transition does not change the video output at all.

b) 100.00%: The transition is the same as when no pattern limit is set, but the cross-point button selections of the background A and B buses do not interchange when the transition completes.

Executing a pattern limit transition

Use the following procedure.

- 1** Press the [PTN LIMIT] button, turning it on.

The button you pressed lights amber.

- 2** Carry out the transition.

The transition progresses as far as the set pattern limit. Even if the transition completes, the cross-point button assignments of the background A and B buses do not interchange.

- 3** Carry out the transition once again.

The status before the previous transition is restored.

To cancel the pattern limit

To cancel the pattern limit after completion of step **3** of the above procedure, press the [PTN LIMIT] button, turning it off.

If after carrying out step **2** above, the pattern limit has been reached, carry out the following procedure.

- 1** Press the [PTN LIMIT] button.

The button you pressed lights green.

- 2** Carry out the transition.

The [PTN LIMIT] button goes off, and the pattern limit state is released. Depending on the way in which the transition was executed, the action will be as follows.

- When you press the [CUT] button, the pattern limit is immediately released, and the image switches instantaneously.

- When you press the [AUTO TRANS] button, until the state of the next transition, the transition is carried out over the duration given by the transition rate.
- When you move the fader lever, the transition is carried out from the pattern limit state to the state before the pattern limit transition was carried out.
However, moving the fader lever even a little synchronizes the fader lever position with the transition state, and you can move the fader lever either in the forward direction or in the reverse direction.

Depending on the Setup settings, the transition may be executed at the instant you press the [PTN LIMIT] button, and the button goes off. In this case, execution continues for the time specified by the dedicated transition rate in the menu setting, as far as the state of the next transition.

For details of the setting, see “Settings Relating to Keys, Wipes and Frame Memory (Key/Wipe/FM Menu)” in Chapter 16 (Volume 2).

To set the transition rate when the pattern limit is released

Use the following procedure.

- 1** In the <Pattern Limit Release> group of the Edge/Direction menu, select one of the following.

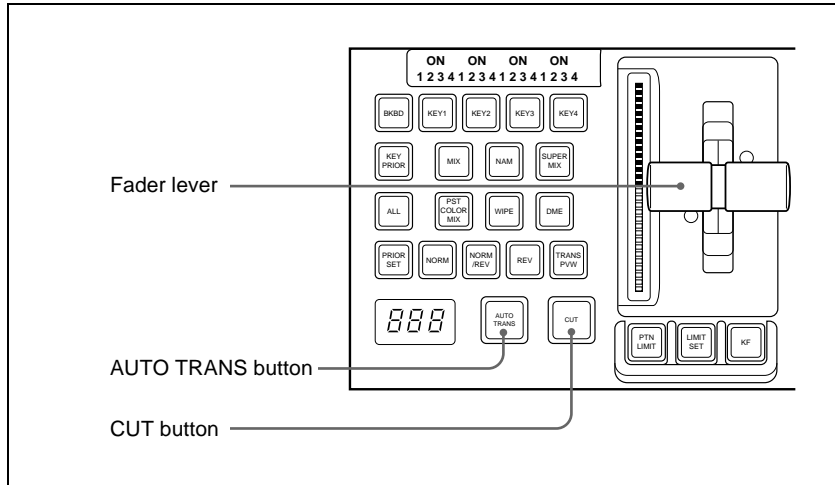
Auto Trans Rate: Use the transition rate set in the transition rate control block

Independ Trans Rate: Independent transition rate

- 2** If you selected “Independ Trans Rate” in step **1**, adjust the following parameter.

Knob	Parameter	Adjustment	Setting values
1	Transition Rate	Independent transition rate	0 to 999 (frames)

Executing an Auto Transition



Transition control block (standard type)

To execute a transition on the M/E or PGM/PST bank by a button operation, use the following procedure in the transition control block.

For an overview of the auto transition, see page 42.

To carry out an instantaneous cut transition: Press the [CUT] button.

To carry out a gradual transition: Press the [AUTO TRANS] button.

This executes the transition at the preset transition rate (*see page 236*).

While the transition is executing, the [AUTO TRANS] button lights amber. When it completes the button goes off.

To complete a partially executed transition instantaneously: Press the [CUT] button.

The [AUTO TRANS] button goes off.

Executing a Transition With the Fader Lever (Manual Transition)

To execute a manual transition with the transition control block fader lever, use the following procedure.

For an overview of the manual transition, see page 43.

To carry out the transition completely: Move the lever over the full range of its travel.

To pause a partly executed transition: Stop moving the fader lever.

To resume a paused transition: Resume moving the fader lever.

Combinations of Auto and Manual Transitions

Using the [AUTO TRANS] button, the [CUT] button, and the fader lever, use the following procedures.

Moving the fader lever during an auto transition

During an auto transition started by pressing the [AUTO TRANS] button, operating the fader lever immediately enables the fader lever, and the [AUTO TRANS] button goes off. Thereafter, the fader lever controls the progress of the transition.

Executing an auto transition after partly moving the fader lever

- Press the [CUT] button to instantaneously complete the transition.
- Press the [AUTO TRANS] button to complete the rest of the transition at the preset transition rate.

If the transition rate is set to 100 frames, and the fader lever has moved through $\frac{1}{4}$ of the transition, then the remaining $\frac{3}{4}$ of the transition is carried out in 100 frames.

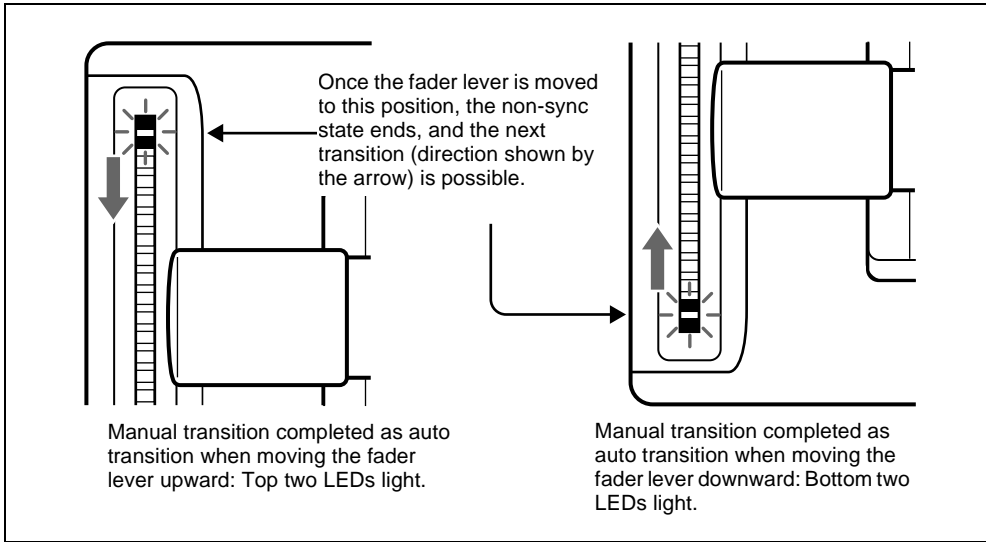
Non-Sync State

If the fader lever is in an intermediate position when a transition is completed as an auto transition, then the lever position no longer agrees with the transition state. This is termed a non-sync state.

In a non-sync state, two lit LEDs indicate the position from which a normal transition can be carried out. This is either at one end position or both end positions of the fader lever travel.

Moving the fader lever toward the position of the lit LEDs does not carry out a transition, but when the fader lever reaches the end position the non-sync state is released, and it is now possible to carry out the next transition.





- If the fader lever is moved in the direction away from the lit LEDs, this carries out the next transition, over the remaining part of the fader lever travel.
- Even in a non-sync state, you can carry out an auto transition by pressing the [AUTO TRANS] button. During the auto transition, the indicators show the transition progress in the usual way, but when the transition completes, they once again indicate the non-sync state.

Fader Lever Operation in Bus Fixed Mode

In the bus fixed mode there is a fixed relationship between the position of the fader lever and the signal output on each bus. Depending on the direction of the transition, the fader lever must therefore always be moved in a particular direction, as shown in the following table. This does not affect an auto transition, which is executed regardless of the fader lever direction.

For an overview of the bus fixed mode, see “Flip-flop mode and bus fixed mode” (page 43).

Fader lever operating direction in bus fixed mode

Next transition	Transition direction	Fader lever movement
Background	A → B	Downward
	B → A	Upward

Next transition	Transition direction	Fader lever movement
Keys 1, 2, 3, and 4	On → Off (deletion)	Downward
	Off → On (insertion)	Upward

- When a transition applies to a combination of more than one of the background and keys 1, 2, 3, and 4, then the transition for all of these must be in the same direction complying with the above table.
- If as a result of an auto transition, for example, the fader lever position does not agree with the signal output, this is a non-sync state (*see page 244*) and LEDs light at both end positions of the fader lever travel. Moving the fader lever does not carry out a transition, but when the fader lever reaches the end position the non-sync state is released, and it is now possible to carry out the next transition. If the fader lever is moved in the direction away from the lit LEDs, this carries out the next transition, over the remaining part of the fader lever travel.

Wipe direction in bus fixed mode

The direction of a wipe is also in a fixed relationship to the fader lever movement direction.

Transition type	Wipe direction	Fader lever movement
Wipe	Normal	Upward
	Reverse	Downward



Transition Preview

Carrying out a transition preview

To carry out a transition preview, use the following procedure.

For an overview of the transition preview, see page 44.

- 1** In the M/E or PGM/PST bank transition control block, press the [TRANS PVW] button.

The [TRANS PVW] button lights green, and the switcher is now in the transition preview mode. At this point, the preview output is the same as the program output before the [TRANS PVW] button was pressed.

- 2** Operate the fader lever, or press the [AUTO TRANS] button or [CUT] button.

On the preview monitor, you can check the effect of the transition.

To terminate a transition preview

There are three modes for a transition preview. To terminate a transition preview, carry out the operation which depends on the mode, and press the [TRANS PVW] button, turning it off.

Lock: Toggling the [TRANS PVW] button on and off switches between the transition preview mode and the normal mode.

Hold: The preview mode obtains only while the [TRANS PVW] button is held down.

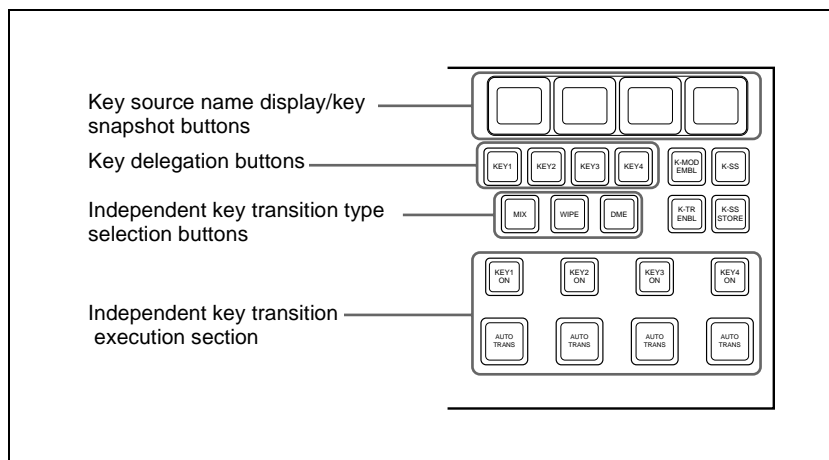
One Time: Each time a transition ends, it reverts to the normal mode.

For details of the mode setting, see “Operation Settings (Operation Menu)” and “Settings Relating to Video Switching (Transition Menu)” in Chapter 16 (Volume 2).

Notes

- During a transition, whether executed with the [AUTO TRANS] button or the fader lever, it is not possible to press the [TRANS PVW] button.
- In bus fixed mode (*see page 43*), transition previews are not available.
- When using the simple-type transition control block (*see page 255*), transition previews are not available.

Independent Key Transitions



Independent key transition control block (standard type)

To set independent transitions for the keyers on the M/E or PGM/PST bank, use the independent key transition control block.

For an overview of the independent key transitions, see page 35.

Basic Independent Key Transition Operations

In the independent key transition control block, use the following procedure.

- 1 Select one or more of the delegation buttons [KEY1] to [KEY4] ([DSK1] to [DSK4] in the PGM/PST bank), turning them on.
- 2 Select the transition type.

To fade a key in or out: Press the [MIX] button, turning it on.

To insert or delete a key using a dedicated wipe pattern: Press the [WIPE] button, turning it on.

To insert or delete a key using a dedicated DME wipe pattern: Press the [DME] button, turning it on.

If, in the Setup menus, you set insertion and deletion as independent modes, make the settings for the next transition in the independent key



transition control block.

Separate settings are required both when inserting a key and when deleting it. For example, with the key not inserted, if you select the transition type and carry out a transition, this will be the setting when inserting a key. You can also use the Transition menu to select a desired independent key transition type for each key (*see the next section*).

For details of the wipe settings, see “Wipe Settings for Independent Key Transitions” (page 322). For details of DME wipe settings, see “DME Wipe Settings for Independent Key Transitions” (page 339).

3 Execute the transition.

To insert or delete the key gradually with a mix or wipe transition:

Press the [AUTO TRANS] button.

For details of the transition rate, see “Setting the Independent Key Transition Rate” (page 250).

For details of operation together with a common transition, see “Combining other transitions with independent key transitions” (page 36).

To cut the key in or out instantaneously: Press the [KEY ON] button on the keyer.

Note

In an independent key transition, the pattern limit function is not available.

Setting the Independent Key Transition Type by a Menu Operation

You can also select the required independent key transition type by a menu operation.

Use the following procedure.

- 1 In the M/E or PGM/PST menu, select first the desired one from VF1 ‘Key1’ to VF4 ‘Key4,’ then HF6 ‘Transition.’

The Transition menu for the selected appears.

- 2 Select the required transition type in the <Transition Type> group.

If, in the Setup menus, you set insertion/deletion as independent modes, make the settings for insertion in the <On Transition Type> group, and the settings for deletion in the <Off Transition Type> group.

Setting the Independent Key Transition Rate

There are two ways of setting the transition rate: using the Flexi Pad control block or numeric keypad control block to enter a numeric value, or using the Key menu to access the Transition menu for the M/E or PGM/PST bank. When the setup selection is for separate transition rates for inserting or deleting a key, you can set both rates independently. For example, with the system in the state with the key not inserted, the transition rate setting applies to key insertion.

Setting the independent key transition rate in the Flexi Pad control block

Use the following procedure.

Note

In the PGM/PST bank or when using a simple-type transition control block, you cannot use the Flexi Pad control block to set the transition rate.

- 1** In the Flexi Pad control block of the M/E bank, hold down the [TRANS RATE] button, and in the independent key transition control block, press the delegation button [KEY1] to [KEY4] for the key for which you want to set the transition rate.

The memory recall section display is now ready to accept the entered independent key transition rate.

- 2** Enter the desired transition rate with the numeric keypad.
 - Enter a value of up to three digits.
 - To cancel the entry, press any of the six buttons in the leftmost column ([WIPE], [DME], ...) or the [TRANS RATE] button.

For details of frame input mode and timecode input mode, see page 236.

- 3** Press the [ENTR] button.

Setting the independent key transition rate in the numeric keypad control block

Use the following procedure.

Note

You cannot use the numeric keypad control block to set the transition rate for a simple transition.



- 1 In the numeric keypad control block, hold down the [TRANS RATE] button, and in the independent key transition control block, press the delegation button [KEY 1] to [KEY 4] ([DSK 1] to [DSK 4] in the PGM/PST bank) for the key for which you want to set the transition rate.

The numeric keypad control block changes to the mode for inputting the independent key transition rate, and its display now shows the corresponding region name and the current transition rate set for the region.

- 2 With the numeric keypad, enter the transition rate.
 - Enter a value of up to three digits.
 - To clear the entry value, press the [CLR] button.

For details of frame input mode and timecode input mode, see page 236.

- 3 Press the [ENTER] button.

This confirms the entry, and the selected region name and the set transition rate appear in the numeric keypad control block display.

To enter a difference from the current value

After pressing the [+/-] button, enter the difference and press the [TRIM] button.

To change the sign (+ or -), press the [+/-] button.

Setting the independent key transition rate by a menu operation

Use the following procedure.

- 1 In the M/E or PGM/PST menu, select first the desired one from VF1 'Key1' to VF4 'Key4,' then HF6 'Transition.'

The Transition menu for the selected key appears.

- 2 Select any transition type in the <Transition Type> group.

If, in the Setup menus, you set insertion/deletion as independent modes, make the settings for insertion in the <On Transition Type> group, and the settings for deletion in the <Off Transition Type> group.

- 3 Turn the knob to set the transition rate.

Knob	Parameter	Adjustment	Setting values
1	Transition Rate	Transition rate	0 to 999 (frame count)

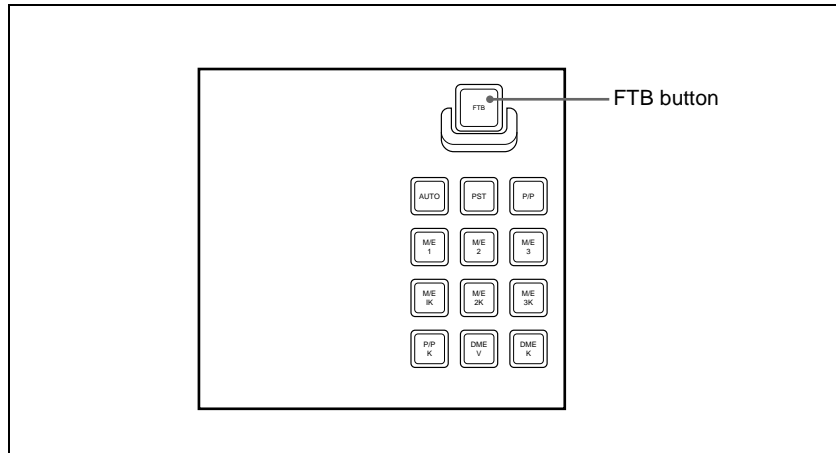
Independent key transition rate display

To check the set independent key transition rate, press the key source name display/key snapshot button above the corresponding delegation button when the [K-SS] button is off.



Fade to Black

Fade to Black Operation



Fade to black control block

Carrying out a fade to black

To carry out a fade to black, press the [FTB] button in the fade to black control block.

The fade to black is carried out with the transition rate set for the program output of the PGM/PST bank.

During the transition, the [FTB] button lights amber. When the transition completes (the video is completely black), the button lit color changes to red.

For an overview of the fade to black, see page 44.

Setting the Fade to Black Transition Rate

To set the fade to black transition rate, use the following procedure.

- 1** In the PGM/PST menu, select first VF7 'Misc,' then HF1 'Transition.'
The Transition menu appears.

2 Select [FTB].

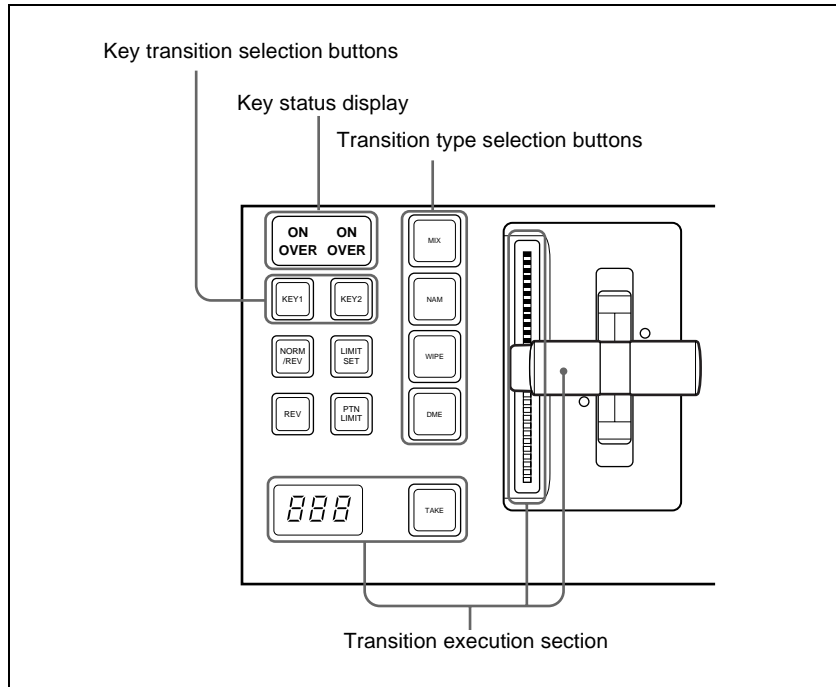
3 Turn the knob to set the fade to black transition rate.

Knob	Parameter	Adjustment	Setting values
1	Transition Rate	Transition rate	0 to 999 (frame count)



Simple Transition

The “simple transitions” refer to the transitions carried out using the simple-type transition control block (or simple-type independent key transition control block).



Transition control block (simple right-hand type)

Basic Operations for Simple Transitions

Carrying out a transition using a simple-type transition control block

Use the following procedure.



- 1 With the background A row of cross-point buttons in the cross-point control block, select the background video.
- 2 Using one of the following methods, select the way in which the transition will affect the image.
Use a combination of the transition type selection buttons ([MIX], [NAM], [WIPE] and [DME]) and the next transition selection buttons ([KEY1] and [KEY2]).

For an overview of the mix, NAM, wipe, and DME wipe transition types, see “Transition Types” (page 39).

To change the background only: Press one of the [MIX], [NAM], [WIPE], and [DME] buttons.
The [KEY1] and [KEY2] buttons go off, and the system changes to the background transition mode.

To insert or delete key 1: Hold down the [KEY1] button and press one of the [MIX], [NAM], [WIPE], and [DME] buttons.

To insert or delete key 2: Hold down the [KEY2] button and press one of the [MIX], [NAM], [WIPE], and [DME] buttons.

To insert or delete key 1 and key 2 simultaneously: Hold down the [KEY1] and [KEY2] buttons, and press one of the [MIX], [NAM], [WIPE], and [DME] buttons.

To use a super mix or preset color mix: Select [Super Mix] or [Preset Color Mix] in the Misc>Transition menu for the M/E or PGM/PST bank.

To set the key priority, use the Misc>Key Priority menu for the M/E or PGM/PST bank. For details, see “Setting the Key Priority by a Menu Operation” (page 229).

- 3 Select the new background for after the transition.
 - Select the background video with the background B row of cross-point buttons.
 - To insert a key, select the key signal, and make various settings as required.

For details of key settings, see Chapter 4 “Keys” (page 261).

- 4 Depending on the transition type selected in step 2, make the required settings.

For details of the settings, see the following sections:

Super mix: “Super Mix Settings” (page 233)

Preset color mix: “Color Matte Settings” (page 234)

Wipe: “Basic Procedure for Wipe Settings” (page 304)

DME Wipe: “Basic Procedure for DME Wipe Settings” (page 332)

5 Carry out the transition in the transition execution section.

For a gradual transition such as a mix or wipe: Press the [TAKE] button, or operate the fader lever.

See “Setting the Transition Rate” (page 236) and “Pattern Limit” (page 239) as required.

Display of the Key Output Status and Key Priority

You can check the output status of keys 1 and 2 and the key priority setting, in the key status display in the transition control block.

The key status display includes two ON indicators corresponding to keys 1 and 2.

Display of the key output status

When the key is inserted in the output from the M/E or PGM/PST bank, the indication “ON” lights, and when it is not inserted, the indication goes off.

Key priority display

The key lying in front on the program monitor has an indication “OVER” lit.

To set the key priority, use the Misc>Key Priority menu for the M/E or PGM/PST bank. For details, see “Setting the Key Priority by a Menu Operation” (page 229).

Split Fader

What does “split fader” mean?

The term “split fader” refers to the function of carrying out a transition with the fader lever split into left and right halves, so that the background A and background B buses can be manipulated separately.

To use the split fader, the following conditions must be met.

- The fader lever is in bus fixed mode. (See “Settings Relating to Video Switching (Transition Menu)” in Chapter 16 (Volume 2).)
- The necessary settings have been made in a Setup menu to enable the split fader (See “Settings Relating to Video Switching (Transition Menu)” in Chapter 16 (Volume 2).)
- A background is selected for the next transition.
- For the transition type, [MIX] or [NAM] is selected.

Split fader operation

The two halves of the split fader lever correspond to the buses as follows.

Right fader lever: Background A bus

Left fader lever: Background B bus

The relationship between the positions of the two fader levers and the image output in a mix is as follows.

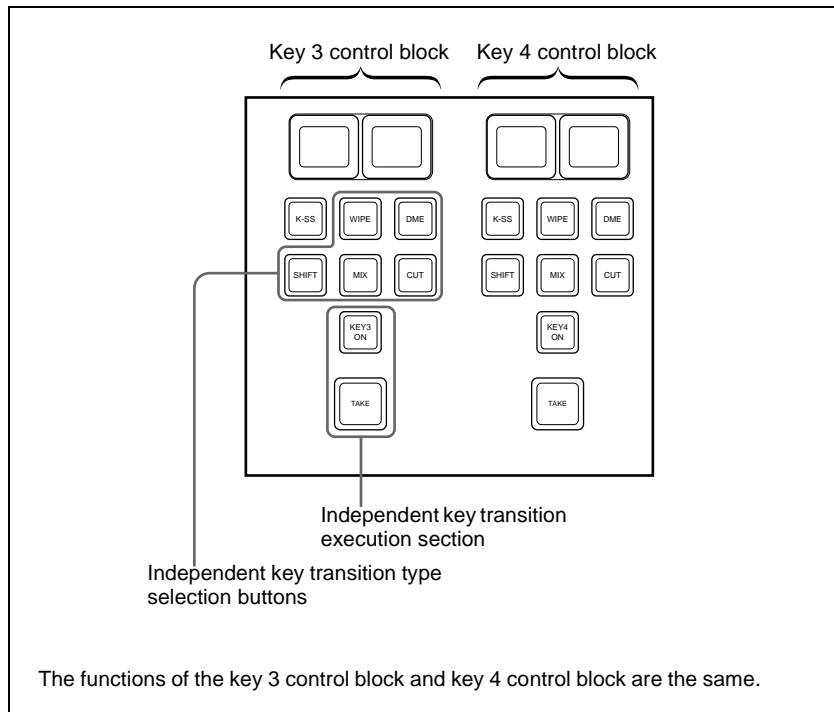
Left lever position	Right lever position	A bus output	B bus output
Top	Top	100%	0%
Bottom	Top	100%	100%
Top	Bottom	0%	0%
Bottom	Bottom	0%	100%
Center	Center	50%	50%

- When the transition type is NAM, the outputs of the A bus and B bus in the above table are the outputs subjected to NAM.
- The transition indicators always show the progress of the background A bus.
- The operation of the left lever and that of the right lever can be swapped. (See “*Operation Settings (Operation Menu)*” in Chapter 16 (Volume 2).)

Independent Key Transitions With a Simple Transition Module

You carry out independent key transition operations using the independent key transition control block (simple type). This controls only keys 3 and 4.





Independent key transition control block (simple type)

Carrying out a transition using a simple-type independent key transition control block

Use the following procedure.

- 1** Select the transition type for key 3 or key 4 using the independent key transition type selection buttons.

To fade a key in or out: Press the [MIX] button, turning it on.

To insert or delete a key using a dedicated wipe pattern: Press the [WIPE] button, turning it on.

To insert or delete a key using a dedicated DME wipe pattern: Press the [DME] button, turning it on.

For details of wipe settings, see “Wipe Settings for Independent Key Transitions” (page 322). For details of DME wipe settings, see “DME Wipe Settings for Independent Key Transitions” (page 339).

To cut the key instantaneously in or out: Press the [CUT] button, turning it on.

If, in the Setup menus, you set insertion and deletion as independent modes, make the settings for the next transition in the independent key transition control block.

Separate settings are required both when inserting a key and when deleting it. For example, with the key not inserted, if you select the transition type and carry out a transition, this will be the setting when inserting a key.

- 2** Carry out the transition in the independent key transition execution section.

To insert or delete the key gradually with a mix or wipe transition:

Press the [TAKE] button.

To set the independent key transition rate using a simple-type transition control block, use the key 3 and key 4 Transition menus. For details, see “Setting the Independent Key Transition Rate” (page 250).

To cut the key in or out instantaneously: Press the [KEY 3 ON] button or [KEY 4 ON] button.

Note

In an independent key transition, the pattern limit function is not available.



Chapter 4 Keys

Key Setting Operations Using Menus	262
Key Setting Menus	262
Key Type Setting	263
Chroma Key Composition	265
Chroma Key Adjustments	266
Selecting Key Fill and Key Source.....	271
Key Edge Modifications	273
Masks	279
Applying a DME Effect to a Key	283
Specifying the Key Output Destination.....	284
Blink Function	285
Video Processing	286
Key Setting Operations With the Key Control Block	287
Operations in the Key Control Block	287
Key Edge Modifications	291
Masks	295
Applying a DME Effect to a Key	296
Other Key Setting Operations.....	297
Key Snapshots	299
Key Snapshot Operations	299
Key Snapshot Operations Using a Simple Transition Module.....	301

Key Setting Operations Using Menus

There are two ways of making key settings: either using menus, or using the key control block.

This section describes basic procedures for making key settings using the menus, taking the M/E-1>Key1 menu as an example.

Operations in the Key menus are the same for all banks (M/E-1 to M/E-3 and PGM/PST).

For details of the method of using the key control block, see “Key Setting Operations With the Key Control Block” (page 287).

Key Setting Menus

The key setting menus for each bank (M/E-1 to M/E-3 and PGM/PST) are as follows.

Bank	Keys set	Menus
M/E-1	Keys 1 to 4	M/E-1>Key1 to 4
M/E-2	Keys 1 to 4	M/E-2>Key1 to 4
M/E-3	Keys 1 to 4	M/E-3>Key1 to 4
PGM/PST	Downstream keys 1 to 4	PGM/PST>DSK1 to 4

Accessing a key setting menu

For example, to access the M/E-1>Key1 menu, carry out any of the following procedures.

- In the menu control block, select the top menu selection button [M/E 1], then press VF1 ‘Key1.’
- In the M/E-1 bank transition control block, press the KEY1 next transition selection button twice in rapid succession.
- In the M/E-1 bank independent key transition control block, press the key delegation button [KEY1] twice in rapid succession.
- In the key control block, press the M/E delegation button [M/E 1], then press the key delegation button [KEY1] twice in rapid succession.

Any of the above operations displays the M/E1>Key1 menu.

Note that you can access the DSK menus by pressing the button for the corresponding key in the downstream key control block twice in rapid succession.

Key Type Setting

Setting the key type in a menu

Use the following procedure.

- 1** In the M/E-1>Key1 menu, select HF1 'Type.'

The Type menu appears.

- 2** In the <Key Type> group, select the key type.

Luminance: luminance key

Linear: linear key

Chroma: chroma key

Color Vector: color vector key

Wipe Pattern: wipe pattern key

Key Wipe Pattern: key wipe pattern key

For the selected key type, you can now set the parameters.

For an overview of the key types, see page 46.

- 3** Carry out the following settings as required, depending on the key type selected in step 2.

To enable clean mode (see page 47) for a luminance key, linear key or color vector key: Select [Clean Mode] so that it is set on.

When clean mode is enabled, key fill is added to the background without cutting out with key source.

When chroma key is selected: Select [Chroma Adjust] to access the Chroma Adjust menu (see page 266), and make the required settings.

When a wipe pattern key is selected: In the M/E-1>Wipe menu (see page 304), select the pattern and set any modifiers, then return to the M/E-1>Key1 menu.

When a key wipe pattern key is selected: In the M/E-1>Key1>Transition>Wipe Adjust menu (see page 322), carry out pattern selection and modifier setting, then return to the M/E-1>Key1>Type menu.

Note

For a wipe pattern selected for a wipe pattern key or key wipe pattern key, the [Edge] and [Direction] modifier settings are not available.

- 4** Set the parameters.

• **When a luminance key or linear key is selected**

Knob	Parameter	Adjustment	Setting values
1	Clip	Reference level for generating the key signal	+109.58 to -7.30
2	Gain	Key sensitivity	-100.00 to +100.00
3	Density	Key density	0.00 to 100.00
4	Filter	Filter coefficient	1 to 9 ^{a)}

a) Setting this value to 1, produces the “through” state in which no filter is applied. The larger the value, the more strongly the filter applies.

• **When a chroma key is selected**

Knob	Parameter	Adjustment	Setting values
3	Density	Key density	0.00 to 100.00

• **When a color vector key is selected**

Knob	Parameter	Adjustment	Setting values
1	Y Clip	Reference level for creating luminance signal	+109.58 to -7.30
2	Y Gain	Luminance signal sensitivity	-100.00 to +100.00
3	C Clip	Reference level for creating chrominance signal	100.00 to 0.00
4	C Gain	Chrominance signal sensitivity	-100.00 to +100.00
5	Density	Key density	0.00 to 100.00
6	Y Filter	Luminance signal filter coefficient	1 to 9
7	C Filter	Chrominance signal filter coefficient	1 to 9

• **When a wipe pattern key or key wipe pattern key is selected**

Knob	Parameter	Adjustment	Setting values
1	Size	Pattern size	0.00 to 100.00
2	Soft	Degree of edge softness	0.00 to 100.00
3	Density	Key density	0.00 to 100.00

5 Make the following settings as required.

To invert the black/white sense of the key source: Press [Key Invert], turning it on.



To adjust the horizontal position or key source width for a luminance key, linear key, or chroma key: Press [Key Position], turning it on, and set the parameters.

Knob	Parameter	Adjustment	Setting values
1	H Phase	Key horizontal position	-4.00 to +4.00
2	Left	Key left edge position	-4.00 to +4.00
3	Right	Key right edge position	-4.00 to +4.00

To set the key priority: Press [Key Priority] or select VF7 'Misc' and HF3 'Key Priority' to access the Key Priority menu.

For details, see "Setting the Key Priority by a Menu Operation" (page 229).

Chroma Key Composition

Composing an image by chroma keying

There are two types of composition for chroma keying: normal mix, and additive mix.

To carry out chroma key composition, use the following procedure.

For an overview of the chroma key composition, see page 47.

1 In the M/E-1>Key1 menu, select HF1 'Type.'

2 Select [Chroma] in the <Key Type> group.

It becomes possible to adjust the key density (*see page 264*).

3 Select [Chroma Adjust].

The Chroma Adjust menu appears.

4 Carry out auto chroma key adjustments.

Also carry out manual adjustments if necessary to obtain an optimum chroma key image.

For the adjustment procedures, see page 266.

5 In the <Mix Mode> group, select [Normal Mix] or [Additive Mix] depending on the desired type of chroma key composition.

When using an additive mix for chroma keying, the (typically blue) background parts of the foreground video must be converted to black. For this, use the color cancel function (*see page 267*).

Using the plane function

In an additive mix, since no key is applied to the foreground, any variations in the (typically blue) background may appear in the composite image. To avoid this, a particular luminance level can be set for the (blue) background, and regions of lower luminance forcibly cut.

Use the following procedure.

- 1** In the Chroma Adjust menu, set [Plane] on.
- 2** Adjust the following parameter.

Knob	Parameter	Adjustment	Setting values
1	Luminance	Luminance level	0.00 to 100.00

Chroma Key Adjustments

There are two ways of making chroma key adjustments: automatically, using the auto chroma key function, or manually, making individual adjustments such as color cancel adjustments and window adjustments.

Making auto chroma key adjustments

Auto chroma key is an automatic adjustment function which allows you to specify a part of the foreground video (for example, the blue background color) and use it as a reference for creating the chroma key image.

Use the following procedure.

- 1** In the M/E-1>Key1 menu, select HF1 'Type,' then select [Chroma] in the <Key Type> group.
- 2** Select [Chroma Adjust].
The Chroma Adjust menu appears.
- 3** Select [Sample Mark] in the <Auto> group.

The foreground video only appears on the monitor, with a white box-shaped sample selector.



- Adjust the position and size of the sample selector, to specify the color to be used as the basis of chroma keying (typically a blue background).

Knob	Parameter	Adjustment	Setting values
1	Position H	Horizontal position	-100.00 to +100.00 ^{a)}
2	Position V	Vertical position	-100.00 to +100.00 ^{a)}
3	Size	Size	1.00 to 100.00

a) The setting ranges depend on the signal format, screen aspect ratio, and size settings.

- Select [Auto Start] in the <Auto> group.

This executes an auto chroma key based on the color specified by the sample selector, and displays the composite image on the monitor.

Making key active adjustments

When the key active function is on, the composite image is output to the monitor, and you can watch the monitor while manually adjusting the keying. When the key active function is off, only the foreground image appears. Set this off when manually adjusting color cancel (*see the next section*). Use the following procedure.

- In the Chroma Adjust menu, set [Key Active] on.
- Adjust the following parameters.

Knob	Parameter	Adjustment	Setting values
1	Clip	Chroma key reference level	100.00 to 0.00
2	Gain	Key gain	-100.00 to +100.00
3	Hue	Hue	359.99 to 0.00
4	Density	Density	0.00 to 100.00
5	Filter	Filter coefficient	1 to 9

Making color cancel adjustments

If the background color is leaking into the foreground video, turning the color cancel function on allows you to eliminate this leakage. Use the following procedure.

- In the Chroma Adjust menu, turn [Key Active] off.
Only the foreground image appears on the monitor.
- In the <Color Cancel> group, set [Color Cancel] on.

3 Adjust the following parameters.

Knob	Parameter	Adjustment	Setting values
1	Luminance	Luminance	0.00 to 100.00
2	Saturation	Saturation	0.00 to 100.00
3	Hue	Hue	359.99 to 0.00
5	Filter	Filter coefficient	1 to 9

4 Set [Key Active] on.

The chroma key composite image now appears in the monitor.

Key signal adjustments for color cancel

When the color cancel function is set on, you can adjust the key signal for color cancel.

Use the following procedure.

1 In the <Color Cancel> group of the Chroma Adjust menu, set [Color Cancel] on.

2 In the <Color Cancel> group, set [Cancel Key] on.

The cancel key is now on, and you can now adjust the key signal for color cancel.

Knob	Parameter	Adjustment	Setting values
1	Clip	Color cancel key reference level	0.00 to 100.00
2	Gain	Color cancel key gain	-100.00 to +100.00

3 Make the following settings, as required, in the <Color Cancel> group.

- When setting [Key Position] on and adjusting the color cancel key edge position

Knob	Parameter	Adjustment	Setting values
1	H Phase	Move left and right edges of the color cancel key simultaneously	Left edge position value shown
2	Left	Move left edge of the color cancel key	-3.00 to +3.00
3	Right	Move right edge of the color cancel key	-3.00 to +3.00

- When setting [Window] on and adjusting the detection range of the color cancel key

Knob	Parameter	Adjustment	Setting values
1	Crop	Crop value	100.00 to 0.00
2	Angle	Angle value	180.00 to 0.00

For details of the crop and angle parameters, see “Chroma key window” (page 48).

- When setting [Y Balance] on and adjusting the ratio in which Y balance is added to the color cancel key

Knob	Parameter	Adjustment	Setting values
1	Mixture	Ratio of Y balance key	0.00 to 100.00

Adjusting the window

Setting the window function on allows you to adjust the detection range used to determine the key signal. When this function is off, the default range is used for the key.

For an overview of the window, see “Chroma key window” (page 48).

After making sure that the values of Clip, Gain, and Hue are adjusted appropriately, use the following procedure to make the window adjustment.

- 1 In the Chroma Adjust menu, set [Window] on.
- 2 Adjust the following parameters.

Knob	Parameter	Adjustment	Setting values
1	Crop	Crop value	100.00 to 0.00
2	Angle	Angle value	180.00 to 0.00

Adjusting the Y balance

Setting the Y balance on allows you to specify that, even if the hue is the same, only portions of a particular luminance will be replaced by the background.

For an overview of the Y balance, see page 49.

Use the following procedure.

- 1 In the Chroma Adjust menu, set [Y Balance] on.

2 Adjust the following parameters.

Knob	Parameter	Adjustment	Setting values
1	Clip	Luminance range	0.00 to 100.00
2	Gain	Key gain	-100.00 to +100.00
3	Luminance	Luminance	0.00 to 100.00

Adjusting the chroma key shadow

This function allows a shadow falling on the (typically blue) background color to be rendered more realistically. Since portions of the (blue) background of less than a certain luminance are treated as shadows, there is no effect on cutting out of the foreground.

Use the following procedure.

1 In the Chroma Adjust menu, set [Shadow] on.

2 Adjust the following parameters.

Knob	Parameter	Adjustment	Setting values
1	Luminance	Reference luminance for shadows	0.00 to 100.00
2	Gain	Shadow key gain	-100.00 to +100.00
3	Density	Shadow opacity	0.00 to 100.00
4	Soft	Shadow softness	0.00 to 100.00

Note

When chroma key shadow is on, key edge is changed to normal, and soft edge is switched off.

Adjusting the video signal

You can change the gain of the foreground signal, or vary the Hue. There are separate adjustments for the gain of the whole video signal, or Y and C individually.

Use the following procedure.

1 In the Chroma Adjust menu, set [FRGD CCR] on.

2 Adjust the following parameters.

Knob	Parameter	Adjustment	Setting values
1	Video Gain	Overall gain of video signal	-100.00 to +100.00
2	Y Gain	Y signal gain	-100.00 to +100.00
3	C Gain	C signal gain	-100.00 to +100.00

Knob	Parameter	Adjustment	Setting values
4	Hue	Hue offset amount	-180.00 to +180.00

Selecting Key Fill and Key Source

Selecting key fill and key source

To select key fill and key source for key 1 on the M/E-1 bank, use the following procedure.

- 1 In the M/E-1>Key1 menu, select HF1 'Type.'

The Type menu appears.

- 2 In the <Key Fill> group, select either of the following for use as key fill.

Key Bus: signal selected on the key 1 fill bus

Matte: signal from the dedicated color matte generator

- 3 If you selected [Key Bus] in step 2, select the key fill signal on the key 1 row in the cross-point control block.

To select key fill for key 3 or key 4 in the cross-point control block, press the [KEY3] button or [KEY4] button to the right of the key bus buttons, turning it on, to allocate the key 1 row or key 2 row to the key 3 fill or key 4 fill, then press the desired cross-point button.

- 4 If you selected [Matte] in step 2, in the same Type menu, press the [Matte Adjust] button to display the Matte Adjust menu, then adjust the single-color or two-color combination color matte. Select whether to use a single-color matte or a two-color combination in the <Fill Matte> group.

Flat Color: Adjust color 1 with the following parameters.

Knob	Parameter	Adjustment	Setting values
1	Luminance	Luminance	0.00 to 100.00
2	Saturation	Saturation	0.00 to 100.00
3	Hue	Hue	359.99 to 0.00

Mix Color: Carry out a color mix. Adjust color 1 and color 2, and select a mix pattern (*see the next section*).

- 5 In the <Key Source> group, specify the key source selection mode.

Self: The key fill bus signal is automatically selected as the key source. When the key type is selected as chroma key, select [Self].

Auto Select: The signal allocated, being paired with the key fill bus signal, to a cross-point button is automatically selected as the key source. The setting of key fill and key source pairs is carried out in the Setup menu. (See “Cross-Point Settings (Xpt Assign Menu)” in Chapter 16 (Volume 2).)

Split: You can select a key source signal independently of the key source automatically selected in Auto Select mode.

- 6 When [Split] was selected in step 5, hold down the [SPLIT] button in the key control block, then in the cross-point control block key 1 row, select the key source signal.

Note

When [Split] is selected, the key memory function (see page 54) is disabled.

Carrying out a color mix for key fill

When [Matte] is selected for key fill, you can combine color 1 and color 2. For the combination, you can use not only a key wipe generator pattern, but also the dedicated pattern for key edge color mix.

Use the following procedure.

- 1 In the <Key Fill> group of the Type menu, select [Matte] and press [Matte Adjust].

The Matte Adjust menu appears.

- 2 Select [Mix Color] in the <Fill Matte> group.

- 3 Adjust the following parameters.

Knob	Parameter	Adjustment	Setting values
1	Size	Pattern size	0.00 to 100.00
2	Soft	Softness of the edge of the pattern	0.00 to 100.00

- 4 Select the combining pattern in the <Mix Pattern> group.

Key Wipe: The wipe pattern selected for an independent key transition is used for combination.

Edge Pattern: Combine using the dedicated pattern selected for the color mix in the key edge fill.

For details, see “Carrying out a color mix for the key edge fill matte” (page 277).



- 5** In the Type menu, adjust color 1 and color 2.

To adjust color 1, select [Color1], and to adjust color 2, select [Color2], then adjust the following parameters.

Knob	Parameter	Adjustment	Setting values
1	Luminance	Luminance	0.00 to 100.00
2	Saturation	Saturation	0.00 to 100.00
3	Hue	Hue	359.99 to 0.00

- 6** To interchange color 1 and color 2, press the [Color Invert] button, turning it on.

Key Edge Modifications

To modify the key edge of key 1 on the M/E-1 bank, use the following procedure.

- 1** In the M/E-1>Key1 menu, select HF2 ‘Edge.’

The Edge menu appears.

- 2** Select the edge type in the <Edge> group.

For an overview of the key edge modifications, see “Edge modifiers” (page 50).

Normal: unadorned edge

Border: edge with border applied

Drop Border: edge with drop border applied

Shadow: edge with shadow applied

Outline: edge used as outline

Emboss: embossing effect applied to edge

If you select [Normal], skip to step **7**.

- 3** Set the border width and other parameters.

When border or outline is selected: The setting parameters depend on the key type and whether the separate edge function is enabled or not. To enable the separate edge function, press [Separate Edge], setting it on.

• Separate edge off

Knob	Parameter	Adjustment	Setting values
1	Width	Width	0.00 to 8.00 ^{a)} (0.00 to 100.00) ^{b)}
3	Density	Density	0.00 to 100.00

a) In the “4H mode” and when [Fine Key] (page 276) is on, the setting value range is 0.00 to 4.00.

b) When a wipe pattern key or key wipe pattern key is selected as the key type

• Separate edge on

The left, right, top, and bottom border or outline widths can be adjusted independently. The separate edge function is only valid when a luminance key, linear key, or chroma key is selected as the key type.

Knob	Parameter	Adjustment	Setting values
1	Top	Top edge width	0.00 to 8.00 ^{a)}
2	Left	Left edge width	0.00 to 8.00 ^{a)}
3	Right	Right edge width	0.00 to 8.00 ^{a)}
4	Bottom	Bottom edge width	0.00 to 8.00 ^{a)}
5	Density	Density	0.00 to 100.00

a) In the “4H mode” and when [Fine Key] (page 276) is on, the setting value range is 0.00 to 4.00.

When drop border or shadow is selected: The setting parameter values depend on the on/off setting of key drop and the selection of 4H mode/8H mode (*see page 52*).

• “Key drop OFF” mode

Knob	Parameter	Adjustment	Setting values
1	Width	Width	0.00 to 8.00
2	Position	Position	359.99 to 180.00
3	Density	Density	0.00 to 100.00

• “Key drop ON” mode

Knob	Parameter	Adjustment	Setting values
1	Width	Width	0.00 to 8.00 ^{a)}
2	Position	Position	359.99 to 0.00
3	Density	Density	0.00 to 100.00

a) In the “4H mode” and when [Fine Key] (page 276) is on, the setting value range is 0.00 to 4.00.



When emboss is selected:

Knob	Parameter	Adjustment	Setting values
1	Width	Width	0.00 to 4.00
2	Position	Position	359.99 to 0.00
3	Density ^{a)}	Density	0.00 to 100.00

a) The Density adjustment only affects the key edge. This can be adjusted separately from Key Density, and if Key Density is set to 0.00, the embossed edge effect only can be applied.

To make edge fill adjustments, carry out the settings in step 6.

4 Select the edge fill signal in the <Edge Fill> group.

Utility 1 Bus: signal selected on the utility 1 bus

Matte: signal from dedicated color matte generator.

It becomes possible to adjust color 1.

Knob	Parameter	Adjustment	Setting values
1	Luminance	Luminance	0.00 to 100.00
2	Saturation	Saturation	0.00 to 100.00
3	Hue	Hue	359.99 to 0.00

When the edge type is outline, in place of the edge fill signal, the selected key fill signal fills the outline, and elsewhere remains as the background.

5 Carry out the following operation, depending on the selection in step 4.

When [Utility 1 Bus] is selected: Hold down the [UTIL] button in the cross-point control block, and select the signal in the background A bus row.

While the [UTIL] button is held down, the background A bus changes to the utility 1 bus.

Note

To enable the [UTIL] button, its operation mode must be set to [Hold] beforehand. (See “Operation Settings (Operation Menu)” in Chapter 16 (Volume 2).)

When [Matte] is selected: Press [Matte Adjust] in the same EDGE menu, to display the Matte Adjust menu, and adjust a single color or two-color combination color matte.

You can select whether to use a single color matte or a two-color combination color matte in the <Edge Matte> group.

For the color mix operation, see “Carrying out a color mix for the key edge fill matte” (page 277).

- 6** When emboss is selected for the edge type, adjust the color in the <Emboss Fill> group.

To adjust matte 1 press [Matte1], and to adjust matte 2 press [Matte2], then adjust the following parameters.

Knob	Parameter	Adjustment	Setting values
1	Luminance	Luminance	0.00 to 100.00
2	Saturation	Saturation	0.00 to 100.00
3	Hue	Hue	359.99 to 0.00

- 7** To make the edge soft, press [Soft Edge] to set it on, and adjust the softness.

Knob	Parameter	Adjustment	Setting values
1	Soft	Edge softness	0.00 to 100.00

For a normal edge, when [Soft Edge] is enabled, [Key Drop] is kept on.

- 8** To make separate fine adjustments to the positions of the left, right, top, and bottom of the source edge, press [Fine Key], to set it on, and adjust the following parameters.

Knob	Parameter	Adjustment	Setting values
1	Top	Key top edge position	-2.00 to +2.00
2	Left	Key left edge position	-2.00 to +2.00
3	Right	Key right edge position	-2.00 to +2.00
4	Bottom	Key bottom edge position	-2.00 to +2.00
6	H Phase	Key horizontal position	Left edge position value shown
7	V Phase	Key vertical position	Top edge position value shown

Note

In the emboss function it is not possible to set [Fine Key] on.

- When the edge type is normal, drop border or shadow, enabling the [Fine Key] function keeps [Key Drop] on.
- When applying a border to the key edge, enabling the [Fine Key] function halves the border width setting range.



Carrying out a color mix for the key edge fill matte

When you select 'Matte' for the edge fill of a border, drop border, or shadow, you can create a combination of color 1 and color 2 using a wipe pattern generated by the dedicated pattern generator.

Use the following procedure.

- 1 In the <Edge Fill> group of the Edge menu, select [Matte], then press [Matte Adjust].

The edge fill Matte Adjust menu appears.

- 2 In the <Edge Matte> group, select [Mix Color], turning it on.

- 3 Adjust the following parameters.

Knob	Parameter	Adjustment	Setting values
1	Size	Pattern size	0.00 to 100.00
2	Softness	Softness of pattern edge	0.00 to 100.00
3	Pattern	Pattern number	1 to 24 ^{a)}

a) The patterns are the same as standard wipes. (For details, see the appendix "Wipe Pattern List" (Volume 2).)

To select the pattern, display the Mix Pattern Select menu by pressing [Mix Pattern] in the edge fill Matte Adjust menu. After selecting one of the patterns (standard wipe patterns 1 to 24) displayed in the Mix Pattern Select menu, you can adjust the following parameters.

Knob	Parameter	Adjustment	Setting values
1	Size	Pattern size	0.00 to 100.00
2	Softness	Softness of pattern edge	0.00 to 100.00

- 4 Adjust color 1 and color 2.

To adjust color 1 press [Color 1], and to adjust color 2 press [Color 2], turning it on respectively, and adjust the following parameters.

Knob	Parameter	Adjustment	Setting values
1	Luminance	Luminance	0.00 to 100.00
2	Saturation	Saturation	0.00 to 100.00
3	Hue	Hue	359.99 to 0.00

- 5 If required, set the pattern modifiers.

- When turning [Position] on and setting the pattern position

Knob	Parameter	Adjustment	Setting values
1	Position H	Horizontal position	-200.00 to +200.00 ^{a)}
2	Position V	Vertical position	-200.00 to +200.00 ^{a)}

a) See page 61.

- When turning [Multi] on and replicating the pattern

Knob	Parameter	Adjustment	Setting values
1	H Multi	Number of repetitions of pattern horizontally	1 to 63
2	V Multi	Number of repetitions of pattern vertically	1 to 63
3	Invert Type	Replication layout	1 to 4 ^{a)}

a) See page 64.

- When turning [Aspect] on and setting the aspect ratio of the pattern

Knob	Parameter	Adjustment	Setting values
1	Aspect	Aspect ratio	-100.00 to +100.00 ^{a)}

a) See page 63.

- When turning [Angle] on in the <Rotation> group and inclining the pattern

Knob	Parameter	Adjustment	Setting values
1	Angle	Angle of pattern rotation	-100.00 to +100.00 ^{a)}

a) See page 61.

- When turning [Speed] on in the <Rotation> group and rotating the pattern at a constant speed

Knob	Parameter	Adjustment	Setting values
1	Speed	Rotation rate of pattern	-100.00 to +100.00 ^{a)}

a) See page 62.

6 To interchange color 1 and color 2, press [Color Invert], turning it on.

Applying the zabton effects

Use the following procedure.



1 In the Edge menu, press [Zabton], turning it on.

2 Adjust the following parameters.

Knob	Parameter	Adjustment	Setting values
1	Size	Pattern size	0.00 to 100.00
2	Soft	Pattern edge softness	0.00 to 100.00
3	Density	Density	0.00 to 100.00

Note

If in the pattern selection described below you select “Mask Pattern,” and “Box” for the main mask, the “Size” parameter here cannot be adjusted. Set “Size” in the Main Mask menu.

3 To adjust the pattern and color, press [Zabton Adjust].

The Zabton Adjust menu appears.

4 In the <Zabton Pattern> group, select the pattern.

Key Wipe: Use a key wipe.

Edge Pattern: Use a color mixing pattern for key edge.

Mask Pattern: Use the main mask Box or Pattern.

5 To adjust the color, press [Zabton Color] and adjust the following parameters.

Knob	Parameter	Adjustment	Setting values
1	Luminance	Luminance	0.00 to 100.00
2	Saturation	Saturation	0.00 to 100.00
3	Hue	Hue	359.99 to 0.00
4	Density	Density	0.00 to 100.00

Masks

There are two masks, which can be used to mask off unneeded parts of a key or background, or to remove defects, and these are known as the main mask and subsidiary mask. You can either use the main mask and subsidiary mask independently, or at the same time.

For an overview of the masks, see page 53.

Using the main mask

For example, to use the main mask for key 1 on the M/E-1 bank, use the following procedure.

1 In the M/E-1>Key1 menu, select HF3 ‘Main Mask.’

The Main Mask menu appears.

2 In the <Mask Type> group, select the mask type.

Key Mask: Masks a part of a key.

Bkgd Mask: Masks a part of a background.

3 In the <Mask Source> group, select the mask source.

Box: signal from the dedicated box generator

Pattern: signal from the dedicated pattern generator

4 Set the mask source parameters.

• When a box is selected

Knob	Parameter	Adjustment	Setting values
1	Top	Top position	-100.00 to +100.00
2	Left	Left position	-100.00 to +100.00
3	Right	Right position	-100.00 to +100.00
4	Bottom	Bottom position	-100.00 to +100.00
5	Soft	Box softness	0.00 to 100.00

• When a pattern is selected

Knob	Parameter	Adjustment	Setting values
1	Size	Pattern size	0.00 to 100.00
2	Soft	Edge softness	0.00 to 100.00
5	Pattern	Pattern number	1 to 24 ^{a)}

a) The pattern is the same as a standard wipe. (See the appendix “Wipe Pattern List” (Volume 2).)

To select the pattern, display the Mask Ptn Select menu by pressing the [Mask Ptn Select] button in the Main Mask menu. After selecting one of the patterns (standard wipe patterns 1 to 24) displayed in the Mask Ptn Select menu, you can adjust the following parameters.

Knob	Parameter	Adjustment	Setting values
1	Size	Pattern size	0.00 to 100.00

Knob	Parameter	Adjustment	Setting values
2	Soft	Edge softness	0.00 to 100.00

- 5** To invert the black/white sense of the mask source, press the [Mask Invert] button, turning it on.
- 6** When a pattern is selected as the mask source, set the pattern modifiers as required.

• **When turning [Position] on and setting the pattern position**

Knob	Parameter	Adjustment	Setting values
1	Position H	Horizontal position	-200.00 to +200.00 ^{a)}
2	Position V	Vertical position	-200.00 to +200.00 ^{a)}

a) See page 61.

• **When turning [Multi] on and replicating the pattern**

Knob	Parameter	Adjustment	Setting values
1	H Multi	Number of repetitions of pattern horizontally	1 to 63
2	V Multi	Number of repetitions of pattern vertically	1 to 63
3	Invert Type	Replication layout	1 to 4 ^{a)}

a) See page 64.

• **When turning [Aspect] on and setting the aspect ratio of the pattern**

Knob	Parameter	Adjustment	Setting values
1	Aspect	Aspect ratio	-100.00 to +100.00 ^{a)}

a) See page 63.

• **When turning [Angle] on in the <Rotation> group and setting the angle of the pattern rotation**

Knob	Parameter	Adjustment	Setting values
1	Angle	Pattern angle	-100.00 to +100.00 ^{a)}

a) See page 61.

- When turning [Speed] on in the <Rotation> group and setting the rate of pattern rotation

Knob	Parameter	Adjustment	Setting values
1	Speed	Rate of pattern rotation	-100.00 to +100.00 ^{a)}

a) See page 62.

Using the subsidiary mask

For example, to use the subsidiary mask for key 1 on the M/E-1 bank, use the following procedure.

- 1 In the M/E-1>Key1 menu, select HF4 'Sub Mask.'

The Sub Mask menu appears.

- 2 In the <Mask Type> group, select the mask type.

Key Mask: Masks a part of a key.

Bkgd Mask: Masks a part of a background.

- 3 In the <Mask Source> group, select the mask source.

Wipe: wipe pattern selected for a transition

If you select [Wipe], select the pattern and make modifier settings in the M/E-1>Wipe menu (*see page 304*), then return to this M/E-1>Key1 menu.

In the case of a wipe pattern selected for a mask, the modifier [Edge] and [Direction] settings are not available.

Utility 1 Bus: signal selected on the utility 1 bus

When you selected [Utility 1 Bus], hold down the [UTIL] button in the M/E-1 bank cross-point control block, and select the signal with the background A bus buttons. While the [UTIL] button is pressed, the background A bus switches to the utility 1 bus.

Note

To enable the [UTIL] button, its operation mode must be set to [Hold] beforehand. (*See "Operation Settings (Operation Menu)" in Chapter 16 (Volume 2).*)

- 4 Set the mask source parameters.

- When wipe is selected

Knob	Parameter	Adjustment	Setting values
1	Size	Pattern size	0.00 to 100.00



Knob	Parameter	Adjustment	Setting values
2	Soft	Edge softness	0.00 to 100.00

• **When utility 1 bus is selected**

Knob	Parameter	Adjustment	Setting values
1	Clip	Reference level for creating mask signal	+109.58 to -7.30
2	Gain	Gain	-100.00 to +100.00

- 5** To invert the black/white sense of the mask source, press the [Mask Invert] button, turning it on.

Applying a DME Effect to a Key

Assigning a DME to a key

Use the following procedure.

- 1** In the M/E-1 >Key1 menu, select HF5 ‘Processed Key.’

The Processed Key menu appears.

- 2** In the <DME Select> group, select the DME channel (DME1 to DME4) to be used.

The lit colors of [DME1] to [DME4] indicate the DME assignment.

Lit green: Shows the DME assigned to the currently selected key.

Lit amber: Shows the DME assigned to a key other than the currently selected key.

Off: DME is not assigned.

To select a DME being used by another keyer

Press [Override], turning it on, then select the DME channel.

The later selection is valid, and the button lights green.

Using two or three DME channels on one keyer

Use the following procedure.

- 1** Select the DME for the first channel (*see the previous item, “Assigning a DME to a key”*), then select the successive channel for the second channel. For the third channel select the channel after that.

- 2 To select the video signal for the second channel, hold down the [UTIL] button in the cross-point control block, and select the signal in the Key1 row (DME external video bus).
- 3 To select the video signal for the third channel, hold down the [UTIL] button in the cross-point control block, and carry out the following operation.

If the selected DME is channel 3 or channel 4, turn off the [KEY4] button in the key 2 row, then select the signal in the key 2 row (DME utility 1 bus).

Assigning a DME output signal as a monitor signal

Use the following procedure.

- 1 In the Processed Key menu, press [Monitor].
The Monitor menu appears.
- 2 Press [Monitor Set], turning it on.
- 3 In the <DME Select> group, select the DME channel (DME1 to DME4) to be used.

This assigns the selected DME output to DME MON V and DME MON K. The colors with which [DME1] to [DME4] are lit show the key assignment status.

Lit green: DME currently being monitored

Lit amber: DME that can be monitored

Off: Unassigned DME

Specifying the Key Output Destination

Using the key processed keyer signals (external processed key)

To select the key processed keyer key fill and key source signals on the AUX buses, press [Ext Proc Key], turning it on, in the Processed Key menu.

This assigns the key fill and key source signals for M/E-1 key 1 to reentry signals PROC V and PROC K.

Note

You cannot select the PROC V and PROC K signals using the cross-point selection buttons of the M/E or PGM/PST bank.

Using the key processed keyer signals or signals to which a DME effect is applied in frame memory (frame memory feed)

To use the key processed keyer key fill and key source signals on the frame memory source buses, in the Processed Key menu, press [FM Feed]. [Ext Proc Key] turns on, and the key fill and key source signals processed on the currently selected keyer are automatically assigned to frame memory source buses 1 and 2. When a DME is selected on the keyer, the key fill and key source signals to which a DME effect is applied are assigned.

Blink Function

With the blink function, you can obtain the following effects.

Key blink: The key is alternately inserted and deleted at regular intervals. You can set the period of blinking, and the proportion of each cycle for which the key is inserted.

Edge blink: The key fill and key edge fill signals are interchanged at regular intervals. You can set the period of blinking, and the proportion of each cycle for which the original state holds.

Using the blink function

For example, to make the required settings for key 1 on the M/E-1 bank, use the following procedure.

- 1** In the M/E-1>Key1 menu, select HF6 ‘Transition.’
The Transition menu appears.
- 2** In the <Blink> group, select [Key Blink] or [Edge Blink] to set it on.
- 3** Set the blink parameters.

- **When key blink is selected**

Knob	Parameter	Adjustment	Setting values
1	Blink Rate	Length of blink cycle	1 to 100
2	Duty	Proportion of cycle for which key inserted	0.00 to 100.00

- **When edge blink is selected**

Knob	Parameter	Adjustment	Setting values
1	Blink Rate	Length of blink cycle	1 to 100

Knob	Parameter	Adjustment	Setting values
2	Duty	Proportion of cycle for which original state holds	0.00 to 100.00

Video Processing

You can adjust the luminance and hue of the selected key fill signal. For example, to apply video processing to the signal selected on the M/E-1 bank key 1 fill bus, use the following procedure.

- 1** In the M/E-1>Key1 menu, select HF7 'Video Process.'
The Video Process menu appears.
- 2** Press [Video Process], turning it on.
- 3** Adjust the following parameters.

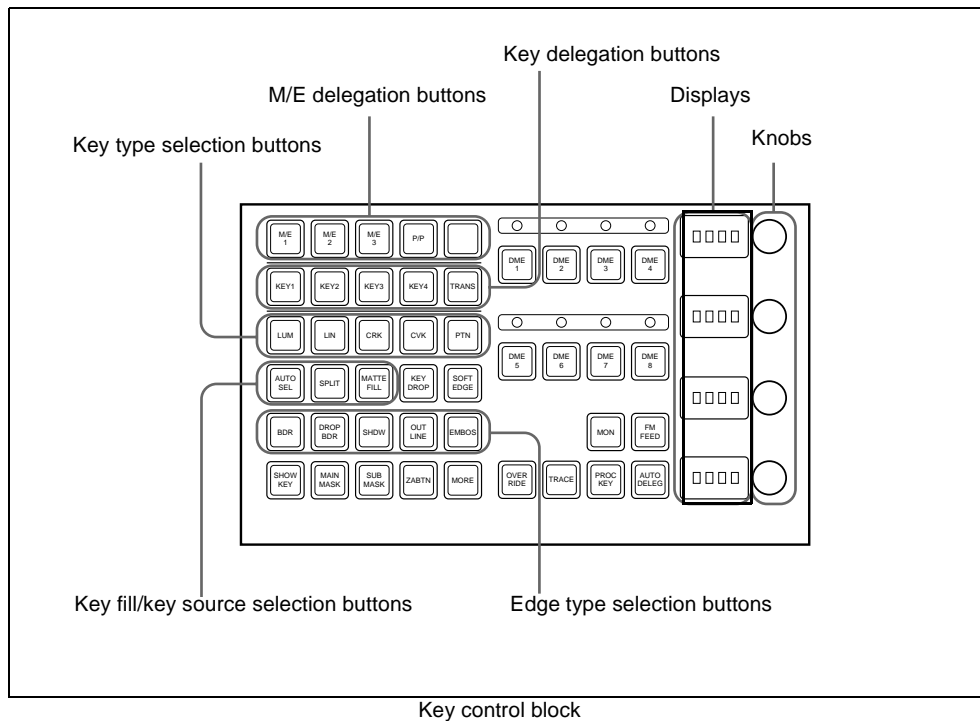
Knob	Parameter	Adjustment	Setting values
1	Video Gain	Video gain	-200.00 to +200.00
2	Y Gain	Luminance gain	-200.00 to +200.00
3	C Gain	Chrominance gain	-200.00 to +200.00
4	Hue Delay	Hue delay	-180.00 to +180.00
5	Black Level	Luminance black level	-7.30 to +109.58

To return adjustment values to their defaults

Press [Unity].

Key Setting Operations With the Key Control Block

This section describes the basic procedures for key settings using the key control block.



Operations in the Key Control Block

Selecting the bank and keyer

To make key settings, first select the bank (from M/E-1 to M/E-3 and PGM/PST) and keyer, then assign them to the key control block.

For example, to set key 1 on M/E-1 with the key control block, use the following procedure.

- 1 Using the M/E delegation buttons in the key control block, press the [M/E1] button, setting it on.
- 2 Using the key delegation buttons in the key control block, press the [KEY1] button, setting it on.

This assigns the key control block to M/E-1 key 1.

Parameter adjustment with the knobs

When the button for a function requiring parameter settings is pressed (that is, on), you can set the parameters with the four knobs. If there are more than four values to be assigned to the knobs, the [MORE] button lights amber. At this point, press the [MORE] button, which turns green, to assign the fifth and subsequent parameters to the knobs, so that the parameter settings can be made.

Selecting the key type

To select the key type, press one of the key type selection buttons in the key control block.

[LUM] button: luminance key

[LIN] button: linear key

[CRK] button: chroma key

[CVK] button: color vector key

[PTN] button: key wipe pattern key

When using a wipe pattern key as the key type, in the <Key Type> group of the Type menu for the keyer, select [Wipe Pattern] and make the settings.

For an overview of the key types, see page 46.

The button you pressed lights green, and you can now adjust the parameters with the knobs. The display beside each knob shows the first letter of the parameter name and the three-digit setting value.

• When the [LUM] or [LIN] button is lit green

Knob	Parameter	Adjustment	Setting values
1	Clip	Reference level for generating the key signal	+109 to -7
2	Gain	Key sensitivity	-100 (shown as -00) to +100
3	Density	Key density	0 to 100
4	Filter	Filter coefficient	1 to 9

• **When the [CRK] button is lit green**

Knob	Parameter	Adjustment	Setting values
1	Clip	Chroma key reference level	0 to 100
2	Gain	Key sensitivity	-100 (shown as -00) to +100
3	Hue	Hue	0 to 359
4	Density	Key density	0 to 100

- When [Key Active] is off, only the parameters Hue and Density are displayed.
- When both [Key Active] and [Color Cancel] are off, only the parameter Density is displayed.

• **When the [CVK] button is lit green**

Knob	Parameter	Adjustment	Setting values
1	Y Clip	Reference level for Y signal	+109 to -7
2	Y Gain	Y signal sensitivity	-100 (shown as -00) to +100
3	C Clip	Reference level for chrominance signal	100 to 0
4	C Gain	Chrominance signal sensitivity	-100 (shown as -00) to +100
5	Y Filter	Y signal filter coefficient	1 to 9
6	C Filter	Chrominance signal filter coefficient	1 to 9
8	Density	Key density	0 to 100

• **When the [PTN] button is lit green**

Knob	Parameter	Adjustment	Setting values
1	Size	Pattern size	0 to 100
2	Soft	Edge softness	0 to 100
3	Density	Key density	0 to 100

Selecting key fill

Select whether to use a color matte as key fill, or the signal on the key fill bus.

When using a color matte: Press the [MATTE FILL] button, setting it on. The button lights green, and you can now set the parameters with the knobs.

Knob	Parameter	Adjustment	Setting values
1	Luminance	Color 1 luminance	0 to 100
2	Saturation	Color 1 saturation	0 to 100

Knob	Parameter	Adjustment	Setting values
3	Hue	Color 1 hue	359 to 0

When [Mix Color] is selected in the key fill Matte Adjust menu, you can further adjust color 2.

When [Mix Color] is on, and the [MORE] button is lit amber

Knob	Parameter	Adjustment	Setting values
1	Luminance	Color 1 luminance	0 to 100
2	Saturation	Color 1 saturation	0 to 100
3	Hue	Color 1 hue	359 to 0
4	Size	Pattern size	0 to 100

When [Mix Color] is on, and the [MORE] button is lit green

Knob	Parameter	Adjustment	Setting values
1	Luminance	Color 2 luminance	0 to 100
2	Saturation	Color 2 saturation	0 to 100
3	Hue	Color 2 hue	359 to 0
4	Soft	Edge softness	0 to 100

When using the key fill bus signal: Press the [MATTE FILL] button, turning it off. To select the key fill signal, use the key 1 or key 2 bus buttons in the cross-point control block.

To select the key fill signal for key 3 or key 4 in the cross-point control block, press the [KEY3] button or [KEY4] button to the right of the key bus buttons, turning it on, to allocate the key 1 bus row or key 2 bus row to the key 3 fill or key 4 fill, then press the desired cross-point button.

Selecting key source

- To use the key source paired with the key fill signal selected on the key fill bus, press the [AUTO SEL] button, turning it on. The pairing of the cross-point buttons for key fill and key source is carried out in the Setup menu. (See “Cross-Point Settings (Xpt Assign Menu)” in Chapter 16 (Volume 2).)
- To select key source independently of the key fill signal selected on the key fill bus and paired with key source, hold down the [SPLIT] button, turning it on, then press the desired Key 1 or Key 2 button in the cross-point control block.
- To use as key source the same signal as the key fill signal selected on the key fill bus, select the SELF mode by pressing the [AUTO SEL] button and [SPLIT] button simultaneously so that both are off. When chroma key is selected as the key type, select the SELF mode.

Key Edge Modifications

To apply a modification to the key edge, press one of the edge type selection buttons in the key control block.

[BDR] button: border

[DROP BDR] button: drop border

[SHDW] button: shadow

[OUTLINE] button: outline

[EMBOS] button: emboss

For an overview of the edge modifications, see page 50.

The pressed button lights green, and you can now adjust the parameters with the knobs. The display beside each knob shows the first letter of the parameter name and the three-digit setting value.

Setting the border parameters

When the [BDR] button is lit green, the parameter settings depend on the key type and whether the separate edge function is active. To activate the separate edge function, press [Separate Edge], setting it on, in the Edge menu for the key.

• Separate edge off

Knob	Parameter	Adjustment	Setting values
1	Width	Border width	0 to 8 ^{a)} (0 to 100) ^{b)}
4	Density	Border density	0 to 100

a) In the “4H mode” and when [Fine Key] (page 276) is on, the setting value range is 0 to 4.

b) When a wipe pattern key or key wipe pattern key is selected as the key type

• Separate edge on

The border width settings can be made independently for left, right, top, and bottom sides. The separate edge function is only available when luminance key, linear key, or chroma key is selected as the key type.

Knob	Parameter	Adjustment	Setting values
1	Top	Top edge width	0 to 8 ^{a)}
2	Left	Left edge width	0 to 8 ^{a)}
3	Right	Right edge width	0 to 8 ^{a)}
4	Bottom	Bottom edge width	0 to 8 ^{a)}

a) In the “4H mode” and when [Fine Key] (page 276) is on, the setting value range is 0 to 4.

To adjust the edge fill color

When [BDR] is selected, the [MORE] button lights amber. Pressing the [MORE] button to turn it green then allows you to adjust the edge fill color parameters with the knobs.

Knob	Parameter	Adjustment	Setting values
1	Luminance	Luminance	0 to 100
2	Saturation	Saturation	0 to 100
3	Hue	Hue	359 to 0
4	Density	Density	0 to 100

Setting the drop border or shadow parameters

When the [DROP BDR] or [SHDW] button is lit green, the parameter settings differ between the “key drop OFF” and “key drop ON” modes (*see page 52*) as shown below. Switching between these two modes is made by turning the [KEY DROP] button on or off.

• “Key drop OFF” mode

Knob	Parameter	Adjustment	Setting values
1	Width	Width	0 to 8 ^{a)}
2	Position	Position	359 to 180
4	Density	Density	0 to 100

a) In the “4H mode” and when [Fine Key] (page 276) is on, the setting value range is 0 to 4.

• “Key drop ON” mode

Knob	Parameter	Adjustment	Setting values
1	Width	Width	0 to 8 ^{a)}
2	Position	Position	359 to 0
4	Density	Density	0 to 100

a) In the “4H mode” and when [Fine Key] (page 276) is on, the setting value range is 0 to 4.

To adjust the edge fill color

When [DROP BDR] or [SHDW] is selected, the [MORE] button lights amber. Pressing the [MORE] button to turn it green then allows you to adjust the edge fill color parameters with the knobs.

Knob	Parameter	Adjustment	Setting values
1	Luminance	Luminance	0 to 100
2	Saturation	Saturation	0 to 100
3	Hue	Hue	359 to 0



Knob	Parameter	Adjustment	Setting values
4	Density	Density	0 to 100

Setting the outline parameters

When the [OUTLINE] button is lit green, the parameter settings depend on the key type and whether the separate edge function is active. To activate the separate edge function, press [Separate Edge], setting it on, in the Edge menu for the key.

• Separate edge off

Knob	Parameter	Adjustment	Setting values
1	Width	Outline width	0 to 8 ^{a)} (0 to 100) ^{b)}
4	Density	Outline density	0 to 100

- a) In the “4H mode” and when [Fine Key] (page 276) is on, the setting value range is 0 to 4.
b) When a wipe pattern key or key wipe pattern key is selected as the key type

• Separate edge on

The outline width settings can be made independently for left, right, top, and bottom sides. The separate edge function is only available when luminance key, linear key, or chroma key is selected as the key type.

Knob	Parameter	Adjustment	Setting values
1	Top	Top edge width	0 to 8 ^{a)}
2	Left	Left edge width	0 to 8 ^{a)}
3	Right	Right edge width	0 to 8 ^{a)}
4	Bottom	Bottom edge width	0 to 8 ^{a)}

- a) In the “4H mode” and when [Fine Key] (page 276) is on, the setting value range is 0 to 4.

When [Outline] is selected with separate edge on, the [MORE] button lights amber. Pressing the [MORE] button to turn it green then allows you to adjust the key fill density parameter with a knob.

Knob	Parameter	Adjustment	Setting values
4	Density	Outline density	0 to 100

Setting the embossing parameters

When the [EMBOS] button is lit green, adjust the following parameters.

Knob	Parameter	Setting values
1	Width	0 to 4

Knob	Parameter	Setting values
2	Position	359 to 0
4	Density	0 to 100

Selecting a normal edge

When all five edge type selection buttons are off, a normal edge is selected. If one of the buttons is lit, press it, turning it off.

Softening the edge

Press the [SOFT EDGE] button, turning it on. The button lights green, and you can now adjust the softness with the knob.

Knob	Parameter	Adjustment	Setting values
1	Soft	Edge softness	0 to 100

- For a normal edge, when [SOFT EDGE] is enabled, “Key Drop” mode turns on.
- When a luminance key or linear key is selected as the key type, and clean mode is enabled, enabling [SOFT EDGE] ends the clean mode.

Applying the zabton effects

When the [ZABTN] button is lit green, adjust the following parameters.

Knob	Parameter	Adjustment	Setting values
1	Size	Pattern size	0 to 100
2	Soft	Pattern edge softness	0 to 100

Press the [MORE] button lit amber, changing it to green, then adjust the following parameters.

Knob	Parameter	Adjustment	Setting values
1	Luminance	Luminance	0 to 100
2	Saturation	Saturation	0 to 100
3	Hue	Hue	359 to 0
4	Density	Density	0 to 100



Masks

Using the main mask

In the key control block, press the [MAIN MASK] button, turning it on. The parameter settings depend on the mask source selected as [Box] or [Pattern] in the <Mask Source> group of the Main Mask menu for the key.

• When box is selected

Knob	Parameter	Adjustment	Setting values
1	Top	Top position	-100 (shown as -00) to +100
2	Left	Left position	-100 (shown as -00) to +100
3	Right	Right position	-100 (shown as -00) to +100
4	Bottom	Bottom position	-100 (shown as -00) to +100

When box is selected and the [MORE] button is lit amber, there are more settings. Press the [MORE] button, so that it changes from amber to green to make the extra setting.

Knob	Parameter	Adjustment	Setting values
1	Soft	Box softness	0 to 100

• When pattern is selected

Knob	Parameter	Adjustment	Setting values
1	Size	Pattern size	0 to 100
2	Soft	Edge softness	0 to 100
3	Pattern	Pattern number	1 to 24 ^{a)}

a) The pattern is the same as a standard wipe. (See the appendix “Wipe Pattern List” (Volume 2).)

Using the subsidiary mask

In the key control block, press the [SUB MASK] button, turning it on. The parameter settings depend on the mask source selected as [Wipe] or [Utility 1 Bus] in the <Mask Source> group of the Sub Mask menu for the key.

• When wipe is selected

Knob	Parameter	Adjustment	Setting values
1	Size	Pattern size	0 to 100
2	Soft	Edge softness	0 to 100

• **When utility 1 bus is selected**

Knob	Parameter	Adjustment	Setting values
1	Clip	Reference level for creating mask signal	+109 to -7
2	Gain	Gain	-100 (shown as -00) to +100

Applying a DME Effect to a Key

Assigning a DME to a key

Use the following procedure.

- 1** In the key control block, press the delegation buttons [M/E1] and [KEY1].
- 2** Using the DME channel selection buttons, select the DME channel (DME1 to DME4) for applying the effect.

The lit colors of the [DME1] to [DME4] buttons indicate the DME assignment.

Lit green: Shows the DME assigned to the currently selected key.

Lit amber: Shows the DME assigned to a key other than the currently selected key.

Off: DME is not assigned.

To select a DME being used by another keyer

Press [Override], turning it on, then select the DME channel.

The later selection is valid, and the button lights green.

Using two or three DME channels on one keyer

Use the following procedure.

- 1** Select the DME for the first channel (*see the previous item, "Assigning a DME to a key"*), then select the successive channel for the second channel. For the third channel select the channel after that.
- 2** To select the video signal for the second channel, hold down the [UTIL] button in the cross-point control block, and select the signal in the Key1 row (DME external video bus).
- 3** To select the video signal for the third channel, hold down the [UTIL] button in the cross-point control block, and carry out the following operation.



If the selected DME is channel 3 or channel 4, turn off the [KEY4] button in the key 2 row, then select the signal in the key 2 row (DME utility 1 bus).

Assigning the DME output signal to a monitor signal

Use the following procedure.

- 1** Holding down the output destination specification button [MON] in the key control block, use the DME channel selection buttons to select the DME channel (DME1 to DME8) you want to use.

The selected DME output is assigned to DME MON V and DME MON K.

- 2** To check the DME assignment status, hold down just the [MON] button.

While it is held down, the lit color of the [DME1] to [DME4] buttons shows the key assignment status.

- **Lit green:** Shows the DME currently being monitored.
- **Lit amber:** Shows a DME which can be monitored.
- **Off:** DME is not assigned.

Other Key Setting Operations

Using an external processed key

You can select and use the key processed keyer key fill and key source signals on the AUX buses.

Use the following procedure.

- 1** Select the keyer to be allocated.
- 2** In the key control block, press [PROC KEY], turning it on.

The button lights amber, and on the currently selected keyer, the key fill and key source are assigned to reentry signals PROC V and PROC K.

Note

You cannot select the PROC V and PROC K signals using the cross-point selection buttons of the M/E or PGM/PST bank.

Using a frame memory feed

When you press the FM FEED button in the key control block, it lights momentarily amber, then the key fill and key source signals processed in the currently selected keyer are assigned to frame memory sources 1 and 2.

If a DME is selected on the currently selected keyer, then the key fill and key source signals to which a DME effect is applied are assigned to frame memory sources 1 and 2.

Carrying out a frame memory feed causes the [PROC KEY] button to light amber.

Using the show key function

While the [SHOW KEY] button is held down, the key-processed key source signal appears on the specified output. (Show key mode)

Even when the [SHOW KEY] button is released, for a preset time the show key mode is maintained. You can specify the output to which the show key function is applied and set the time for which the show key mode is maintained after releasing the button in a Setup menu.

For details see “Settings Relating to Keys, Wipes and Frame Memory (Key/Wipe/FM Menu)” in Chapter 16 (Volume 2).

Using the auto delegation function

To couple the selection in the key delegation buttons of the independent key transition control block so that the key control block delegation selection is automatically switched, in the key control block press the [AUTO DELEG] button, turning it on.

Returning the key adjustment values to their defaults

Holding down a key type button ([LUM], [LIN], [CRK], [CVK], or [KEY WIPE]) recalls the key default values (*page 55*).

Key modify clear

When an M/E delegation button is held down, holding down a key delegation button together returns the key settings to the initial status settings.

For details of the initial status, see “Selecting the State After Powering On (Start Up Menu)” in Chapter 16 (Volume 2).



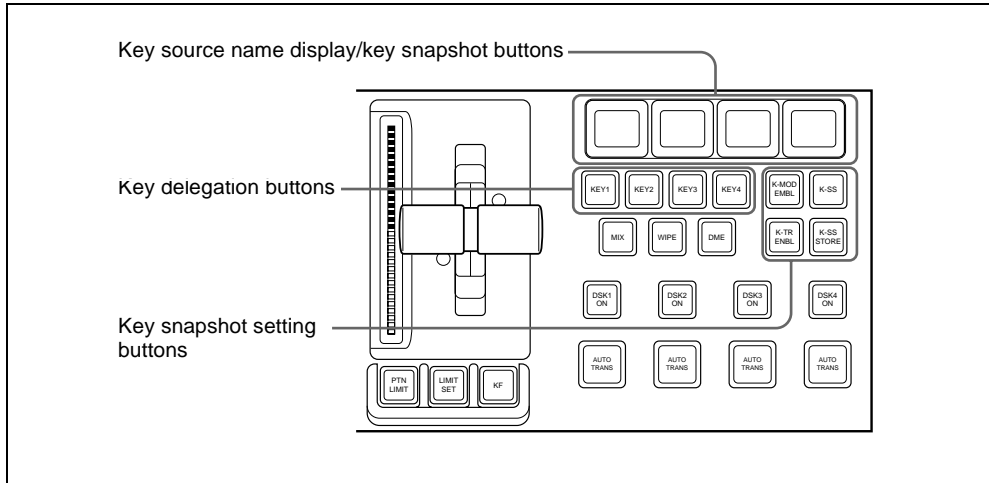
Key Snapshots

Using the key snapshot function, you can instantaneously save all of the key settings, except the key insertion state (on/off) and key priority, in dedicated registers for later recall as required.

For an overview of the key snapshots, see page 54.

Key Snapshot Operations

Key snapshot operations are carried out in the independent key transition control block or downstream key control block. Each keyer is provided with four dedicated key snapshot registers.



Independent key transition control block (standard type)

Saving a key snapshot

For example, the following procedure saves the state of the M/E-1 key 1 settings.

- 1** In the M/E-1 independent key transition control block, press the key delegation button [KEY1], turning it on.
- 2** Press the [K-SS] button, turning it on. The system switches to key snapshot mode, and the key source name display/key snapshot buttons show the status of registers 1 to 4 for key 1.

Off: Nothing is saved in the register.

Lit orange: Settings are saved in the register.

Lit yellow: The most recently recalled register.

For a register holding a snapshot, the register name is shown as up to eight characters.

- 3 Hold down the [K-SS STORE] button, and press the key source name display/key snapshot button corresponding to the register in which you want to save the snapshot.

The key source name display/key snapshot button which you pressed lights yellow.

Note

If you save a key snapshot in a register for which the button is lit orange or yellow, the existing contents of the register are overwritten.

Recalling a key snapshot

For example, the following procedure recalls the state of the M/E-1 key 1 settings.

- 1 In the M/E-1 independent key transition control block, press the key delegation button [KEY1], turning it on.
- 2 Press the [K-SS] button, turning it on.
- 3 Set the following buttons on or off, depending on the information you want to recall.
(These buttons are not provided in the downstream key control block.)

[K-MOD ENBL] button: When this is on, the key settings and key modifiers are recalled. When this is off, they are not recalled.

[K-TR ENBL] button: When this is on, the independent key transition settings are recalled. When this is off, they are not recalled.

If both buttons are off, the key memory function is enabled and only the saved selection of key fill and key source signals is recalled.

- 4 Press the key source name display/key snapshot button corresponding to the register you want to recall.

The button you pressed lights yellow, and this recalls the key snapshot.

To cancel a recall carried out in the downstream key control block, press the [UNDO] button in the downstream key control block.

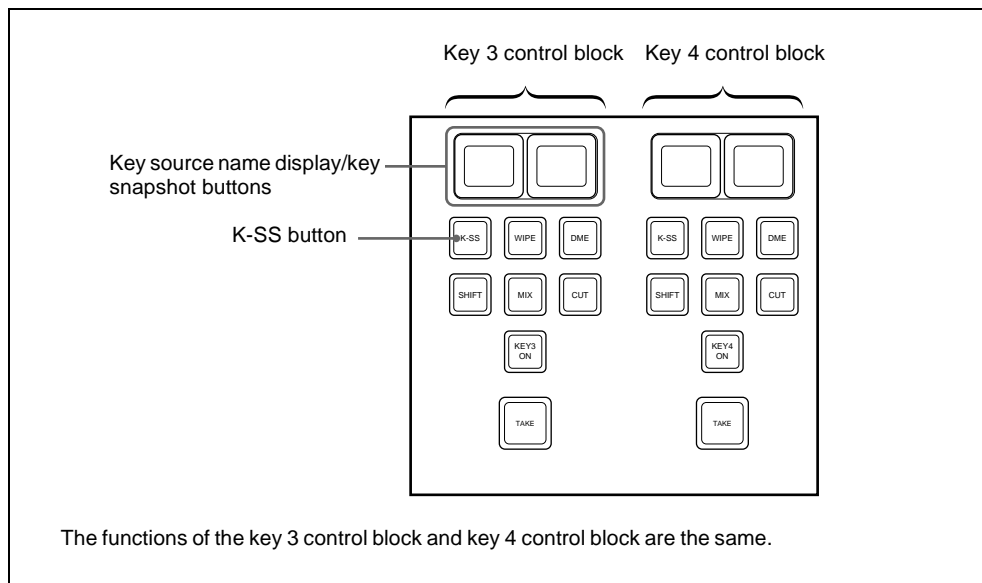


Key Snapshot Operations Using a Simple Transition Module

When using a simple transition module, the key snapshots hold the settings for key 3 and key 4.

You can carry out key snapshot operations in the independent key transition control block (simple type) and Flexi Pad control block (simple type).

There are two dedicated key snapshot registers for each of keys 3 and 4.



Independent key transition control block (simple type)

Saving a key snapshot

For example, to save the settings of M/E-1 key 3, use the following procedure.

- 1 In the M/E-1 independent key transition control block, press the [K-SS] button in the key 3 control block, turning it on.

This switches to key snapshot mode, and the key source name display/key snapshot button shows the state of registers 1 and 2 for key 3.

Off: Nothing is saved in the register.

Lit orange: Settings are saved in the register.

Lit yellow: The most recently recalled register.

For a register holding a snapshot, the register name is shown as up to eight characters.

- 2 In the Flexi Pad control block, hold down the [SNAPSHOT] button and press the key source name display/key snapshot button corresponding to the register in which you want to save the snapshot.

The key source name display/key snapshot button which you pressed lights yellow.

Note

If you save a key snapshot in a register for which the button is lit orange or yellow, the existing contents of the register are overwritten.

Recalling a key snapshot

For example, the following procedure recalls the state of the M/E-1 key 3 settings.

- 1 In the M/E-1 independent key transition control block, press the [K-SS] button in the key 3 control block, turning it on.
- 2 Press the key source name display/key snapshot button corresponding to the register you want to recall.

The button you pressed lights yellow, and this recalls the key settings (excluding the key insertion state (on/off) and key priority).



Chapter 5 Wipes

- Basic Procedure for Wipe Settings..... 304**
 - Wipe Settings Menu 304
 - Wipe Pattern Selection 304
 - Pattern Mix 307
 - Setting Wipe Modifiers 309
- Wipe Settings for Independent Key Transitions..... 322**
 - Basic Procedure for Independent Key Transition Wipe Settings .. 322
 - Setting Independent Key Transition Wipe Modifiers..... 323
- Wipe Snapshots 327**
 - Saving a Wipe Snapshot 328
 - Recalling a Wipe Snapshot..... 329
 - Deleting a Wipe Snapshot 330

Basic Procedure for Wipe Settings

You carry out wipe setting operations principally using the Wipe menu for each of the M/E-1 to M/E-3 and PGM/PST banks.

This section describes the basic procedures for wipe settings, taking the M/E-1> Wipe menu as an example.

For details of independent key transition wipe settings, see “Wipe Settings for Independent Key Transitions” (page 322).

Wipe Settings Menu

Accessing the wipe settings menu

To access the M/E-1> Wipe menu, use any of the following operations.

- In the menu control block, select the top menu selection button [M/E 1], and press VF5 ‘Wipe.’
- In the transition control block of the M/E-1 bank, press the transition type selection button [WIPE] twice in rapid succession.
- In the Flexi Pad control block of the M/E-1 bank, press the [WIPE] button twice in rapid succession.

Any of the above operations displays the M/E-1>Wipe menu.

Wipe Pattern Selection

You can select a wipe pattern in the Wipe menu, or by entering a pattern number from the Flexi Pad control block.

For how to use the Flexi Pad control block, see “Selecting a wipe pattern in the Flexi Pad control block” (page 306).

Selecting a wipe pattern by a menu operation

Use the following procedure.

- 1** In the M/E-1>Wipe menu, select HF1 ‘Main Pattern.’

The Main Pattern menu appears.

2 Select the wipe pattern group with the pattern group selection button.

- Standard:** standard wipes
- Enhanced:** enhanced wipes
- Rotary:** rotary wipes
- Mosaic1 to Mosaic3:** mosaic wipes
- Random/Dust:** random/diamond dust wipes

The patterns from the selected pattern group appear on the screen.

For details of wipe patterns, see “Types of Wipe Pattern” (page 56) and the appendix “Wipe Pattern List” (Volume 2).

3 Press the button to select the desired pattern.

4 The parameters change according to the selected pattern, and you can adjust the pattern.

- **When a polygon wipe is selected** (pattern number 49)

Knob	Parameter	Adjustment	Setting values
1	No.	Number of points	3 to 64
2	Star Rate	Angularity of star	-100.00 to +100.00 ^{a)}

a) A value of -100.00 completely removes the star “rays,” leaving a circle; at +100.00 the “rays” are at their sharpest.

- **When a mosaic wipe is selected** (pattern numbers 200 to 203, 206 to 213, 224 to 247, 250 to 257, 260 to 269)

Knob	Parameter	Adjustment	Setting values
1	H Tile No.	Number of tiles horizontally	2 to 36
2	V Tile No.	Number of tiles vertically	2 to 18

- **When a karaoke wipe is selected** (pattern numbers 220 to 223)

Knob	Parameter	Adjustment	Setting values
1	Start	Position of start tile	-100.00 to +100.00 ^{a)}
2	Row No.	Number of rows of tiles	1 to 36
3	Phase	Delay for next row	-100.00 to +100.00 ^{b)}

a) At -100.00 tiles appear from the top (or left edge) of the screen; at +100.00 from the bottom (or right edge) of the screen.

b) At -100.00 all rows appear simultaneously; at +100.00 until one row of tiles is completely displayed, the next row does not start to appear.



• **When a random wipe is selected** (pattern number 273)

Knob	Parameter	Adjustment	Setting values
1	H Size	Tile width	0.00 to 100.00
2	V Size	Tile height	0.00 to 100.00
3	Volatility	Rate of tile generation	0.00 to 100.00

• **When a diamond dust wipe is selected** (pattern number 274)

Knob	Parameter	Adjustment	Setting values
1	H Size	Particle width	0.00 to 100.00
2	V Size	Particle height	0.00 to 100.00
3	Flash Rate	Rate of generation of particles	0.00 to 100.00

Note

When Flash Rate is set to 0.00, you cannot change the pattern. In this state, adjusting H Size or V Size has no effect on the pattern.

For details of a pattern mix, see the next section.

For details of applying pattern modifiers, see “Setting Wipe Modifiers” (page 309).

Selecting a wipe pattern in the Flexi Pad control block

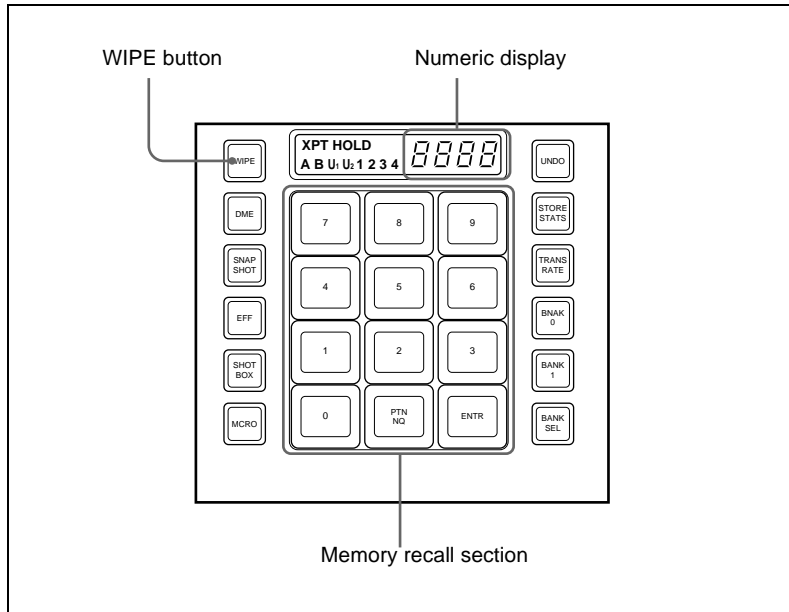
To select a pattern with a standard type Flexi Pad control block, use the following procedure. (It is not possible to select a wipe pattern with a simple type Flexi Pad control block.)

- 1** In the M/E-1 Flexi Pad control block, press the [WIPE] button.

This switches the Flexi Pad control block to wipe snapshot mode.

- 2** In the memory recall section, press the [PTN NO] button.

This switches the Flexi Pad control block to wipe pattern number recall mode, and the memory recall section display changes as shown below.



- 3** Use the buttons in the memory recall section to enter the pattern number consisting of up to three digits, and press the [ENTR] button.

The entry is confirmed, and now the numeric display shows the pattern number.

For the pattern numbers, see the appendix “Wipe Pattern List” (Volume 2).

Pattern Mix

Combining two patterns

You can combine two selected patterns (referred to as main and “sub”) to form a new pattern. Select a main pattern in the Main Pattern menu, then use the following procedure.



1 In the M/E-1>Wipe menu, select HF3 ‘Sub Pattern.’

The Sub Pattern menu appears.

2 In the same way as for the main pattern, select the sub pattern.

The patterns that can be selected for the sub pattern depend on the pattern selected for the main pattern (*see the following table*).

Possible combinations of main pattern and sub pattern

Yes: Combination possible **No:** Combination not possible

Main pattern	Sub pattern				
	Standard	Enhanced	Rotary	Mosaic	Random/diamond dust
Standard	Yes	Yes	No	Yes	Yes
Enhanced	Yes	Yes	No	Yes	Yes
Rotary	No	No	No	No	No
Mosaic	Yes	Yes	No	No	Yes
Random/diamond dust	Yes	Yes	No	Yes	No

3 Select HF2 ‘Pattern Mix.’

The Pattern Mix menu appears.

4 In the <Pattern Mix> group, select the type of pattern mix.

Mix: mix

+**Nam:** positive Nam

-**Nam:** negative Nam

Morphing: morphing

For an overview of types of pattern mix, see page 57.

5 Depending on the selection in step **4**, set the following parameters.

• **When mix, positive Nam, or negative Nam is selected**

Knob	Parameter	Adjustment	Setting values
1	Mix Ratio	Proportion of sub pattern to the main pattern	0.00 to 100.00

• **When morphing** (see page 57) is selected

Knob	Parameter	Adjustment	Setting values
2	Start	Point in transition at which main pattern is at 100%	-50.00 to +150.00
3	End	Point in transition at which sub pattern is at 100%	-50.00 to +150.00

- 6** In the <Main/Sub Link> group, make the main/sub modifier link function settings. (See “Main and sub modifier link function” (page 59).)

Full: full link mode

Semi: semi-link mode

Applying the effect of a diamond dust wipe to the selected pattern (Dust mix)

Use the following procedure.

- 1** In the Pattern Mix menu, press [Dust Mix], turning it on.
- 2** Set the following parameters as required.

Knob	Parameter	Adjustment	Setting values
1	Mix Ratio	Proportion of diamond dust pattern in mix	0.00 to 100.00
2	H Size	Particle width	0.00 to 100.00
3	V Size	Particle height	0.00 to 100.00
4	Flash Rate	Rate of generation of particles	0.00 to 100.00

You can also apply the dust mix function to the pattern generated by a pattern mix.

Note

When a rotary wipe (pattern numbers 100-107, 150, 151, 156, 158, 160, 162, 516, 518, 604, 606, 624, and 661) or random/diamond dust wipe (pattern numbers 270-274) is selected, the dust mix function is not available.

Setting Wipe Modifiers

You can apply various modifiers to the wipe pattern: setting the wipe direction, pattern position, and so on.

For an overview of the wipe modifiers, see “Wipe Pattern Variation and Modifiers” (page 59).

Note that the available modifiers may depend on the pattern you are using. For details, see “Possible combinations of wipe patterns and modifiers” (page 320).

Main pattern and sub pattern modifiers

You can make independent settings of the modifiers for the main pattern and sub pattern.

- To set the modifiers for the main pattern, in the M/E-1> Wipe menu, select HF5 ‘Main Modify,’ and make the settings in the Main Modify menu.
- To set the modifiers for the sub pattern, select HF6 ‘Sub Modify,’ and make the settings in the Sub Modify menu.

Operations in the Main Modify menu and Sub Modify menu are the same.

Independently set modifiers for the main pattern and sub pattern

- Positioner
- Rotation
- Aspect ratio
- Pattern replication (MULTI)
- Pairing
- Modulation
- Spring
- Spiral

The following sections show examples of modifying the main pattern.

Specifying the wipe direction (Direction)

You can specify the wipe direction (normal/reverse).

To specify the wipe direction in a menu

Use the following procedure.

- 1** In the M/E-1> Wipe menu, select HF4 ‘Edge/Direction.’

The Edge/Direction menu appears.

- 2** In the <Direction> group, specify the wipe direction.

Normal: regular direction

Normal/Reverse: alternate between regular and reverse for each transition

Reverse: reverse direction to normal

To specify the wipe direction with a button in the transition control block

In the transition control block of each of the M/E-1 to M/E-3 and PGM/PST banks, press the following direction selection buttons.

NORM: Normal

NORM/REV: Normal/reverse

REV: Reverse

Splitting the wipe pattern

Use the following procedure.

- 1** In the M/E-1 > Wipe menu, select HF4 ‘Edge/Direction.’
The Edge/Direction menu appears.
- 2** Press [Split], turning it on.
- 3** Set the following parameters.

Knob	Parameter	Adjustment	Setting values
1	Split No.	Number of splits	1 to 4 (integer)
2	Spacing	Spacing between adjacent patterns	0.00 to 100.00

Modifying the wipe pattern edge

Use the following procedure.

- 1** In the M/E-1 > Wipe menu, select HF4 ‘Edge/Direction.’
The Edge/Direction menu appears.
- 2** In the <Edge> group, select the edge type.
Border: border
Soft: soft edge
Soft Border: soft border
For an overview of the edge types, see “Edge” (page 60).
- 3** Set the parameters according to the selection in step **2**.
 - **When border is selected**

Knob	Parameter	Adjustment	Setting values
1	Width	Border width	0.00 to 100.00

• **When soft edge is selected**

Knob	Parameter	Adjustment	Setting values
1	Soft	Edge softness	0.00 to 100.00

• **When soft border is selected**

Knob	Parameter	Adjustment	Setting values
1	Width	Border width	0.00 to 100.00
2	Inner Soft	Border inner softness	0.00 to 100.00
3	Outer Soft	Border outer softness	0.00 to 100.00

4 When you selected border or soft border, select the edge fill signal in the <Edge Fill> group.

Utility 2 Bus: signal selected on the utility 2 bus

Matte: signal from the dedicated color matte generator

5 Depending on the operation in step 4, carry out the following operation.

When ‘Utility 2 Bus’ is selected: Hold down the [UTIL] button in the cross-point control block, and select the signal on the background B bus.

While the [UTIL] button is held down, the background B bus changes to the utility 2 bus.

Note

To enable the [UTIL] button, its operation mode must be set to [Hold] beforehand. (See “Operation Settings (Operation Menu)” in Chapter 16 (Volume 2).)

When ‘Matte’ is selected: In the same Edge/Direction menu, press [Matte Adjust] to display the Matte Adjust menu, then adjust the single-color or two-color combination color matte. Select whether to use a single-color matte or a two-color combination in the <Edge Matte> group.

Flat Color: Adjust color 1 with the following parameters.

Knob	Parameter	Adjustment	Setting values
1	Luminance	Luminance	0.00 to 100.00
2	Saturation	Saturation	0.00 to 100.00
3	Hue	Hue	359.99 to 0.00

When you select Mix Color for a two-color combination, see the next paragraph.

Carrying out a color mix for the edge fill matte

When you selected [Matte] for the border or soft border edge fill, you can combine color 1 and color 2.

For the combination, you can use not only a normal wipe generator pattern, but also the dedicated color mix pattern.

Use the following procedure.

- 1 In the <Edge Fill> group of the Edge/Direction menu, select [Matte], and press [Matte Adjust].

The Matte Adjust menu appears.

- 2 In the <Edge Matte> group, select [Mix Color], turning it on.

- 3 In the <Mix Pattern> group, make one of the following selections.

Wipe: Use the wipe pattern selected for the transition.

Pattern: Use the dedicated pattern.

- 4 Depending on the selection in step 3, set the following parameters.

• When Wipe is selected

Knob	Parameter	Adjustment	Setting values
1	Size	Pattern size	0.00 to 100.00
2	Soft	Edge softness	0.00 to 100.00

• When Pattern is selected

Knob	Parameter	Adjustment	Setting values
1	Size	Pattern size	0.00 to 100.00
2	Soft	Edge softness	0.00 to 100.00
3	Pattern	Pattern number	1 to 24 ^{a)}

a) The patterns are the same as for a standard wipe. See the appendix “Wipe Pattern List” (Volume 2).

If you selected Pattern, you can also carry out the pattern selection by pressing the [Mix Ptn Select] button in the Matte Adjust menu, to display the Mix Ptn Select menu. Select any pattern appearing in the Mix Ptn Select menu (standard wipe patterns 1 to 24) by pressing the appropriate button, and you can then adjust the following parameters.

Knob	Parameter	Adjustment	Setting values
1	Size	Pattern size	0.00 to 100.00
2	Soft	Edge softness	0.00 to 100.00



- 5** If you selected Pattern in step 4, if required, the following modifiers can be added. After selecting a wipe mix, skip to step 6.

• **When turning [Position] on and setting the pattern position**

Knob	Parameter	Adjustment	Setting values
1	Position H	Horizontal position	-200.00 to +200.00 ^{a)}
2	Position V	Vertical position	-200.00 to +200.00 ^{a)}

a) See page 61.

• **When turning [Multi] on and using replications of the same pattern**

Knob	Parameter	Adjustment	Setting values
1	H Multi	Number of repetitions of pattern horizontally	1 to 63
2	V Multi	Number of repetitions of pattern vertically	1 to 63
3	Invert Type	Replication layout	1 to 4 ^{a)}

a) See page 64.

• **When turning [Aspect] on and setting the aspect ratio of the pattern**

Knob	Parameter	Adjustment	Setting values
1	Aspect	Aspect ratio	-100.00 to +100.00 ^{a)}

a) See page 63.

• **When turning [Angle] on in the <Rotation> group and slanting the pattern**

Knob	Parameter	Adjustment	Setting values
1	Angle	Angle of pattern rotation	-100.00 to +100.00 ^{a)}

a) See page 61.

• **When turning [Speed] on in the <Rotation> group and rotating the pattern at a constant rate**

Knob	Parameter	Adjustment	Setting values
1	Speed	Rotation rate of pattern	-100.00 to +100.00 ^{a)}

a) See page 62.

- 6** To adjust color 1, set [Color1] on, and to adjust color 2 set [Color2] on, then adjust the parameters.

Knob	Parameter	Adjustment	Setting values
1	Luminance	Luminance	0.00 to 100.00
2	Saturation	Saturation	0.00 to 100.00
3	Hue	Hue	0.00 to 359.99

- 7** To interchange color 1 and color 2, press the [Color Invert] button, turning it on.

Setting the wipe position (Positioner)

You can set the position independently for the main pattern and sub pattern. Use the following procedure.

- 1** In the M/E-1> Wipe menu, select HF5 'Main Modify.'

The Main Modify menu appears.

- 2** In the <Position> group, press [Position], turning it on, and set the pattern position.

Knob	Parameter	Adjustment	Setting values
1	Position H	Horizontal position	-200.00 to +200.00 ^{a)}
2	Position V	Vertical position	-200.00 to +200.00 ^{a)}

a) See page 61.

To return the pattern position to the center of the screen

In the <Position> group, press [Center].

To move the pattern from its current position to the center through the course of a transition

In the <Position> group, press [Auto Center], turning it on.

To set the wipe position using the trackball or joystick

You can also set the wipe position using the trackball or joystick in the device control block. Use the following procedure.

- 1** In the device control block, press the [M/E1], [M/E2], [M/E3], or [P/P] button, turning it on.

The buttons in the device control block are assigned to the wipe position setting as follows.

Table 1: Buttons and assigned settings

Button name	Setting
MAIN	Wipe position for common transition (main pattern)
SUB	Wipe position for common transition (sub pattern)

Table 2: Buttons assigned to functions

Button name	Function
POS	Toggle Position on or off.
X, Y	Fix the operating direction, and enable setting of the wipe position from the numeric keypad.
CTR	Return the pattern position to the center of the screen.

- 2** Press the [MAIN] button or [SUB] button, turning it on.
- 3** Press the [POS] button, turning Position on.
- 4** Move the trackball or joystick, to set the wipe position. By pressing the [X] button, turning it on, you can restrict movement to the horizontal direction, and by pressing the [Y] button, turning it on, you can restrict movement to the vertical direction. Also, when either of these buttons is lit, you can enter a coordinate of the wipe position from the numeric keypad.

Rotating the wipe pattern (Rotation)

You can apply rotation independently to the main pattern and sub pattern. Use the following procedure.

- 1** In the M/E-1> Wipe menu, select HF5 'Main Modify.'

The Main Modify menu appears.

- 2** In the <Rotation> group, select the rotation type.

Angle: Incline the pattern through a fixed angle.

Speed: Rotate at a fixed rate.

Magnitude: Rotate through a particular angle during the course of the transition.

For an overview of the rotation, see page 61.

3 According to the selection in step **2**, set the following parameters.

• **When Angle is selected**

Knob	Parameter	Adjustment	Setting values
1	Angle	Angle of pattern rotation	-100.00 to +100.00 ^{a)}

a) See page 61.

• **When Speed is selected**

Knob	Parameter	Adjustment	Setting values
1	Speed	Rotation rate of pattern	-100.00 to +100.00 ^{a)}

a) See page 62.

• **When Magnitude is selected**

Knob	Parameter	Adjustment	Setting values
1	Angle	Angle of pattern rotation at start of transition	-100.00 to +100.00 ^{a)}
2	Magnitude	Angle of rotation through course of transition	-200.00 to +200.00 ^{a)}

a) See page 62.

Setting the wipe pattern aspect ratio (Aspect ratio)

You can set the aspect ratio independently for the main pattern and sub pattern. Use the following procedure.

1 In the M/E-1> Wipe menu, select HF5 'Main Modify.'

The Main Modify menu appears.

2 Press [Aspect], turning it on.

3 Set the following parameter.

Knob	Parameter	Adjustment	Setting values
1	Aspect	Aspect ratio	-100.00 to +100.00 ^{a)}

a) See page 63.

Setting the wipe pattern replication (Multi)

You can set pattern replication independently for the main pattern and sub pattern.

Use the following procedure.

- 1 In the M/E-1 > Wipe menu, select HF5 'Main Modify.'
The Main Modify menu appears.
- 2 Press the [Multi] button, turning it on.
- 3 Set the following parameters.

Knob	Parameter	Adjustment	Setting values
1	H Multi	Number of repetitions of pattern horizontally	1 to 63
2	V Multi	Number of repetitions of pattern vertically	1 to 63
3	Shift	Replication layout	-100.00 to +100.00 ^{a)}

a) See page 64.

- 4 To make more adjustments, press the [Multi Adjust] button.
The Multi Adjust menu appears.
- 5 Make the following settings, as required.

H Invert: When this is on, alternate tiles are inverted left-to-right.

V Invert: When this is on, alternate tiles are inverted top-to-bottom.

Non-Mask: When this is on, even if the positioner function is used to move the pattern position, the pattern is always present on the screen.

Position: By adjusting the following parameters, move the pattern position within the divisions determined in step 3.

Knob	Parameter	Adjustment	Setting values
1	Position H	Horizontal position of pattern	-200.00 to +200.00 ^{a)}
2	Position V	Vertical position of pattern	-200.00 to +200.00 ^{a)}

a) See page 61.

Making a wipe pattern like a Venetian blind (Pairing)

Use the following procedure.

- 1 In the M/E-1 > Wipe menu, select HF5 'Main Modify.'
The Main Modify menu appears.
- 2 In the <Pairing> group, select the slit direction.
H: Create slits in the horizontal direction.
V: Create slits in the vertical direction.

3 Set the following parameters.

Knob	Parameter	Adjustment	Setting values
1	Width	Width of the slits	1 to 128 (integer)
2	H Offset	Spacing in the horizontal direction	-100.00 to +100.00 ^{a)}
3	V Offset	Spacing in the vertical direction	-100.00 to +100.00 ^{a)}

a) See page 64.

Applying modulation to the wipe pattern (Modulation)

You can apply modulation independently to the main pattern and sub pattern. Use the following procedure.

1 In the M/E-1>Wipe menu, select HF5 'Main Modify.'

The Main Modify menu appears.

2 Depending on the desired effect, in the <Modulation> group select one of the following.

H: Modulate the pattern, applying waviness in the horizontal direction to edges.

V: Modulate the pattern, applying waviness in the vertical direction to edges.

Fringe: Modulate the pattern, applying waviness in the radial direction to edges.

3 Set the following parameters.

Knob	Parameter	Adjustment	Setting values
1	Amplitude	Amplitude of modulation	0.00 to 100.00
2	Frequency	Frequency of modulation	0.00 to 100.00
3	Speed	Speed of waves	-100.00 to +100.00 ^{a)}
4	Shape	Form of the modulation	1 to 3 ^{b)}

a) See page 65.

b) See page 65.

Applying barrel or pincushion distortion to the edge of the wipe pattern (Spring)

You can set the spring function independently for the main and sub patterns. Use the following procedure.

- 1 In the M/E-1 > Wipe menu, select HF5 ‘Main Modify.’
The Main Modify menu appears.
- 2 Press [Spring], turning it on.
- 3 Set the following parameters.

Knob	Parameter	Adjustment	Setting values
1	Gain	Degree of barrel distortion	-100.00 to +100.00 ^{a)}

a) See page 66.

Applying a spiral effect to the wipe pattern (Spiral)

You can set the spiral function independently for the main and sub patterns. Use the following procedure.

- 1 In the M/E-1 > Wipe menu, select HF5 ‘Main Modify.’
The Main Modify menu appears.
- 2 Press [Spiral], turning it on.
- 3 Set the following parameters.

Knob	Parameter	Adjustment	Setting values
1	Magnitude	Size and direction of the spiral	-100.00 to +100.00 ^{a)}
2	Wave Speed	Speed of the lateral waves	-100.00 to +100.00 ^{a)}

a) See page 66.

Possible combinations of wipe patterns and modifiers

Yes: Can be used **No:** Cannot be used

Modifiers	Type of wipe				
	Standard	Enhanced	Rotary	Mosaic	Random/ diamond dust
Direction	Yes	Yes	Yes	Yes	Yes
Split	Yes	Yes	No	Yes	No
Edge	Yes	Yes	Yes	Yes	Yes
Positioner	Yes ^{a)}	Yes ^{b)}	Yes ^{c)}	No	No
Rotation	Yes	Yes	Yes ^{c)}	No	No

Modifiers	Type of wipe				
	Standard	Enhanced	Rotary	Mosaic	Random/ diamond dust
Aspect ratio	Yes ^{d)}	Yes	No	No	No
Pattern replication	Yes	Yes	Yes	Yes ^{e)}	No
Pairing	Yes ^{f)}	Yes	No	No	No
Modulation (H/V)	Yes	Yes	Yes	No	No
Modulation (Fringe)	No ^{g)}	Yes	No	No	No
Spring	No ^{g)}	Yes	No	No	No
Spiral	No ^{h)}	Yes	No	No	No

- a) Not patterns 1 to 16, 19, and 20
- b) Not patterns 300 to 303
- c) Not patterns 100 to 103, 150, 151, 516, 518, 604, and 606
- d) Not patterns 1 to 8, 17, and 18
- e) Not patterns 220 to 223
- f) Not patterns 19 and 20
- g) But patterns 21, 23 and 24 are possible
- h) But patterns 21 and 23 are possible

Wipe Settings for Independent Key Transitions

You carry out independent key transition wipe setting operations using the Wipe Adjust menu for each keyer.

For an overview of independent key transitions, see page 35.

This section describes the independent key transition wipe settings, taking the M/E-1>Key1>Transition>Wipe Adjust menu as an example.

Basic Procedure for Independent Key Transition Wipe Settings

Accessing the independent key transition wipe settings menu

As an example, to access the M/E-1>Key1>Transition>Wipe Adjust menu, carry out either of the following operations.

- In the menu control block, select the top menu selection button [M/E 1] and select VF1 'Key1' and HF6 'Transition' to display the Transition menu for key 1, then press [Wipe Adjust].
- In the independent key transition control block of the M/E-1 bank, press the key delegation button [KEY1], then press the independent key transition type selection button [WIPE] twice in rapid succession.

Carrying out the above operation displays the M/E-1>Key1>Transition>Wipe Adjust menu (which will be referred to below as simply the Key1 Wipe Adjust menu).

Selecting the independent key transition wipe pattern

You select the independent key wipe pattern from the list of patterns displayed in the menu.

Note

In an independent key transition, you can only use the standard wipe patterns (pattern numbers 1 to 24).

To select a wipe pattern for independent key1 on the M/E-1 bank, use the following procedure.

- 1 In the Key1 Wipe Adjust menu, select [Pattern Select].
The Pattern Select menu appears.
- 2 Press the button for the desired pattern.

Setting Independent Key Transition Wipe Modifiers

Available modifiers

You can use the following modifiers with an independent key transition wipe. Note that the available modifiers may depend on the pattern you are using.

- Direction
- Edge
- Positioner
- Rotation
- Aspect ratio
- Pattern replication

Setting the wipe direction (Direction)

In the <Direction> group of the Key1 Wipe Adjust menu, make any of the following selections.

Normal: regular direction

Normal/Reverse: alternate between regular and reverse for each transition

Reverse: reverse direction to normal

Softening the wipe pattern edge (Soft edge)

Use the following procedure.

- 1 Press [Soft] in the Key1 Wipe Adjust menu, turning it on.
- 2 Set the following parameter.

Knob	Parameter	Adjustment	Setting values
1	Soft	Edge softness	0.00 to 100.00

Setting the wipe position (Positioner)

There are two methods of setting the wipe position: using the device control block, or in a menu.

To set the wipe position using the trackball or joystick

You can also set the wipe position using the trackball or joystick in the device control block. Use the following procedure.

- 1 In the device control block, press the [M/E1], [M/E2], [M/E3], or [P/P] button, turning it on.

The buttons in the device control block are assigned to the wipe position setting as follows.

Table 1: Buttons and assigned settings

Button name	Setting
K1 CB1	Wipe position for independent key 1 transition
K2 CB2	Wipe position for independent key 2 transition
K3 FM1	Wipe position for independent key 3 transition
K4 FM2	Wipe position for independent key 4 transition

Table 2: Buttons assigned to functions

Button name	Function
POS	Toggle Position on or off.
X, Y	Fix the operating direction, and enable setting of the wipe position from the numeric keypad.
CTR	Return the pattern position to the center of the screen.

- 2 Press one of the buttons in Table 1 above, to select the wipe position to which the operation applies. Multiple selection is possible.
- 3 Press the [POS] button, turning Position on.
- 4 Move the trackball or joystick, to set the wipe position. By pressing the [X] button, turning it on, you can restrict movement to the horizontal direction, and by pressing the [Y] button, turning it on, you can restrict movement to the vertical direction. Also, when either of these buttons is lit, you can enter a coordinate of the wipe position from the numeric keypad.

To set the wipe position by a menu operation

Use the following procedure.

- 1 Press [Position] in the Key1 Wipe Adjust menu, turning it on.

- 2** Set the following parameters.

Knob	Parameter	Adjustment	Setting values
1	Position H	Horizontal position	-200.00 to +200.00 ^{a)}
2	Position V	Vertical position	-200.00 to +200.00 ^{a)}

a) See page 61.

To move the pattern from its current position to the center through the course of a transition

Press [Auto Center] in the <Position> group, turning it on.

Rotating the wipe pattern (Rotation)

Use the following procedure.

- 1** In the <Rotation> group of the Key 1 Wipe Adjust menu, select the rotation type.

Angle: Incline the pattern through a fixed angle.

Speed: Rotate at a speed rate.

Magnitude: Rotate the pattern through a fixed angle during the course of the transition.

- 2** According to the selection in step **1**, set the following parameters.

• **When Angle is selected**

Knob	Parameter	Adjustment	Setting values
1	Angle	Angle of pattern rotation	-100.00 to +100.00 ^{a)}

a) See page 61.

• **When Speed is selected**

Knob	Parameter	Adjustment	Setting values
1	Speed	Rotation rate of pattern	-100.00 to +100.00 ^{a)}

a) See page 62.



• **When Magnitude is selected**

Knob	Parameter	Adjustment	Setting values
1	Angle	Angle of pattern rotation at start of transition	-100.00 to +100.00 ^{a)}
2	Magnitude	Angle of rotation through course of transition	-200.00 to +200.00 ^{a)}

a) See page 62.

Setting the wipe pattern aspect ratio (Aspect ratio)

Use the following procedure.

- 1** Press [Aspect] in the Key1 Wipe Adjust menu, turning it on.
- 2** Set the following parameter.

Knob	Parameter	Adjustment	Setting values
1	Aspect	Aspect ratio	-100.00 to +100.00 ^{a)}

a) See page 63.

Replicating the wipe pattern (Multi)

Use the following procedure.

- 1** Press [Multi] in the Key1 Wipe Adjust menu, turning it on.
- 2** Set the following parameters.

Knob	Parameter	Adjustment	Setting values
1	H Multi	Number of repetitions of pattern horizontally	1 to 63
2	V Multi	Number of repetitions of pattern vertically	1 to 63
3	Invert Type	Replication layout	1 to 4 ^{a)}

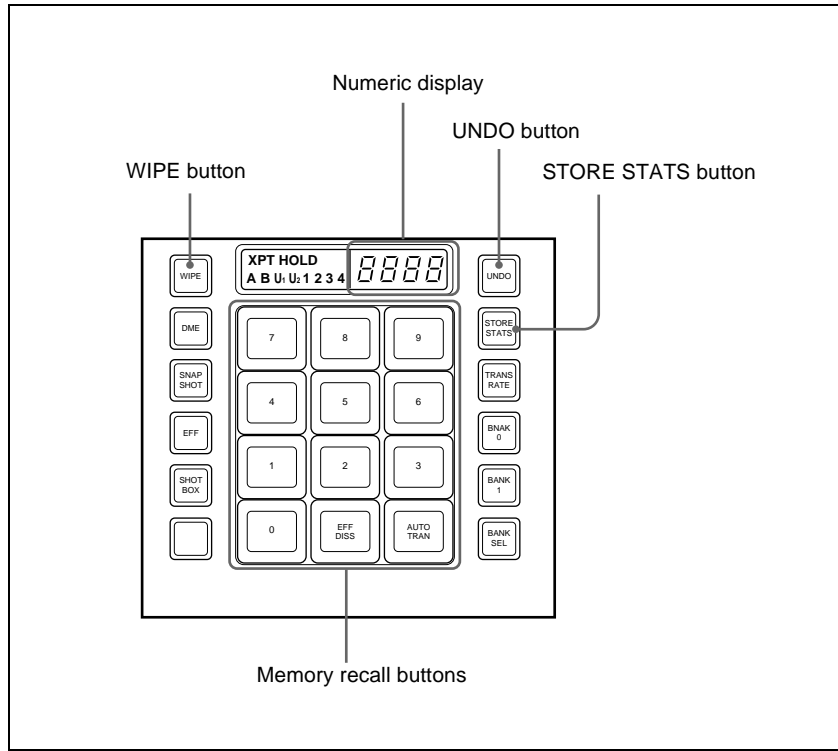
a) See page 64.

Wipe Snapshots

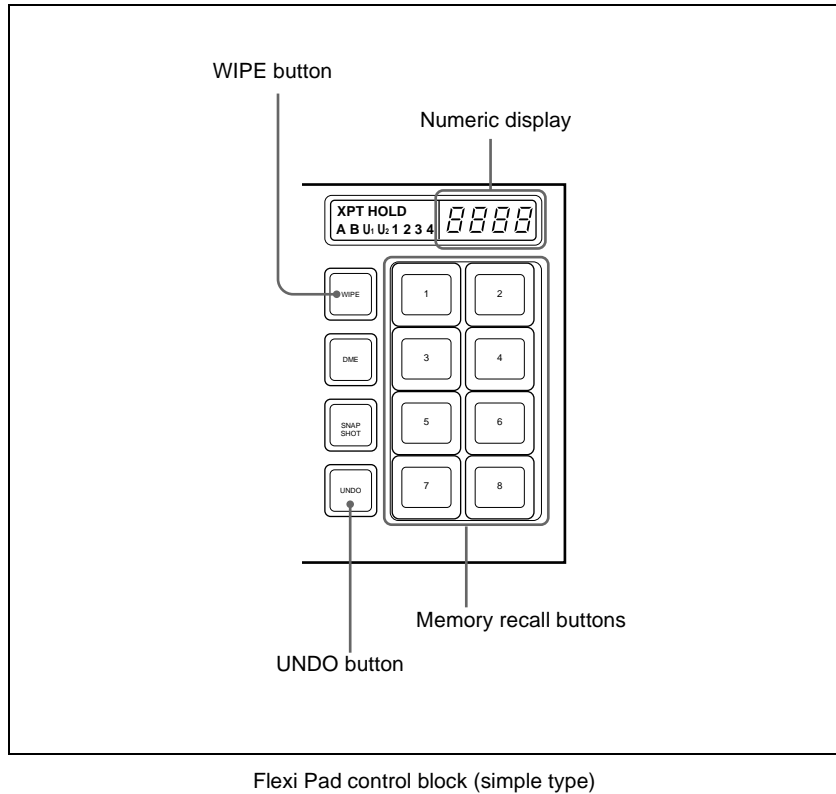
Buttons used

You can save a snapshot of a wipe pattern together with the current settings of its modifiers and the transition rate in a dedicated register, for recall when required.

In a standard transition system there are ten wipe snapshot registers for each of the M/E-1 to M/E-3 and PGM/PST banks, and in a simple transition module eight registers for each bank.



Flexi Pad control block (standard type)



Saving a Wipe Snapshot

Saving a wipe snapshot

Use the following procedure.

- 1** Make the wipe settings that you want to save.
- 2** In the Flexi Pad control block, hold down the [WIPE] button, and press the memory recall button corresponding to the register in which you want to save.

Notes

- If you press a button which is lit orange or yellow, the existing contents of the register are overwritten.
- If you carry out a pattern mix, and both the main pattern and sub pattern are selected, then the memory recall button shows the main pattern.

The pattern appears on the button you pressed, which lights yellow. The numeric display shows the number of the corresponding pattern. It is also possible to display the register name using a Setup menu (*see “Operation Settings (Operation Menu)” in Chapter 16 (Volume 2)*).

Meaning of the state of buttons

Off: Nothing is saved in the register.

Lit orange: Settings are saved in the register.

Lit yellow: The most recently recalled register.

Canceling the saving of a wipe snapshot

To cancel the saving of a wipe snapshot immediately after performing it, hold down the [STORE STATS] button, and press the [UNDO] button. The [STORE STATS] button changes from amber to green.

Note

On a simple type Flexi Pad control block, it is not possible to cancel the saving of a wipe snapshot.

Recalling a Wipe Snapshot

Recalling a wipe snapshot

Use the following procedure.

- 1** In the Flexi Pad control block, press the [WIPE] button.

This switches the Flexi Pad control block to the mode for recalling a wipe snapshot.

- 2** Press the memory recall button for the register from which you want to recall the wipe snapshot.

The button lights, and the saved wipe snapshot is recalled. At this point, the numeric display shows the pattern number or register name.

Canceling the recall of a wipe snapshot

To cancel the recall of a wipe snapshot, press the [UNDO] button.

Deleting a Wipe Snapshot

Deleting a wipe snapshot

When the [WIPE] button is lit in the Flexi Pad control block, hold down the [STORE STATS] button and press the memory recall button for the register in which you want to delete the wipe snapshot.

The indication of the memory recall button reverts from the wipe pattern or register name to the register number.

Note

In a simple type Flexi Pad control block, it is not possible to delete a wipe snapshot.



Chapter 6 DME Wipes

- Basic Procedure for DME Wipe Settings 332**
 - DME Wipe Settings Menu 332
 - DME Wipe Pattern Selection 332
 - Setting DME Wipe Modifiers..... 333
- DME Wipe Settings for Independent Key Transitions 339**
 - Basic Procedure for Independent Key Transition DME Wipe Settings
339
 - Setting Independent Key Transition DME Wipe Modifiers..... 340
- DME Wipe Snapshots..... 341**
- Creating User Programmable DME Patterns..... 342**
 - User Programmable DME Transition Mode 342

Basic Procedure for DME Wipe Settings

You carry out DME wipe setting operations principally using the DME Wipe menu for each of the M/E-1 to M/E-3 and PGM/PST banks.

This section describes the basic procedures for DME wipe settings, taking the M/E-1>DME Wipe menu as an example.

For details of independent key transition DME wipe settings, see “DME Wipe Settings for Independent Key Transitions” (page 339).

Note

To carry out DME wipes requires the BKDS-9470 DME Board Set.

DME Wipe Settings Menu

Accessing the DME Wipe menu

To access the M/E-1>DME Wipe menu, use any of the following operations.

- In the menu control block, select the top menu selection button [M/E 1], and press VF6 ‘DME Wipe.’
- In the transition control block of the M/E-1 bank, press the transition type selection button [DME] twice in rapid succession.
- In the Flexi Pad control block of the M/E-1 bank, press the [DME] button twice in rapid succession.

Any of the above operations displays the M/E-1>DME Wipe menu.

DME Wipe Pattern Selection

You can select a DME wipe pattern in the DME Wipe menu, or by entering a pattern number from the Flexi Pad control block.

Selecting a DME wipe pattern by a menu operation

Use the following procedure.

- 1** In the M/E-1>DME Wipe menu, select HF1 ‘1ch’ for one-channel mode or HF2 ‘2ch’ for two-channel mode.

- 2 Select the desired DME wipe pattern group with one of the following buttons.

Slide/Squeeze: slide and squeeze

Split/Door: split and door

Flip/Tumble: flip tumble

Page Turn/Roll: page turn and page roll

Frame I/O: frame in/out

P In P: picture-in-picture

User Program: user programmable DME

In two-channel mode, only Slide/Squeeze, P In P and User Program are selectable.

For details of DME wipe patterns, see “Types of DME Wipe Pattern” (page 68) and the appendix “DME Wipe Pattern List” (Volume 2).

The patterns from the selected pattern group appear on the screen.

- 3 Press the button to select the desired pattern.

Note

For a key transition, the page turn, page roll and picture-in-picture cannot be used.

Selecting a DME wipe pattern in the Flexi Pad control block

In the standard type Flexi Pad control block, enter a 4-digit pattern number, using the [DME] button.

For details, see “Selecting a wipe pattern in the Flexi Pad control block” (page 306).

Note

You cannot select a DME wipe pattern in the simple type Flexi Pad control block.

Setting DME Wipe Modifiers

You can apply various modifiers to the DME wipe pattern: setting the DME wipe direction, pattern position, and so on.

For an overview of the DME wipe modifiers, see “DME Wipe Pattern Variation and Modifiers” (page 70).

Specifying the DME wipe direction (Direction)

You can specify the DME wipe direction (normal/reverse).

To specify the DME wipe direction in a menu

Use the following procedure.

- 1 In the M/E-1>DME Wipe menu, select HF4 'Edge/Direction.'

The Edge/Direction menu appears.

- 2 In the <Direction>group, specify the DME wipe direction.

Normal: regular direction

Normal/Reverse: alternate between regular and reverse for each transition

Reverse: reverse direction to normal

To specify the DME wipe direction with a button in the transition control block

In the transition control block of each of the M/E-1 to M/E-3 and PGM/PST banks, press the following direction selection buttons.

NORM: Normal

NORM/REV: Normal/reverse

REV: Reverse

Modifying the DME wipe pattern edge

Use the following procedure.

- 1 In the M/E-1>DME Wipe menu, select HF4 'Edge/Direction.'

The Edge/Direction menu appears.

- 2 Depending on whether the selected pattern is in one-channel mode or two-channel mode, proceed as follows.

For a pattern in one-channel mode: press [1st Ch], turning it on.

For a pattern in two-channel mode: from the <Ch Select> group, select the corresponding channel. You can select more than one channel at the same time.

- 3 In the <Edge> group, select the edge type.

Border: border

Soft Border: soft border

- 4** Set the parameters according to the selection in step 3.

• **When border is selected**

Knob	Parameter	Adjustment	Setting values
1	Width	Border width	0.00 to 100.00
3	Luminance	Luminance	0.00 to 100.00
4	Saturation	Saturation	0.00 to 100.00
5	Hue	Hue	359.99 to 0.00

• **When soft border is selected**

Knob	Parameter	Adjustment	Setting values
1	Width	Border width	0.00 to 100.00
2	Inner Soft	Border inner softness	0.00 to 100.00
3	Luminance	Luminance	0.00 to 100.00
4	Saturation	Saturation	0.00 to 100.00
5	Hue	Hue	359.99 to 0.00

Display indications when multiple channels are selected at the same time

The indications on the knobs show the settings of the lowest-numbered channel. When you turn the knobs to adjust the settings, this changes the settings on the other channels by the same amount.

Setting the DME wipe position (Positioner)

Use the following procedure.

- 1** In the M/E-1>DME Wipe menu, select HF5 'Modify.'

The Modify menu appears.

- 2** Depending on whether the DME wipe pattern is in one-channel mode or two-channel mode, proceed as follows.

For a pattern in one-channel mode: press [1st Ch], turning it on.

For a pattern in two-channel mode: from the <Ch Select> group, select the corresponding channel. You can select more than one channel at the same time.

3 In the <Position> group, press [Position], turning it on.

4 Set the following parameters.

Knob	Parameter	Adjustment	Setting values
1	H	Horizontal position	-200.00 to +200.00
2	V	Vertical position	-200.00 to +200.00

Display indications when multiple channels are selected at the same time

The indications on the knobs show the settings of the lowest-numbered channel. When you turn the knobs to adjust the settings, this changes the settings on the other channels by the same amount.

To return the DME wipe pattern position to the center of the screen
In the <Position> group, press [Center].

Displaying and moving the position of the DME wipe pattern (position select)

Use the following procedure.

1 In the M/E-1>DME Wipe menu, select HF5 ‘Modify.’

The Modify menu appears.

In the <Position Select> group, the one of the [Top Left], [Top Right], [Bottom Left], and [Bottom Right] buttons that is on indicates the current display position of the DME wipe pattern.

2 In the <Position> group, press [Position], turning it on.

3 Depending on whether the DME wipe pattern is in one-channel mode or two-channel mode, proceed as follows.

In one-channel mode: press [1st Ch], turning it on.

In two-channel mode: from the <Ch Select> group, select the corresponding channel. You can select more than one channel at the same time.

4 To move the position of the DME wipe pattern, press the button where you want to move to, turning it on.

The DME wipe pattern displayed on the screen moves to the position of the specified button.



Setting the DME wipe pattern size (Size)

Use the following procedure.

- 1** In the M/E-1>DME Wipe menu, select HF5 ‘Modify.’
The Modify menu appears.
- 2** Depending on whether the selected pattern is in one-channel mode or two-channel mode, proceed as follows.
For a pattern in one-channel mode: press [1st Ch], turning it on.
For a pattern in two-channel mode: from the <Ch Select> group, select the corresponding channel. You can select more than one channel at the same time.
- 3** Press [Size], turning it on.
- 4** Set the following parameters.

Knob	Parameter	Adjustment	Setting values
1	Size	Set size of effect	0.00 to 200.00 ^{a)}

a) The current effect size of the DME wipe pattern is taken as 100.00%.

Display indications when multiple channels are selected at the same time

The indications on the knobs show the settings of the lowest-numbered channel. When you turn the knobs to adjust the settings, this changes the settings on the other channels by the same amount.

Adjusting the DME wipe pattern cropping

Use the following procedure.

- 1** In the M/E-1>DME Wipe menu, select HF5 ‘Modify.’
The Modify menu appears.
- 2** Depending on whether the selected pattern is in one-channel mode or two-channel mode, proceed as follows.
For a pattern in one-channel mode: press [1st Ch], turning it on.
For a pattern in two-channel mode: from the <Ch Select> group, select the corresponding channel. You can select more than one channel at the same time.

3 In the <Crop Mode> group, press [Crop], turning it on.

4 Set the following parameters.

Knob	Parameter	Adjustment	Setting values
1	Top	Crop the top of the image	-100.00 to +100.00
2	Left	Crop the left of the image	-100.00 to +100.00
3	Right	Crop the right of the image	-100.00 to +100.00
4	Bottom	Crop the bottom of the image	-100.00 to +100.00

Display indications when multiple channels are selected at the same time

The indications on the knobs show the settings of the lowest-numbered channel. When you turn the knobs to adjust the settings, this changes the settings on the other channels by the same amount.

In 16:9 mode, to crop to 4:3 aspect ratio

In the <Crop Mode> group, press [4:3], turning it on.



DME Wipe Settings for Independent Key Transitions

You carry out independent key transition DME wipe setting operations using the DME Wipe Adjust menu for each keyer.

For an overview of independent key transitions, see page 35.

This section describes the independent key transition DME wipe settings, taking the M/E-1>Key1>Transition>DME Wipe Adjust menu as an example.

Basic Procedure for Independent Key Transition DME Wipe Settings

Accessing the independent key transition DME wipe settings menu

As an example, to access the M/E-1>Key1>Transition>DME Wipe Adjust menu, carry out the following operation.

- In the menu control block, select the top menu selection button [M/E 1], and select VF1 'Key1' and HF6 'Transition' to display the Transition menu for key 1. Next, press [DME Wipe Adjust].

Carrying out the above operation displays the M/E-1>Key1>Transition>DME Wipe Adjust menu (which will be referred to below as simply the Key1 DME Wipe Adjust menu).

Selecting the independent key transition DME wipe pattern

You select the independent key DME wipe pattern from the list of patterns displayed in the menu.

Note

For an independent key transition, only the slide, split, squeeze, door, frame in/out, and user programmable DME patterns are available.

To select a DME wipe pattern for independent key 1 on the M/E-1 bank, use the following procedure.

- 1 In the <Pattern Select> group of the Key1 DME Wipe Adjust menu, press [1ch].
The Pattern Select menu for one-channel mode appears.
- 2 Select the desired DME wipe pattern group with one of the following buttons.
Slide/Squeeze: slide and squeeze
Split/Door: split and door
Frame I/O: frame in/out
User Program: user programmable DME
For details of DME wipe patterns, see “Types of DME Wipe Pattern” (page 68) and the appendix “DME Wipe Pattern List” (Volume 2).
The patterns from the selected pattern group appear on the screen.
- 3 Press the button to select the desired pattern.

Setting Independent Key Transition DME Wipe Modifiers

You can set the pattern position for an independent key transition DME wipe.
For an overview of this function, see “Positioner” (page 61).

Setting the DME wipe position (Positioner)

Use the following procedure.

- 1 In the <Position> group of the Key1 DME Wipe Adjust menu, press [Position], turning it on.
- 2 Set the following parameters.

Knob	Parameter	Adjustment	Setting values
1	H	Horizontal position	-200.00 to +200.00
2	V	Vertical position	-200.00 to +200.00

To return the DME wipe pattern position to the center of the screen
In the <Position> group, press [Center].

DME Wipe Snapshots

To carry out DME wipe snapshot operations, use the Flexi Pad control block. You can save, recall and delete DME wipe snapshots using the procedures similar to the procedures for wipe snapshot operations. In DME wipe snapshot operations, use the [DME] button instead of the [WIPE] button used in wipe snapshot operations.

Note

In a simple type Flexi Pad control block, it is not possible to delete a DME wipe snapshot.

For details of the operating procedures, see “Wipe Snapshots” (page 327).



Creating User Programmable DME Patterns

With a user programmable DME, you can use DME effects created through the use of keyframes for a transition on the switcher system.

Note the following points when creating a keyframe effect for use as a user programmable DME pattern.

Register numbers and pattern numbers

When saving a keyframe effect as a user programmable DME pattern, specify the register number that corresponds to the pattern number as shown in the following table.

Execution mode	Register number	Pattern number
One-channel mode	101 to 199	1901 to 1999
Two-channel mode	201 to 299	2901 to 2999

For details of registers and keyframe effects, see “Registers” (page 125) and Chapter 13 “Keyframe Effects” (Volume 2), respectively.

Keyframe effects in the global channel

When the effect with the same number as the reference channel is present on the DME global (GLBL) channel, executing the user programmable DME will also execute the effect on the global channel simultaneously.

When executing a user programmable DME, take note of whether the effect is present on the global channel.

User Programmable DME Transition Mode

To create a user programmable DME, it is necessary to set the transition mode (the way in which the effect moves). To set the transition mode, use the Key Frame>DME User PGM menu.

The following transition modes are available.

Channel	Transition mode	Effect group
One-channel mode	Single transition mode	Slide
		Squeeze
		Split
		Door
		Page turn
		Page roll
	Dual transition mode	Flip tumble
Two-channel mode	Frame in-out	Frame in-out
	Picture-in-picture	Picture-in-picture
	Dual transition mode	Slide
		Squeeze
	Picture-in-picture	Picture-in-picture

Notes on creating keyframe effects

When creating a keyframe effect to be used as a user programmable DME pattern, note the following, depending on the transition mode used.

Notes on single transition mode (one-channel mode)

- Either create the first keyframe image outside the screen area, or set the image size to zero so that it cannot be seen within the screen.
- Create the last keyframe to be a full-size image.
- In the <Transition Mode> group of the Key Frame>DME User PGM menu, select [Single].

Notes on dual transition mode (one-channel mode)

- Create the first keyframe to be a full-size image. In the DME>Input/Output>Video/Key menu, press [Separate Side], turning it on. Then, in the <Back> group of the same menu, press [H Invert] or [V Invert], turning it on, depending on the direction in which you want to rotate the image during the transition.
- Create the last keyframe so that the image is reversed and the back side is visible, and with the image size remaining at full-size.
- In the <Transition Mode> group of the Key Frame> DME User PGM menu, select [Dual].

Notes on frame in-out (one-channel mode)

Create a minimum of three keyframes.

- Either create the first keyframe image outside the screen area, or set the image size to zero so that it cannot be seen within the screen.



- Create the first transition to end such that the image can be seen within the screen. At this point, press the [PAUSE] button in the keyframe control block, turning it on, to set a pause for the keyframe.
- Either create the last keyframe image outside the screen area, or set the image size to zero so that it cannot be seen within the screen.
- In the <Transition Mode> group of the Key Frame>DME User PGM menu, select [FRAME I/O].

Notes on picture-in-picture (one-channel mode)

Create a minimum of three keyframes.

- Create the first keyframe with the image full-size.
- Create the first transition to end such that the image can be seen within the screen. At this point, press the [PAUSE] button in the keyframe control block, turning it on, to set a pause for the keyframe.
- Create the last keyframe again with the image full-size.
- In the <Transition Mode> group of the Key Frame>DME User PGM menu, select [P In P].

Notes on dual transition mode (two-channel mode)

- Create the first keyframe for each channel as follows.
Channel 1: create the image full-size.
Channel 2: either create the image outside the screen area, or set the image size to zero so that it cannot be seen within the screen.
- Create the last keyframe for each channel as follows.
Channel 1: either create the image outside the screen area, or set the image size to zero so that it cannot be seen within the screen.
Channel 2: create the image full-size.
- In the <Transition Mode> group of the Key Frame>DME User PGM menu, select [Dual].

Notes on picture-in-picture (two-channel mode)

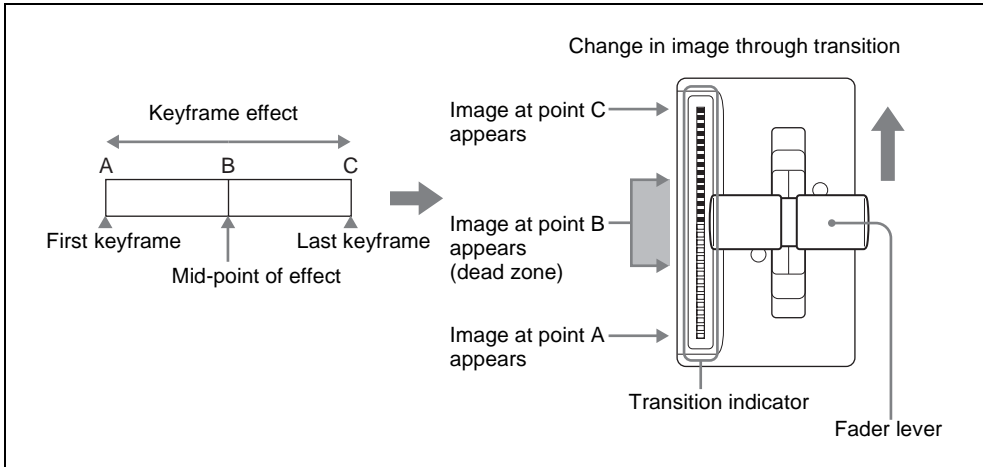
Create a minimum of three keyframes.

- Create the first keyframe for each channel as follows.
Channel 1: create the image full-size.
Channel 2: since the priority is low, it will not be visible on the screen, so no particular restrictions apply.
In the Global Effect>Ch1 to Ch4>Combiner menu, when setting the priority of channel 1 and channel 2, set the channel 1 priority higher.
- In the intermediate part of the transition, create the two images so that both are visible within the screen. In the Global Effect>Ch1 to Ch4>Combiner menu, when setting the priority of channel 1 and channel 2, set the channel 2 priority higher.

Note

It is recommended to make the priority settings at a keyframe point at which the two images are not overlapping.

- During the course of a transition, there is a “dead zone” corresponding to the intermediate point of the whole effect (*see following figure*), during which the image does not change. Therefore, it is necessary to create the effect so that the image in the intermediate part of the transition is the keyframe for the mid-point of the whole effect. The range of this “dead zone” corresponds to the central one-third of the range of the transition indicator. This also applies to an auto transition.



- Create the last keyframe for each channel as follows.
 - Channel 1:** since the priority is low, it will not be visible on the screen, so no particular restrictions apply.
 - Channel 2:** create the image full-size.
- In the <Transition Mode> group of the Key Frame>DME User PGM menu, select [P In P].



Chapter 7 Frame Memory

Frame Memory Operations	348
Preparations	348
Interpreting the Frame Memory Menu	348
Selecting an Input Image	350
Selecting Outputs and Target Frame Memory	351
Capturing an Image (Freeze)	352
Recalling Images	354
Image Processing	356
Image Output	360
Image Data Management	362
Deleting Files	362
Renaming Files	363
Restoring Files	364

Frame Memory Operations

For an overview of frame memory concepts, see “Frame Memory” (page 73).

Preparations

Allocating the frame memory outputs (FM1 to FM8) to cross-point buttons

To output a frame memory image to a monitor, for example, the output signal from the frame memory (FM1 to FM8) must be allocated to a cross-point button. Carry out this allocation in the Setup menu.

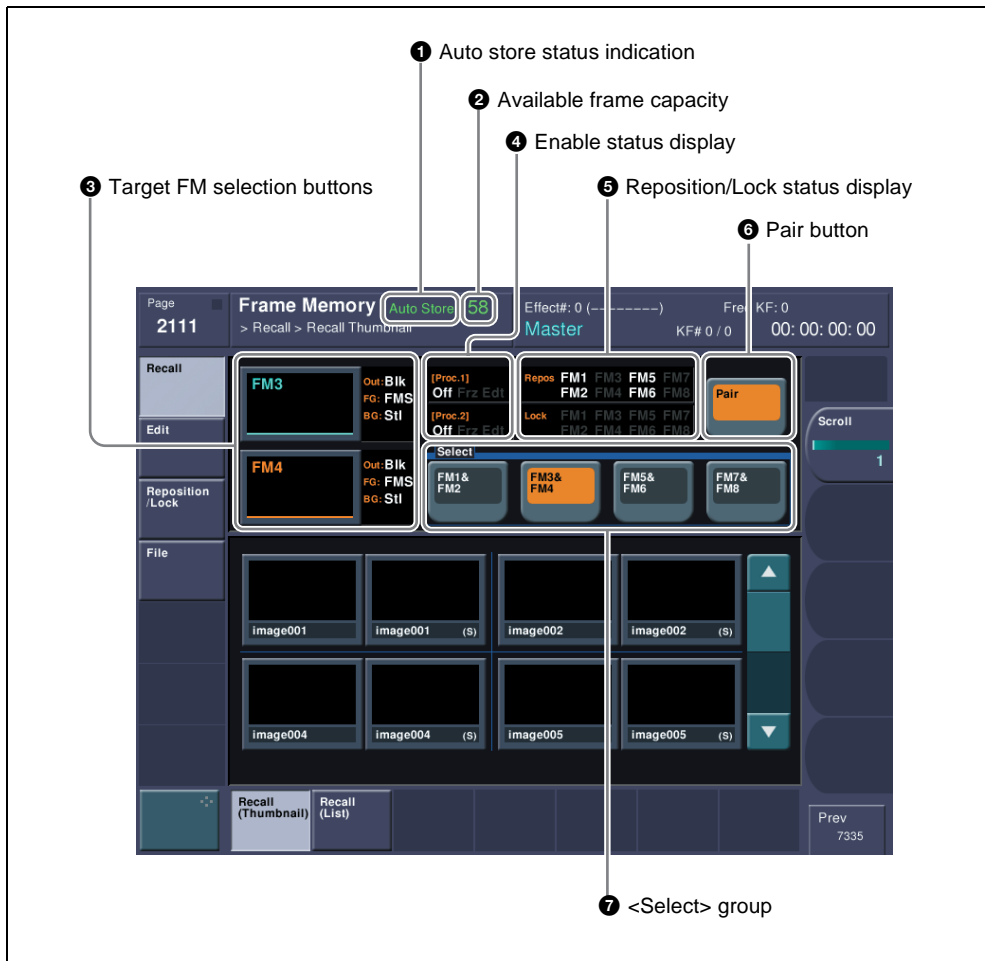
Accessing the Frame Memory menu

Most frame memory operations are carried out using the Frame Memory menu. To access the Frame Memory menu, use either of the following procedures.

- In the menu control block, select the top menu selection button [FRAME MEM].
- Press the cross-point button to which the frame memory output is allocated twice in rapid succession.

Interpreting the Frame Memory Menu

The menu screen consists of the following principal parts.
The status area display is the same for all except the Pattern Adjust/Pattern Select/File menus.



Frame Memory menu

1 Auto store status indication

This appears when the auto store function has been enabled in setup.

2 Available frame capacity

This shows the remaining number of frames that can be stored. When there is no remaining space the number (1 in pair mode, and 0 in single mode) is shown in red.

3 Target FM selection buttons

These select which of the selected outputs the operation applies to. When manipulating a saved image, the file name appears.

To the right of the button is shown the current frame memory output signal, input signal, and processing background signal status.

<Out>: output signal status

Blk: when black signal is output
Thr: when input image is output
Frz: when a freeze is output
Fil: when still image file is output
Com: when image is processed

<FG>: input signal status

FMS: frame memory source
Col: color matte signal

<BG>: processing background signal status

Blk: black signal
Stl: still image (freeze image or still image file)

4 Enable status display

Off: Both Freeze Enable and Edit Enable are off.

Frz: Freeze Enable is on.

Edt: Edit Enable is on.

5 Reposition/Lock status display

These appear for frame memory outputs (FM1 to FM8) when reposition (*see page 360*) or lock (*see page 361*) is currently applied.

6 Pair button

Press this button, turning it on, to enable pair mode.

7 <Select> group

Select the output to which operations apply.

Selecting an Input Image

For the input image to frame memory, you can use either the signal selected on one of the two frame memory source buses or a dedicated color matte signal. When using the signal on frame memory source bus 1 or 2 for the input image, select the signal as described below.

For the method of using a color matte signal, see “Freezing an image and writing it to memory” (page 352).

Selecting the signal on a frame memory source bus

As an example, to select a signal on frame memory source bus 1, use the following procedure.

- 1** In the auxiliary bus control block, press the AUX delegation button to which frame memory source bus 1 is allocated, turning it on.

For allocation of buses to the AUX delegation buttons, see “AUX Delegation Buttons Settings (Aux Assign Menu)” in Chapter 16 (Volume 2).

- 2** In the auxiliary bus control block cross-point buttons, select the signal to be used for the input image.

To select a signal with a key or DME effect applied on the frame memory source bus

In the key control block, press the [FM FEED] button, turning it on.

This automatically assigns the key fill and key source signals being keyed by the currently selected keyer to frame memory source buses 1 and 2.

When DME is selected on the keyer, the key fill and key source signals to which a DME effect is applied are assigned.

Selecting Outputs and Target Frame Memory

Selecting outputs (FM) and target frame memory

The signals of frame memory source buses 1 and 2 are used assigned to one of the pairs of FM1&2, FM3& 4, FM5&6, and FM7&8. The following description applies to the case of assignment to FM1&2, but the procedures are similar for the other cases.

- 1** In the Frame Memory menu, press one of VF1 to VF3, and select the required HF menu.

The current status of frame memory appears in the status area. (*See page 349.*)

- 2** If required, press [Pair], to select the FM operation mode (pair mode).

On: Operate on FM1(3, 5, 7) and FM2(4, 6, 8) as a pair.

Off: Operate on FM1(3, 5, 7) and FM2(4, 6, 8) individually.

For more details, see “Pair mode” (page 73).

- 3** In the <Select> group, press [FM1 & FM2] to select it.

This assigns the signals to FM1 and FM2.

To the right of the target FM selection buttons (*see page 349*), the FM output status appears.

- 4 If in step 2 you set [Pair] to be off, press the target FM selection button [FM1] or [FM2] (*see page 349*) to select the FM operations apply to.

When [Pair] is on, whichever of FM1 and FM2 you press, the pair is selected. When off, it is necessary to select which the operations apply to.

Capturing an Image (Freeze)

Freezing an image and writing it to memory

To freeze the signal selected as input material, and write it to memory, use the following procedure.

- 1 In the Frame Memory menu, select VF2 'Edit' and HF1 'Freeze.'

The Freeze menu appears.

- 2 Select the target frame memory.

For the procedure, see "Selecting outputs (FM) and target frame memory" (page 351).

- 3 To enable V/K mode, press [V/K Mode] turning it on.

- 4 Press [Freeze Enable], turning it on.

A freeze is now possible.

- 5 If necessary, make the video process settings (*see page 353*) or mask settings (*see page 354*) for application to the selected signal.

- 6 In the state in which you want to freeze, press one of the following in the <Freeze> group, to write the freeze image to temporary memory.

Frame: Freeze one frame.

Field: Freeze one field.

Off: Release the freeze, and delete the recorded freeze image.

After carrying out the freeze, to return to the state immediately before the freeze, press [Undo] in the <Freeze> group.

Notes

- All freeze images written to temporary memory are lost when the system is powered off.
- If you change the frame memory to use as in step 2 before saving the freeze images written to temporary memory, all the freeze images in



temporary memory are lost, unless the auto store function has been enabled in setup. With the auto store function enabled, the freeze images written to temporary memory are saved automatically when the frame memory selection is changed.

Saving a freeze image

To save a captured freeze image in a file, use the following procedure in the Edit>Freeze menu.

1 Press [Store].

The keyboard window (*see page 220*) appears.

The default file name, “image###” (where ### is a three-digit number) is input.

2 In the keyboard window, enter the file name (maximum 8 characters).

3 In the keyboard window, press the [Enter] button.

This saves the freeze image as a file in memory.

Note

When the system is powered off, the file saved in memory is erased, but you can restore it in the Frame Memory menu. (*See “Restoring Files” (page 364).*)

Setting video processing

To set video processing for the signal selected on a frame memory source bus, use the following procedure in the Edit>Freeze menu.

1 In the <Video Process> group, press [Video Process], turning it on.

2 Use the knobs to adjust the following parameters.

Knob	Parameter	Adjustment	Setting values
1	Video Gain	Overall gain of the video signal	-200.00 to +200.00
2	Y Gain	Y signal gain	-200.00 to +200.00
3	C Gain	Chrominance signal gain	-200.00 to +200.00
4	Hue Delay	Hue delay	-180.00 to +180.00
5	Black Level	Y signal black level	-7.30 to +109.58

To return the settings to the default values, press [Unity] in the <Video Process> group.

Note

When a pair setting is active, it is coupled to the video process on/off setting, but the above parameter settings are only valid for frame memory source bus 1. When setting video process for frame memory source bus 2, disable the pair setting. To set video process for frame memory source bus 1 only with the pair setting, return the frame memory source bus 2 settings to their default values.

Setting a mask

Masks can be set separately for frame memory source buses 1 and 2. To apply a mask to the signal selected on frame memory source bus 1, for example, use the following procedure in the Edit>Freeze menu.

- 1 Press [Box Mask] turning it on.
- 2 Use the knobs to adjust the following parameters.

Knob	Parameter	Adjustment	Setting values
1	Top	Top position	-100.00 to +100.00
2	Left	Left position	-100.00 to +100.00
3	Right	Right position	-100.00 to +100.00
4	Bottom	Bottom position	-100.00 to +100.00

- 3 To link the masks on frame memory source buses 1 and 2, press [Mask Link], turning it on.

Recalling Images

Using the thumbnail display to recall an image

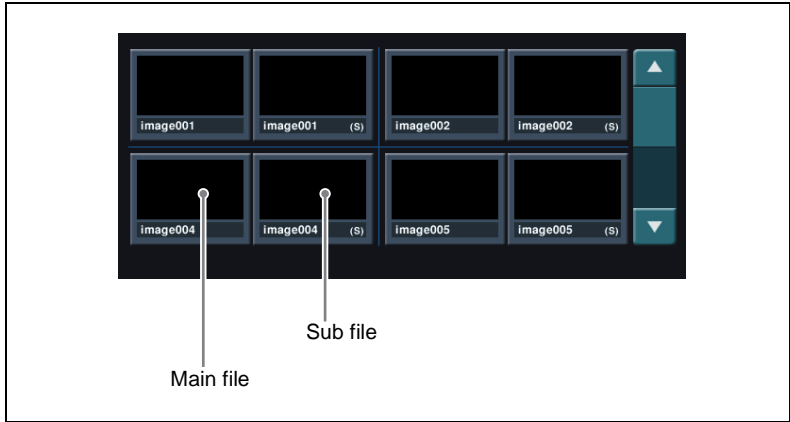
To recall an image file saved in memory using the thumbnails, and assign it to an FM output, use the following procedure.

- 1 In the Frame Memory menu, select VF1 'Recall' and HF1 'Recall Thumbnail.'

The Recall Thumbnail menu appears.

- When [Pair] is on, only pair files (pairs of main file and sub file) are displayed.





- When [Pair] is off, both single files and pair files appear.



- 2 In the status area, select the FM to be assigned. (See page 351.)
- 3 Using the arrow keys or turning the knob, scroll the file thumbnail display.

Knob	Parameter	Adjustment	Setting values
1	Scroll	Scroll thumbnails	1 to ...

- 4 Press the thumbnail of the image you want to recall.

This recalls the image file, which is assigned to the FM you selected in step 2.

Using the list display to recall an image

To recall an image file saved in memory using the list display, and assign it to an FM output, use the following procedure.

- 1** In the Frame Memory menu, select VF1 'Recall' and HF2 'Recall List.'
The Recall List menu appears.
- 2** In the status area, select the FM to be assigned. (*See page 351.*)
- 3** Using any of the following methods, select the file to be recalled. The main and sub files scroll simultaneously.
 - Press directly on the list to select.
 - Press the arrow keys to scroll the reverse video cursor.
 - Turn the knob to make the selection.

Knob	Parameter	Adjustment	Setting values
1	No	Memory file selection	1 to ...

- 4** To recall the main file in the selected list, press [Main] in the <Recall> group. Similarly, to recall the sub file, press [Sub].

This recalls the image file, which is assigned to the FM you selected in step **2**.

When pair mode is enabled, both are recalled, regardless of whether you press [Main] or [Sub].

Image Processing

Combining the background image and input signal

Use the following procedure.

- 1** In the Frame Memory menu, select VF2 'Edit' and HF2 'Composite.'
The Composite menu appears.
- 2** In the status area, select the FM to be assigned. (*See page 351.*)
- 3** To select V/K mode, press [V/K Mode], turning it on.



- 4** Press [Edit Enable], turning it on.

This enables the combining of the background signal (the signal providing the background for combination) and the input signal (the signal providing the foreground for combination).

- 5** To use a color matte signal for the input signal, press [Frgd Color], turning it on.

Even when pair mode is enabled, you can make separate settings for each FM.

- 6** Turn the knobs to adjust the following parameters.

Knob	Parameter	Adjustment	Setting values
1	Luminance	Luminance	0.00 to 100.00
2	Saturation	Saturation	0.00 to 100.00
3	Hue	Hue	359.99 to 0.00

- 7** If you turned [Frgd Color] off in step **5**, if required press [Input Adjust] to display the Input Adjust menu, and make the video process (*see page 353*) and mask (*see page 354*) settings for the input signal.

Note

The input signal is lowered by one line, but when you apply a freeze, the freeze image is returned to the correct position.

- 8** To set the background signal to black, press [Bkgd Black], turning it on.

Notes

- When the background signal is originally black, [Bkgd Black] remains on.
- When the background signal is a freeze image (an image frozen, but not saved), turning [Bkgd Black] on erases the unsaved freeze image and, as a result, [Bkgd Black] remains on.

- 9** In the <Type> group, set the type of combination (*see page 358*).

- 10** In the state in which you want to freeze, press one of the following in the <Freeze> group, to write the freeze image to temporary memory.

Frame: Freeze one frame.

Field: Freeze one field.

Off: Release the freeze, and delete the recorded freeze image.

After carrying out the freeze, to return to the state immediately before the freeze, press [Undo] in the <Freeze> group.

Note

All freeze images written to temporary memory are lost when the system is powered off.

Saving a processed image

To save a processed image as a file, in the Edit>Composite menu use the following procedure.

1 Press [Store].

The keyboard window appears.

The default file name, “image###” (where ### is a three-digit number) is input.

2 In the keyboard window, enter the file name (maximum 8 characters).

3 In the keyboard window press the [Enter] button.

This saves the freeze image as a file in memory.

Selecting the way in which images are combined

To select the way in which the background image and input signal are combined (*see page 75*), use the following procedure.

1 In the <Type> group of the Edit>Composite menu, select one of the following methods of combination.

- **Pattern Key:** pattern key
 - **Ext Key:** external key
(This can only be selected when the pair mode is enabled. The signal selected on the frame memory source 2 bus is used as the key signal.)
 - **Mix:** mix
 - **NAM:** non-additive mix
- If none of the above is selected, image combination is not carried out.

2 Depending on the selection in step 1, set the following parameters.

- **When [Pattern Key] is selected**

Knob	Parameter	Adjustment	Setting values
1	Size	Size of pattern	0.00 to 100.00
2	Soft	Edge softness of pattern	0.00 to 100.00
3	Pattern	Pattern number	1 to 24 ^{a)}

a) The patterns are the same as for a standard wipe. See the appendix “Wipe Pattern List” (Volume 2).



- When [Ext Key] is selected

Knob	Parameter	Adjustment	Setting values
1	Clip	Reference level for key signal generation	-7.30 to +109.58
2	Gain	Key sensitivity	-100.00 to +100.00

- When [Mix] is selected

Knob	Parameter	Adjustment	Setting values
1	Mix Rate	Mix proportion	0.00 to 100.00

3 When you selected a pattern key, press [Pattern Adjust].

The Pattern Adjust menu appears. In the menu, set the pattern modifiers as required.

- When turning [Position] on and setting the pattern position

Knob	Parameter	Adjustment	Setting values
1	Position H	Horizontal position	-200.00 to +200.00 ^{a)}
2	Position V	Vertical position	-200.00 to +200.00 ^{a)}

a) See page 61.

- When turning [Multi] on and replicating the pattern

Knob	Parameter	Adjustment	Setting values
1	H Multi	Number of repetitions of pattern horizontally	1 to 63
2	V Multi	Number of repetitions of pattern vertically	1 to 63
3	Invert Type	Replication layout	1 to 4 ^{a)}

a) See page 64.

- When turning [Aspect] on and setting the aspect ratio of the pattern

Knob	Parameter	Adjustment	Setting values
1	Aspect	Aspect ratio	-100.00 to +100.00 ^{a)}

a) See page 63.

- When turning [Rotation Angle] on and inclining the pattern

Knob	Parameter	Adjustment	Setting values
1	Angle	Angle of pattern rotation	-100.00 to +100.00 ^{a)}

a) See page 61.

To select the pattern, display the Pattern Select menu by pressing [Pattern Select] button in the Pattern Adjust menu. You can change the pattern selected in step **2** here. After selecting one of the patterns (standard wipe patterns 1 to 24) displayed in the Pattern Select menu, you can adjust the following parameters.

Knob	Parameter	Adjustment	Setting values
1	Size	Pattern size	0.00 to 100.00
2	Soft	Edge softness	0.00 to 100.00

- 4** When you selected a pattern key or external key, if required press [Key Invert] in the Edit>Composite menu to invert the key.

Image Output

There are two functions related to image output: the reposition function for moving the output image, and the lock function for fixing the output image.

For an overview of the image output, see page 75.

Moving the output image (reposition function)

Use the following procedure.

- 1** In the Frame Memory menu, select VF3 'Reposition/Lock' and HF1 'Reposition.'

The Reposition menu appears. In this menu, you can also enable the V/K mode (*see page 352*).

- 2** In the status area, select the FM output. (*See page 351*.)
- 3** In the <Reposition> group, select the movement mode (*see page 75*).

Normal: Move in normal mode.

Black&White: Move in black & white mode.



- 4** With the knobs, adjust the parameters to move the image.

Knob	Parameter	Adjustment	Setting values
1	Position H	Move in horizontal direction	-200.00 to +200.00 ^{a)}
2	Position V	Move in vertical direction	-200.00 to +200.00 ^{a)}

a) See page 61.

The surroundings of the moved image on the screen are filled with black.

- 5** To return the image moved by the reposition function to the center position, in the <Reposition> group press [Center].

Note

It is not possible to write the image moved by the reposition function directly to frame memory.

Fixing the output image selection (lock function)

Use the following procedure.

- 1** In the Frame Memory menu, select VF3 'Reposition/Lock' and HF2 'Lock.'

The Lock menu appears.

- 2** In the status area, select the FM output. (*See page 351.*)

- 3** Press [Lock], turning it on.

This fixes the currently selected frame memory output image.
To release the lock, set [Lock] to off.

Image Data Management

You can carry out the following operations on the files in which images are saved.

- Delete
- Rename
- Restore

For an overview of file management, see page 76.

Deleting Files

Deleting files using the thumbnail display

Use the following procedure.

- 1** In the Frame Memory menu, select VF4 'File' and HF1 'Delete Thumbnail.'

The File>Delete Thumbnail menu appears. In the status area, whether pair mode is on or off, all of the saved files appear as thumbnails.

- 2** Using the arrow keys or turning the knob, scroll the thumbnail display.

Knob	Parameter	Adjustment	Setting values
1	Scroll	Thumbnail display scrolling	1 to ...

- 3** Press the thumbnail of the file you want to delete, to select it. To select all of the files, press [Select All], turning it on.
To deselect, press once again.

- 4** Press [Delete].

A message for confirming the deletion appears.

- 5** To confirm the deletion press [Yes], and to cancel press [No].

Deleting files using the list display

Use the following procedure.

- 1** In the Frame Memory menu, select VF4 'File' and HF2 'Delete List.'

The Delete List menu appears. In the status area, whether pair mode is on or off, all of the saved files appear in a list.

- Using any of the following methods, select the file to be deleted.
 - Press directly on the list in the status area.
 - Press the arrow keys to scroll the reverse video cursor.
 - Turn the knob to make the selection.

Knob	Parameter	Adjustment	Setting values
1	No	Memory file selection	1 to ...

To select all of the files for deletion, press [Select All], turning it on.

- To delete the main file in the selected list, press [Main] in the <Select> group. Similarly, to delete the sub file, press [Sub].
- Press [Delete].

A message for confirming the deletion appears.
- To confirm the deletion press [Yes], and to cancel press [No].

Renaming Files

Renaming a file using the thumbnails

Use the following procedure.

- In the Frame Memory menu, select VF4 'File' and HF3 'Rename Thumbnail.'

The Rename Thumbnail menu appears. In the status area, whether pair mode is on or off, all of the saved files appear as thumbnails.

- Using the arrow keys or turning the knob, scroll the thumbnail display.

Knob	Parameter	Adjustment	Setting values
1	Scroll	Thumbnail display scrolling	1 to ...

- Press the thumbnail of the file you want to rename, to select it.

When pair mode is enabled, pressing either of main and sub

simultaneously selects both files.
To deselect, press once again.

4 Press [Rename].

A keyboard window appears.

5 Enter the new name, then press the [Enter] button in the keyboard window.

This renames the file.

Renaming files using the list display

Use the following procedure.

1 In the Frame Memory menu, select VF4 'File' and HF4 'Rename List.'

The Rename List menu appears. In the status area, whether pair mode is on or off, all of the saved files appear in a list.

2 Using any of the following methods, select the file to be renamed. The main and sub files scroll simultaneously.

- Press directly on the list in the status area.
- Press the arrow keys to scroll the reverse video cursor.
- Turn the knob to make the selection.

Knob	Parameter	Adjustment	Setting values
1	No	Memory file selection	1 to ...

3 Press [Rename].

The keyboard window appears.

4 Enter the new name, then press the [Enter] button in the keyboard window.

This renames the file.

Restoring Files

Restoring a file that has been deleted

To restore a still image file in memory that has been deleted, for example by turning the power off, use the following procedure.

1 In the Frame Memory menu, select VF4 'File' and HF5 'Restore.'

The Restore menu appears.

2 Press [Restore].

This restores the file.





Chapter 8 Color Backgrounds

Color Background Setting Operations	368
Color Background Settings Menu	368
Basic Color Background Setting Operations	368

Color Background Setting Operations

You carry out color background settings in the Color Bkgd menu. This section describes the settings menu for color background 1 as an example.

For an overview of the color background, see page 78.

Color Background Settings Menu

Accessing the Color Bkgd1 menu

Use either of the following operations.

- In the menu control block, select the top menu selection button [COLOR BKGD], and press VF1 'Color Bkgd1.'
- Press a cross-point button assigned to color background 1 twice in rapid succession.

The above operation displays the Color Bkgd1 menu.

Basic Color Background Setting Operations

Making a single-color matte (Flat Color)

If you are not using the "color mix" function to combine two colors, use the following procedure.

- 1** In the <Matte> group of the Color Bkgd 1 menu, press [Flat Color], turning it on.

You can now adjust color 1.

- 2** Set the following parameters.

Knob	Parameter	Adjustment	Setting values
1	Luminance	Luminance	0.00 to 100.00
2	Saturation	Saturation	0.00 to 100.00
3	Hue	Hue	359.99 to 0.00

Making a color combination (color mix)

To combine color 1 and color 2, use the following procedure.

- 1 In the <Matte> group of the Color Bkgd1 menu, press [Mix Color], turning it on.
- 2 Set the following parameters as required.

Knob	Parameter	Adjustment	Setting values
1	Size	Pattern size	0.00 to 100.00
2	Soft	Degree of softening of edge	0.00 to 100.00
5	Pattern	Pattern number	1 to 24 ^{a)}

a) The patterns are the same as for a standard wipe. See the appendix “Wipe Pattern List” (Volume 2).

You can also carry out the pattern selection by pressing the [Mix Ptn Select] button, to display the Mix Ptn Select menu. Select any pattern appearing in the Mix Ptn Select menu (standard wipe patterns 1 to 24), and you can then adjust the following parameters.

Knob	Parameter	Adjustment	Setting values
1	Size	Pattern size	0.00 to 100.00
2	Soft	Edge softness	0.00 to 100.00

- 3 To adjust color 1, set [Color1] on, and to adjust color 2 set [Color2] on, then adjust the parameters.

Knob	Parameter	Adjustment	Setting values
1	Luminance	Luminance	0.00 to 100.00
2	Saturation	Saturation	0.00 to 100.00
3	Hue	Hue	359.99 to 0.00

- 4 If required, set the pattern modifiers.

- **When turning [Position] on and setting the pattern position**

Knob	Parameter	Adjustment	Setting values
1	Position H	Horizontal position	-200.00 to +200.00 ^{a)}
2	Position V	Vertical position	-200.00 to +200.00 ^{a)}

a) See page 61.

- **When turning [Multi] on and using replications of the same pattern**

Knob	Parameter	Adjustment	Setting values
1	H Multi	Number of repetitions of pattern horizontally	1 to 63

Knob	Parameter	Adjustment	Setting values
2	V Multi	Number of repetitions of pattern vertically	1 to 63
3	Invert Type	Replication layout	1 to 4 ^{a)}

a) See page 64.

• **When turning [Aspect] on and setting the aspect ratio of the pattern**

Knob	Parameter	Adjustment	Setting values
1	Aspect	Aspect ratio	-100.00 to +100.00 ^{a)}

a) See page 63.

• **When turning [Angle] on in the <Rotation> group and slanting the pattern**

Knob	Parameter	Adjustment	Setting values
1	Angle	Angle of pattern rotation	-100.00 to +100.00 ^{a)}

a) See page 61.

• **When turning [Speed] on in the <Rotation> group and rotating the pattern at a constant rate**

Knob	Parameter	Adjustment	Setting values
1	Speed	Rotation rate of pattern	-100.00 to +100.00 ^{a)}

a) See page 62.

• **When selecting H (horizontal) or V (vertical) in the <Modulation> group and applying waviness to the pattern**
(The modulation is always a sine wave.)

Knob	Parameter	Adjustment	Setting values
1	Amplitude	Amplitude of modulation	0.00 to 100.00
2	Frequency	Frequency of modulation	0.00 to 100.00
3	Speed	Speed of waves	-100.00 to +100.00 ^{a)}

a) See page 65.

- 5** To interchange color 1 and color 2, press the [Color Invert] button, turning it on.



Chapter 9 Copy and Swap

Basic Copy and Swap Operations	372
Copy and Swap Menu Operations	372
Copy by Button Operation.....	373

Basic Copy and Swap Operations

Copy and Swap Menu Operations

There are two ways of carrying out a copy operation: by using the menus or by a simple button operation. Swap operations, and operations on DME data can only be done with a menu operation.

Accessing the Copy/Swap menu

In the menu operation section top menu selection buttons, press the [Copy/Swap] button. The Copy/Swap menu appears.

Here a copy/swap operation on wipe data is described by way of example, using the Copy/Swap>Wipe menu, but the same general procedure applies to all of the following menus.

- M/E: Copying and swapping M/E data
- Key: Copying and swapping key data
- Wipe: Copying and swapping wipe data
- DME Wipe: Copying and swapping DME wipe data
- Matte: Copying and swapping matte data
- Color: Copying and swapping color data
- DME: Copying and swapping data by DME channels

For an overview of the concepts involved, see “Copy and Swap” (page 79).

Note

To use DME requires the BKDS-9470 DME Board Set.

Copying and swapping wipe data

As an example, to copy or swap wipe data, use the following procedure.

- 1** In the Copy/Swap menu, select HF3 ‘Wipe.’

The Copy/Swap>Wipe menu appears.

The status area shows lists for the copy/swap source on the left, and the copy/swap destination on the right.

- 2** In the <Data Select> group, select any of the following.

Wipe: The operation applies to wipes in the transition control block.

Key Wipe: The operation applies to wipes in the independent key transition control block.

3 Using any of the following methods, select the data to be copied or swapped.

- Press directly on the list appearing in the status area.
- Press the arrow keys to scroll the reverse video cursor.
- Turn the knobs to make the setting.

Knob	Parameter	Adjustment	Setting values
1	Left No	Select data for copy/swap source	1 to 4 ^{a)} 1 to 16 ^{b)}
2	Right No	Select data for copy/swap destination	1 to 4 ^{a)} 1 to 16 ^{b)}

- a) Transition control block wipe data
- b) Independent key transition control block wipe data

For details of the data affected, see “Copy and Swap” (page 79).

4 To copy, press [Copy], and to swap, press [Swap].

This carries out the copy or swap.

To undo a copy or swap

Press [Undo], to return to the state before the copy or swap was carried out.

Copy by Button Operation

You can carry out the following copy operations by a simple button operation.

- M/E copy
- Keyer copy
- Wipe copy
- DME wipe copy

For an overview of the copy function, see “Copy and Swap” (page 79).

Basic button operation

The basic button operation is to hold down the copy source button, then press the destination button.

You can undo the last operation using [Undo] in the menu (*see page 373*).

M/E copy button operation

In the Flexi Pad control block of each M/E bank, use the [SNAPSHOT] button.



To copy from M/E-1 to M/E-2

In the M/E-1 Flexi Pad control block, hold down the [SNAPSHOT] button, then press the [SNAPSHOT] button in the M/E-2 Flexi Pad control block.

Keyer copy button operation

To specify the copy source, use the key delegation buttons in the key control block, and to specify the copy destination, use the key delegation buttons in the independent key transition control block.

To copy from M/E-1 key 1 to M/E-2 key 2

In the key control block M/E delegation buttons, press [M/E1], turning it on, then hold down the [KEY1] button, and in the M/E-2 independent key transition control block, press the [KEY2] button.

Wipe copy button operation

Use the [WIPE] button in the Flexi Pad control block of each M/E bank.

To copy the M/E-1 wipe to the M/E-2 wipe

In the M/E-1 Flexi Pad control block, hold down the [WIPE] button, then press the [WIPE] button in the M/E-2 Flexi Pad control block.

DME wipe copy button operation

Use the [DME] button in the Flexi Pad control block of each M/E bank.

To copy the M/E-1 DME wipe to the M/E-2 DME wipe

In the M/E-1 Flexi Pad control block, hold down the [DME] button, then press the [DME] button in the M/E-2 Flexi Pad control block.

Chapter 10 Misc Menu, Etc.

Misc Menu Operations	376
AUX Menu Operations.....	378
AUX Bus Settings	378
Video Process Settings.....	379

Misc Menu Operations

In the Misc menu, you can carry out the following operations.

- Enable (on) or disable (off) control from external devices for each port of the switcher and DME.
- Switch the safe title function on or off for each output.

Enabling or disabling control from an external device

Use the following procedure.

- 1** In the menu control block, press the top menu selection button [Misc], then select VF1 ‘Enable’ and HF1 ‘Port Enable.’

The Misc>Enable>Port Enable menu appears with the status area showing the settings of the following ports.

- Switcher Remote 1 to Remote 4 ports (RS-422A, D-sub 9-pin)
- Switcher GPI port (parallel, 25-pin)
- DME1/DME2 Editor ports (RS-422A, D-sub 9-pin)
- DME1/DME2 GPI ports (parallel, 25-pin)

- 2** In the <Switcher> or <DME> group, press on the name of the port for which you want to disable control from an external device, turning it off. To re-enable control for the port, press on its name once more.

Notes

- It is not necessary to make any settings for DME2.
- For the AUX bus operation from the Remote1 to Remote4 ports of the switcher, the setting (Enable/Disable/Manual) in the Setup menu takes precedence. Only when the setting is “Manual,” the settings made in the Port Enable menu apply. *For details, see “Interfacing With External Devices (Device Interface Menu)” under “Setup Relating to Switcher Processor” in Chapter 16 (Volume 2).*

Switching the safe title function on or off

Use the following procedure.

- 1** In the menu control block, press the top menu selection button [Misc] and select VF2 ‘Safe Title.’

The Misc>Safe Title menu appears.

2 Using any of the following methods, select the signal to which the settings apply.

- Directly press the list in the status area.
- Press the arrow keys to scroll the reverse video cursor.
- Turn the knob to make the setting.

Knob	Parameter	Adjustment	Setting values
1	Output	Signal to which the settings apply	1 to 48

Note

It is not possible to change the setting for the output for which the safe title is set off in the Setup menu. (See “Making safe title settings” in Chapter 16 (Volume 2).)

3 Press [Safe Title] to set it on or off.



AUX Menu Operations

AUX Bus Settings

Making video process settings for an AUX bus

Make the settings as follows.

- 1 In the Aux/Mon>Aux Bus menu, using any of the following methods, select the AUX bus to which the settings apply.
 - Directly press the list in the status area.
 - Press the arrow keys to scroll the reverse video cursor.
 - Turn the knob to make the setting.

Knob	Parameter	Adjustment	Setting values
6	AUX Bus	AUX bus selection	1 to 48

- 2 Press [Video Process], turning it on.
- 3 Adjust the following parameters.

Knob	Parameter	Adjustment	Setting values
1	Video Gain	Video signal gain	-200.00 to +200.00
2	Y Gain	Luminance signal gain	-200.00 to +200.00
3	C Gain	Chrominance signal gain	-200.00 to +200.00
4	Hue Delay	Hue delay	-180.00 to +180.00
5	Black Level	Black level	-7.30 to +109.58

To return adjustment values to their defaults

Press [Unity].

Video Process Settings

This section describes operations on the M/E-1 to M/E-3, and PGM/PST background A and B buses, and utility buses 1 and 2.

For these operations, use the Misc>Video Process menu in the respective operating bank.

For video process settings on other buses, see the following.

- *Settings for a particular input signal: “Signal input settings” in Chapter 16 (Volume 2)*
- *Key fill bus settings: “Video Processing” (page 286)*
- *Settings for frame memory source buses 1 and 2: “Setting video processing” (page 353)*
- *Settings for Aux 1 to 48 buses: “Making video process settings for an AUX bus” (page 378)*
- *Overview of video process: “Video Process” (page 83)*

This section describes an example on the background A bus of the M/E-1 bank. For the background B bus or utility bus 1 or 2, make the adjustment with a similar procedure.

Making video process settings for each bus

Use the following procedure.

- 1** In the menu control block, press the top menu selection button [M/E1] and select VF7 ‘Misc’ and HF2 ‘Video Process.’
- 2** In the <Bkgd-A> group, press [Video Process], turning it on.
- 3** Adjust the following parameters.

Knob	Parameter	Adjustment	Setting values
1	Video Gain	Video signal gain	-200.00 to +200.00
2	Y Gain	Luminance signal gain	-200.00 to +200.00
3	C Gain	Chrominance signal gain	-200.00 to +200.00
4	Hue Delay	Hue delay	-180.00 to +180.00
5	Black Level	Black level	-7.30 to +109.58

To return the parameter settings to the defaults

Press [Unity] in the <Bkgd-A> group.



Index

A

- Additive mix 47
- Alarm 151
- Angle 61
- Aspect ratio 63, 317, 326
- Attributes 141
- Auto
 - chroma key adjustments 266
 - transition 42, 141, 243
- AUTO button 193
- AUTO DELEG button 182
- AUTO INS button 190
- AUTO TRANS button 174, 176, 208
- Auto/manual transition combination 244
- AUX
 - bus settings 150, 378
 - delegation buttons 194
 - menu operations 378
- Auxiliary bus control block 194
- Axis location 92

B

- Background 111
 - A/B row 170
 - changing 32
 - mask 53
- Bank selection buttons 199
- Basic menu operations 210
- Beveled edge 99
- Blind 104
- Blink 54
 - function 285
- Blur 99
- Border 51, 98
 - parameters 291
- Brick 116
- Brightness adjustments 151

- Broken glass 103
- BS button 220
- Bus fixed mode 43
 - fader operation 245
 - wipe direction 246
- Bus selection 26
- Button
 - assignment settings 150
 - numbers 29, 30

C

- Caps Lock button 220
- Channel ID 95
- Character trail 109
- Chroma key 47
 - adjustments 266
 - composition 265
 - shadow 49
 - shadow adjustment 270
 - window 48
- Circle 106
- Clean mode 47
- Clear button 219, 221
- Close button 218, 220
- Color
 - combination 78, 368
 - matte settings 234
 - vector key 46
- Color background 78
 - selection 78
 - setting operations 368
 - settings menu 368
- Color cancel 48
 - adjustments 267
- Color data
 - copy 81
 - swap 81
- Color mix 78, 368
 - for edge fill matte 313
 - for key fill 272
- Combiner 113
- Contrast 100

- Control panel 164
 - configuration 1 164
 - configuration 2 166
 - configuration 3 168
- Coordinate axes 95
- Copy 79, 372
- Crop 98
- Cross-point
 - button numbers 170
 - button settings 149
 - buttons 169
 - control block 169
 - hold 141
- Custom mode 146
- Cut 42
- CUT button 175, 208
- Cylinder 107

D

- Dead zone 345
- Defocus 98
- Del button 221
- Delay setting 132
- Delegation buttons 179
- DEST button 195
- Detents 89
- Device
 - Interface 154
 - management 147
- DEVICE connectors 198
- Device control block
 - joystick 187
 - trackball 183
- Digital multi effects 85
- Direction 59, 310, 323, 334
- Disk recorder control 121
- Display 181, 192
- DME 85, 174, 176, 208
 - applying to a key 283, 296
 - channel selection buttons 181

- setup 154
- special effects 97
- DME channel
 - copy 82
 - swap 82
- DME patterns
 - user programmable 342
- DME wipe pattern 68
 - edge modification 334
 - groups 68
 - selection 332
- DME wipe settings 332
 - for independent key transitions 339
- DME wipes 68, 331
 - copy 80, 81
 - direction 334
 - modifiers 333
 - position 335, 340
 - snapshot 71, 341
 - swap 80, 81
- Downstream key control block 205
- Drop border 51
 - parameters 292
- Duration
 - effect 130
 - keyframe 130
 - modes 129
 - setting buttons 189
- Dust mix 58, 309

E

- Edge 60
 - fill 53
 - modifiers 50
- EDIT ENBL button 188
- Edit point specification buttons 188
- Editing buttons 189
- EFF LOOP button 190
- Effect 127
 - attributes 128
 - dissolve 128, 141
 - duration 130
 - editing 128
 - execution 138

- saving/recalling 128
- Effect execution direction selection buttons 190
- Emboss 52
- Enter button 219, 221
- Explosion 108
- External
 - key 75
 - processed key 297
- External devices 118
 - connections 150
 - disk recorder control 121
 - GPI device control 120
 - P-BUS device control 119
 - shared control functions 118
 - VTR control 121

F

- Fade to black 44, 253
 - control block 193
 - transition rate 253
- Fader lever 174, 206, 208
- Files 158
 - operations 158
- Flag 102
- Flexi Pad control block
 - simple type 200
 - standard type 177
- Flip-flop mode 43
- Flying bar 103
- Frame input mode 236
- Frame memory
 - feed 285, 297
 - overview 73
 - settings 153
- Frame memory operations 348
 - capturing an image 352
 - input image selection 350
 - menu display 348
 - preparations 348
 - selecting frame memory 351
 - selecting outputs 351
- Freeze 74, 100, 352
- Fringe 65

- FTB button 193
- FULL LINK 59
- Function
 - button area 216
 - selection buttons 192

G

- Global
 - coordinate space 86
 - effects 112
- GPI Device control 120
- GPI output 141
- Graphics display 95
- Grid 96

H

- HF buttons 216

I

- Image
 - capturing 74
 - data management 76, 362
 - data transfer 76
 - output 75
 - processing 75
 - recalling 75
 - saving 75
- Image file
 - deletion 362
 - renaming 363
- Independent key transition 35, 248
 - DME wipe settings 339
 - simple transitions 258
 - type 249
 - type selection buttons 176, 203, 205
 - wipe modifiers 323
 - wipe settings 322
- Independent key transition control block
 - simple type 203
 - standard type 248
- Independent key transition execution section 176, 203, 206, 209

Independent key transition rate
250
display 252
setting by a menu operation 251
setting in the Flexi Pad
control block 250
setting in the numeric key-
pad control block 250

Input
signal settings 152, 154
string 220
value 218

Installation 147
Interpolation 111
Invert 111
Item display 218, 220

J

Joystick 187

K

Kaleidoscope 105
Key 46
1/2 row 169
bus selection buttons 171
control block 179
default 55
delegation buttons 176,
205
deleting 33
density adjustment 112
disable 141
edge modifications 273,
291
inserting 33
mask 53
memory 54
modifier buttons 180
modifiers 50
modify clear 55
output destination 284
output status display 230,
257
settings 153
signal adjustments 268

source selection 112
status display 175, 202,
209
Key active 48
adjustment 267
KEY button 195
Key fill
selection 271
selection buttons 180
Key priority 227
display 230, 257
selecting 34
setting by a menu operation 229
setting in the transition
control block 227
Key setting
using menus 262
Key snapshot 299
buttons 176, 206
recalling 300, 302
saving 299, 301
setting buttons 176, 206
using simple transition
module 301
Key source
name display 176, 206
selection 271
selection buttons 180
Key transition
selection buttons 201
Key type
selection buttons 180
setting 263
Keyboard window 220
Keyer
copy 80
swap 80
Keyframe 127
control block 188
duration 130
effect registers 125
status 216
strobe 110
KF button 176
Knob 181, 197
parameter buttons 216
K-SS button 204

L

Left button 221
Lens 106
Level selection buttons 196
Lighting 109
Line feed button 221
Linear key 46
Local coordinate space 86
Location
size 93
XYZ 91
Lock function 361
Luminance key 46

M

M/E
bank display 172
copy 79
swap 79
Macros 160
attachment 161
editing 161
events 160
execution 161
pause events 161
registers 160
Magnitude 62
Main mask 53
using 280, 295
Main/sub modifier link 59
Maintenance 147
Manual transition 43, 243
Masks 53, 279, 295
Master
region 125
snapshot registers 126
timeline registers 126
timelines 139
Matte data
copy 81
swap 81
Max./min. value indication
218
Melt 109
Memory
card slot 198
initialization 147

recall buttons 199
Memory card/USB adaptor block 198
Menu
 accessing 210, 215
 control block 197
 display 197
 operations 217
 organization 210
 page number button 216
 screen 216
 title button 216
MENU button 186
Minus button 219
Mirror 105
Misc menu operations 376
MIX 75, 174, 176, 208
Mix 39, 57
Mode selection buttons 177, 191, 202
Modulation 65, 319
Mono 99
MORE button 181
Morphing 57
Mosaic 100
 glass 101
Motion decay 110
Multi 63, 317, 326
 mirror 105
 move 99

N
NAM 40, 75, 174, 208
Nega 100
Negative NAM 57
Network configuration 145
Next transition 32
 selecting 32
 selection buttons 174, 207
Non-additive mix 40, 174, 208
Nonlinear effects 101
Non-Sync state 244
Normal
 edge 294
 mix 47
Numeric display 178, 202

Numeric keypad 192
 control block 191
 window 218

O

ON AIR indicators 181
One-stroke mode 40
One-time mode 40
Operation
 buttons 184
 modes 74
 settings 150
Outline 52
 parameters 293
Output
 destination specification
 buttons 182
 signal settings 153
OVERRIDE button 182

P

Page turn 107
Pair mode 73
Pairing 64, 318
Panel setup 149
Panorama 106
Parameter group button 216
Paths 133
 DME 134
 switcher 133
 types 137
Pattern key 75
Pattern limit 44, 239
 buttons 175, 201
 setting by a menu operation 240
 setting with the fader lever 240
 transition 241
Pattern mix 57, 307
 types 57
Pattern replication 63
Pause events 161
P-BUS devices 118
 control 119
Perspective 94

Plane function 48
Positioner 61, 315, 323, 335, 340
Positive NAM 57
Posterization 100
Preset color mix 40
Preview 44, 247
 selection buttons 193
Previous page button 216
PRIOR SET button 175, 209
PST COLOR MIX 174, 208

R

Reentry buttons 26, 170
Reference region 124
Regions 124
 selection buttons 191
Registers 125
Related manuals 21
Replication 326
Resume mode 146
Right button 221
Rings 103
Ripple 102
Roll 107
Rotation 61, 91, 316, 325
Router interface setup 155
RTR button 196

S

Screen saver 151
Second (2ND) button 195
Selected
 bus display 195
 source name displays 195
SEMI LINK 59
Separate sides 111
Sepia 99
Setup 145
 DCU input/output 155
 overview 145
 panel 149
 router interface 155
 switcher 151
 system 145

Setup data saving/recalling 148
Shadow 51, 116
 parameters 292
SHIFT button 171
Shift button 220
Shotbox 144
SHOW KEY button 181
Show key function 298
Signal
 assignment to buttons 28
 name display 31
 selection 25
Simple
 transition 255
Skew 95
Snapshot 140
 attributes 141
 registers 126
Soft edge 52, 323
Softening
 edge 294
 wipe pattern edge 323
Solarization 100
Source
 coordinate space 85
 name displays 195
Space button 220
Speed 62
Sphere 108
Spin 92
Spiral 66, 320
Split 60, 104, 311
 fader 257
 slide 104
Spring 66, 319
Standard wipe patterns 56
Start up state 146
Status area 216
STOP NEXT KF button 190
Sub (subsidiary) mask 53, 54
 using 282, 295
SUPER MIX 174, 208
Super mix 40
 settings 233
Swap 79, 372
Swirl 108
Switcher setup 151

System
 configuration 145
 features 22
 reset 147
 setup 145

T

Tally interface setup 155
Target coordinate space 85
TC button 218
Temporary attributes 128, 142
Three-dimensional
 coordinate space 85
 parameter display 97
 parameters 87
 transformations 85
Time offset execution 37
Timecode input mode 236
Top menu selection buttons 197
TRACE button 182
Trail 110
TRANS PVW button 175, 209
Transformation operation modes 90
Transition
 auto 42
 execution 42, 235
 indicator 206
 manual 43
 next 32
 operating procedure 224
 preview 44, 247
Transition control block
 compact type 207
 simple type 200
 standard type 173
Transition execution
 section 174, 201, 208
 with the fader lever 243
Transition indicator 174, 208
 function 235
Transition rate 236
 display 174, 208

 setting by a menu operation 239
 setting in the Flexi Pad control block 237
 setting in the numeric keypad control block 238

Transition type 39
 selecting by a menu operation 232
 selection buttons 174, 201, 208
Trim button 219
Twist 102

U

UNDO button 178, 202
User preference button 197
User programmable DME
 Notes on keyframe creation 343
 patterns 342
 transition mode 342
USER regions 124
UTIL button 171
Utility 143
Utility/shotbox control block 199

V

V/K mode 74
VF buttons 216
Video
 processing 24, 286
 signal adjustment 49
 switching 153
Video process 83
 memory 84
 settings 379
VTR control 121

W

Wave 101
Window adjustment 49, 269
WIPE 174, 176, 208
Wipe 41, 56
 copy 80

- enhanced 56
- mosaic 56
- position 315, 323
- random/diamond dust 56
- rotary 56
- standard 56
- swap 80
- Wipe direction 310, 323
 - selection buttons 175, 201, 208
- Wipe modifiers 309
- Wipe pattern
 - aspect ratio 317, 326
 - edge modification 311
 - key 50
 - modifiers 59
 - modulation 319
 - replication 317, 326
 - rotation 316
 - selection 304
 - types 56
 - variation 59
- Wipe pattern/modifier combinations 320
- Wipe settings 153, 304
 - for independent key transitions 322
- Wipe snapshot 67, 327
 - deleting 330
 - recalling 329
 - saving 328
- Wire frames 95

X

- XPT HOLD
 - buttons 171, 195
 - status display 202

Y

- Y balance 49
 - adjustment 269

Z

- Zabton 52, 278, 294
- Z-ring 186

The material contained in this manual consists of information that is the property of Sony Corporation and is intended solely for use by the purchasers of the equipment described in this manual.

Sony Corporation expressly prohibits the duplication of any portion of this manual or the use thereof for any purpose other than the operation or maintenance of the equipment described in this manual without the express written permission of Sony Corporation.

Sony Corporation

B & P Company

<http://www.sony.net/>

Printed on recycled paper

DVS-9000/9000SF
System (WW)
3-704-666-02 (1)

Printed in Japan
2003.02.13
©2002